

**INSTRUCTIONS
FOR USE**

DISC HARROW

"IN X-FORMATION"

TRAILED TANDEM

RANGE SXD - SX

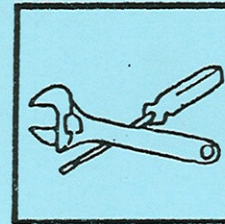

ADJUSTMENT

1997

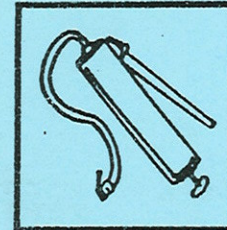

MAINTENANCE



49230 MONTIGNÉ-SUR-MOINE - FRANCE
TÉL. 02 41 64 72 67 - TÉLEX 721 241 F - FAX 02 41 64 67 73



INTRODUCTION

For the start and optimal use of your disc harrow, respect the following instructions.

These instructions must be considered an integral part of the disc harrow and handed over in case of reselling.

The left or right side of the disc harrow is determined by looking from the rear of the disc harrow towards the drawbar.

All the information, drawings and specifications indicated in these instructions are the newest at the time of publication.

We reserve the right to bring modifications at any time without previous notice.

Arbitrary modifications made on the disc harrow exclude the manufacturer's responsibility if any damage should result from these modifications.

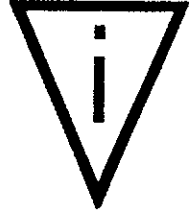

THIS SIGN IS USED THROUGHOUT THE LEAFLET TO CALL YOUR ATTENTION TO THE INSTRUCTIONS REGARDING YOUR SAFETY. RESPECT THEM AT ALL TIMES.

CAREFULLY READ THESE INSTRUCTIONS

HYDRAULIC SUPPLY SXD_SX

METRIC THREADED
HOSE D2C 5/16

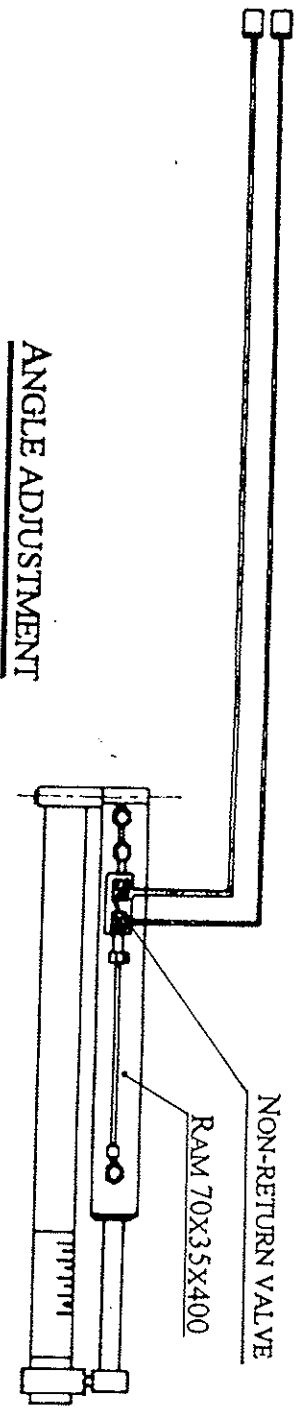
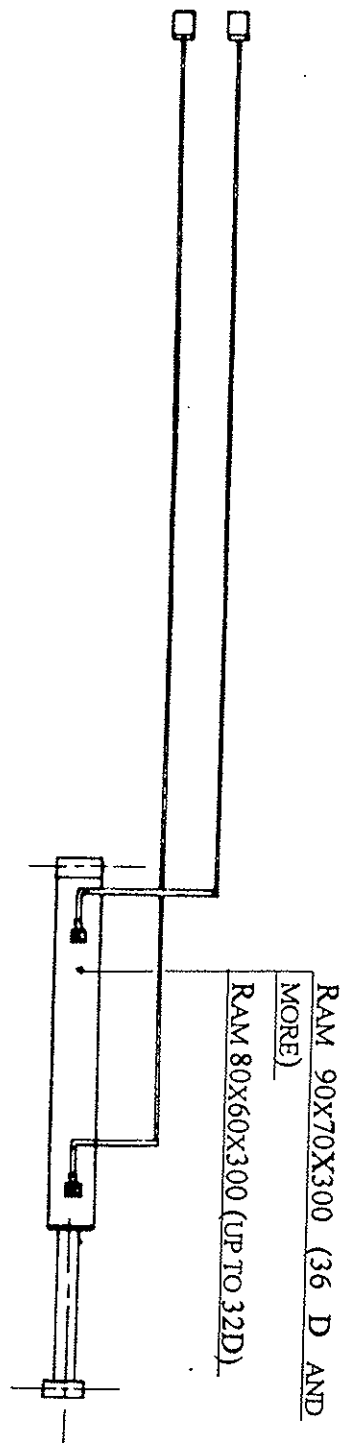

HYDRAULIC SUPPLY SXD_SX

METRIC THREADED
HOSE D2C 5/16

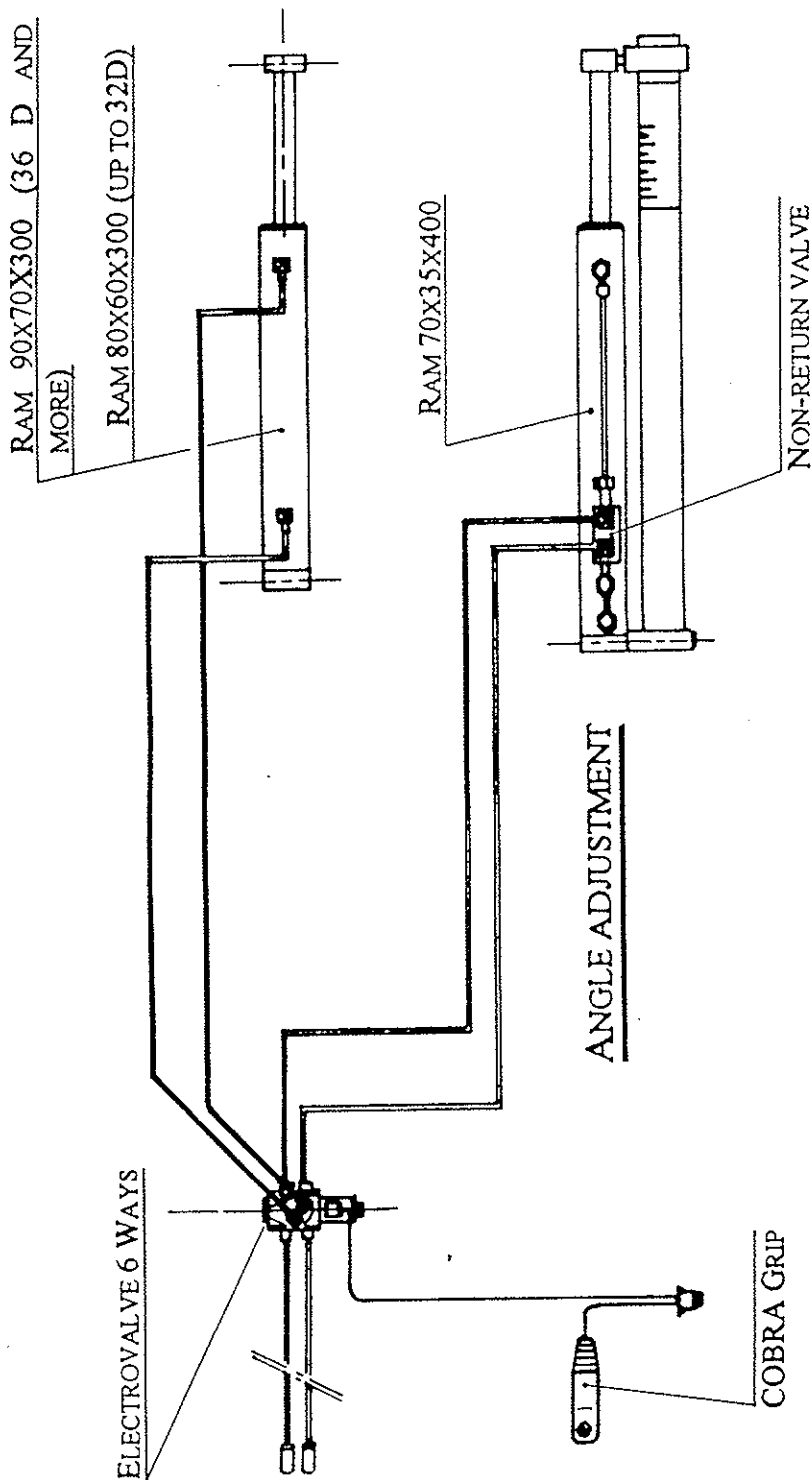

**READ THE
INSTRUCTIONS
BOOKLET**

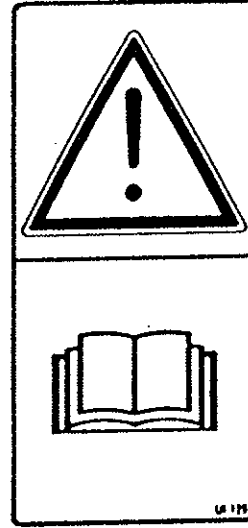

Read the instructions booklet and the safety instructions before use. Respect these instructions when using the disc harrow.

**MOVE AWAY FROM THE
MACHINE**

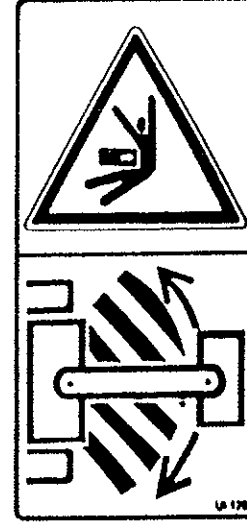

Stay in the background of the safety zone when the machine is unfolding.

THE SAFETY ZONE

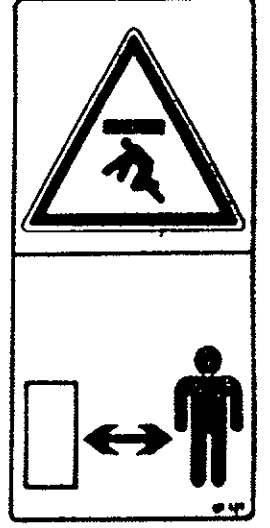

Danger in the working zone stay in the background

**LOCKING BEFORE
ACTION**



Install the locking system before any intervention on the machine.

**LEAK AND
MAINTENANCE**

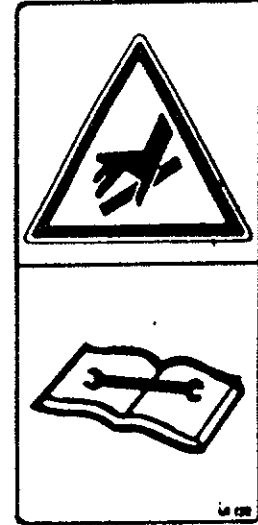

Be careful of the leaks of fluids under pressure Refer to the instructions of this booklet for the maintenance

IDENTIFICATION OF THE IMPLEMENT

(Overall View)
SXD . SX

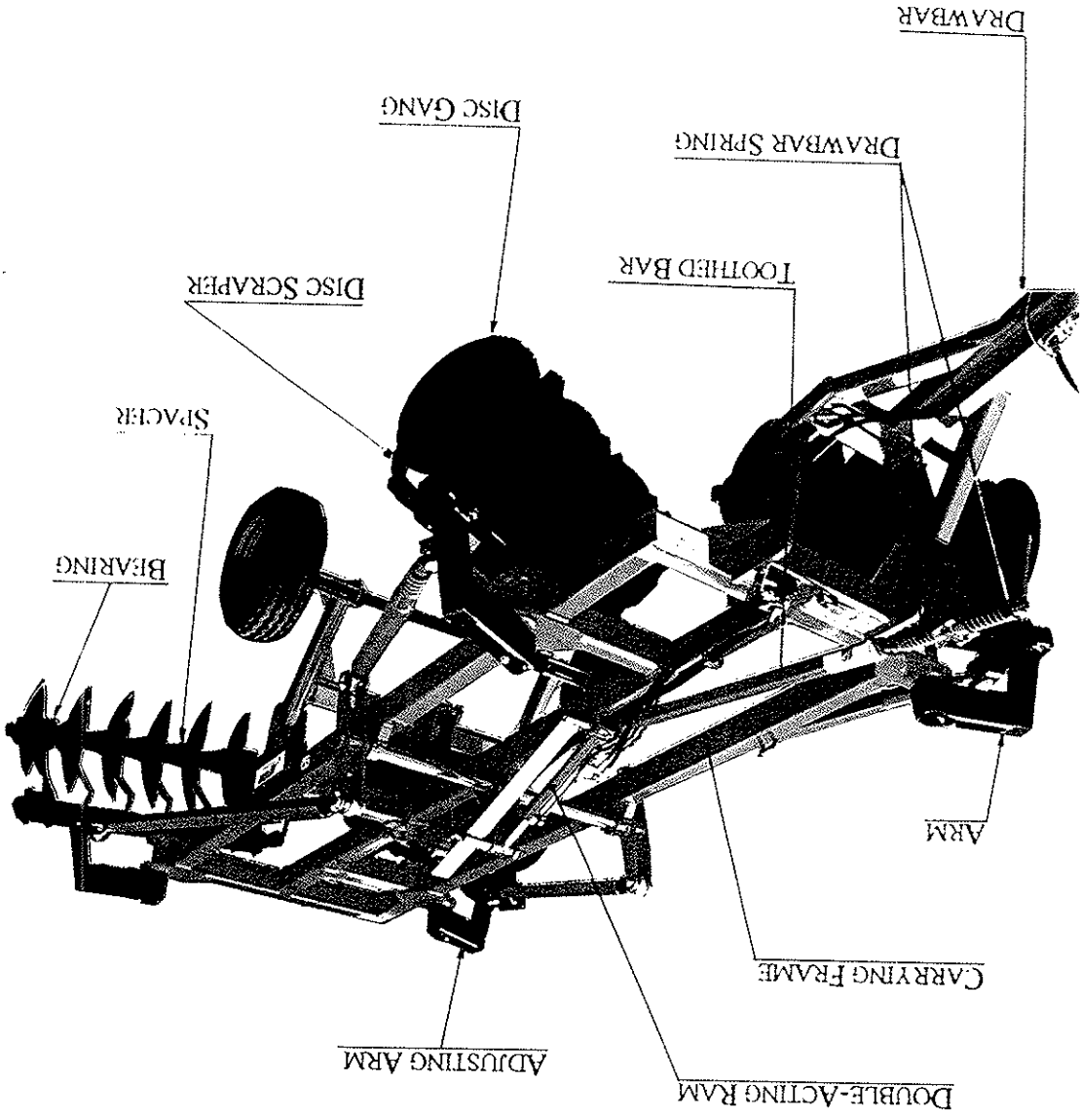

PRACTICAL ADVICE FOR ADJUSTMENT

EFFECTS	POSSIBLE CAUSES	ANSWERS
Insufficient working depth	Opening angle not large enough Wheel-train touches	Increase opening angle Lift the wheels
Work is too deep	Opening angle too large Wheel-train does not touch	Reduce opening angle Lower the wheels
Formation of a ridge during work	Bad stability of the machine. The rear discs penetrate more in the soil than the front ones.	Stabilise the machine. Increase the depth of the front discs by modifying the stop of the drawbar ram.
Formation of a hollow during work	Bad stability of the machine. The rear disc gangs penetrate less in depth of the rear discs than the front ones.	Stabilise the machine. Increase the working depth of the rear discs by modifying the stop of the drawbar ram.
Trash between discs	Scrapers badly adjusted Unfavourable working conditions	Adjust scrapers

MAINTENANCE

In case of modification on a disc gang:

Take care of the piling-up of spacers and discs (concave part in the disc hollow - convex part on the disc back). When tightening the nut at the shaft end, change the tab washer if necessary, grease the worm and the inner faces.

Tighten the nut at the end of the shaft to about 100 kg/M. Bearings of disc gangs should be greased every day according to the frequency of use (do not grease in an intensive way; a few pumps of grease are sufficient).

IMPLEMENT FOLDING

The trailed disc harrow **SXD - SX** is fitted with an hydraulic folding system. This system is comprised of a ram fed from the tractor which adjusts the angle of the disc gang by means of a connecting rod.

When the machine is in transport position, the disc gangs are positioned in the width of the frame. The machine width is smaller than 3m.

SOME SAFETY RULES ARE ESSENTIAL (see p. 4).

IMPORTANT

Before any folding of the machine, make sure that nobody is standing in the safety zone.

PRELIMINARY ADJUSTMENT

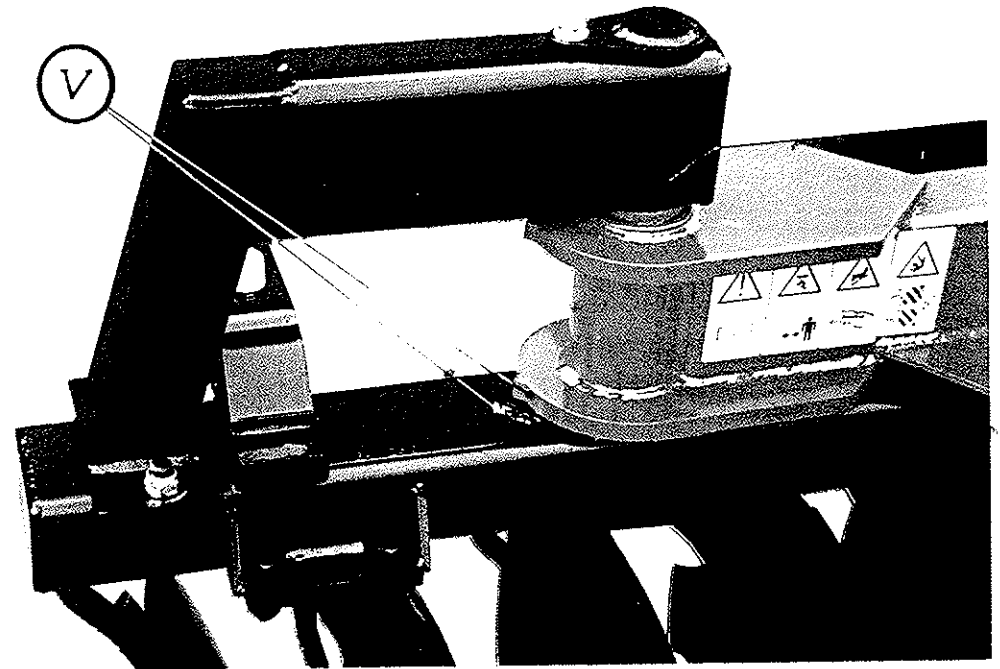

In case the machine is delivered dismantled or out of order, if necessary after remounting do the following adjustment :

- ☛ Put the lifted machine into transport position.
- ☛ Unfold hydraulically the disc gangs.
- ☛ For adjusting the disc gangs perpendicular to the frame : adjust if necessary on the 4 adjusting arms so that the both points placed on the frame and on the arm carrying the disc gangs are superposed in "V" (see the above drawing) (after adjustment tighten the lock-nuts placed on both rear folding cylinders).

SAFETY INSTRUCTIONS

ATTENTION !

Disc harrows "GREGOIRE-BESSON" are manufactured to be used only for usual agricultural work.
The operator is responsible for every use out of this context.

ADJUSTMENT

Carry out adjustment and maintenance work only when the disc harrow is not in operation.

Wear appropriate safety clothes when doing maintenance work

Ensure a safety zone for other people.

Do not carry out any adjustment and maintenance work without perfectly understanding the procedure.

For all maintenance work, use the appropriate tools and equipment.

RECOMMENDATIONS



Get used to the disc harrow functioning and disc harrow controls. Do not let anybody use the disc harrow without previous training.

Only the operator is allowed to be in the tractor cab. He must not leave the seat while working.

Nobody is allowed to climb onto the machine during work.

Before each sequence, be sure that nobody is standing in the turnover area of the disc gangs or the roller.

In case of a machine fitted with hydraulic folding, operate folding system only from the tractor cab !

WORKING DEPTH ADJUSTMENT

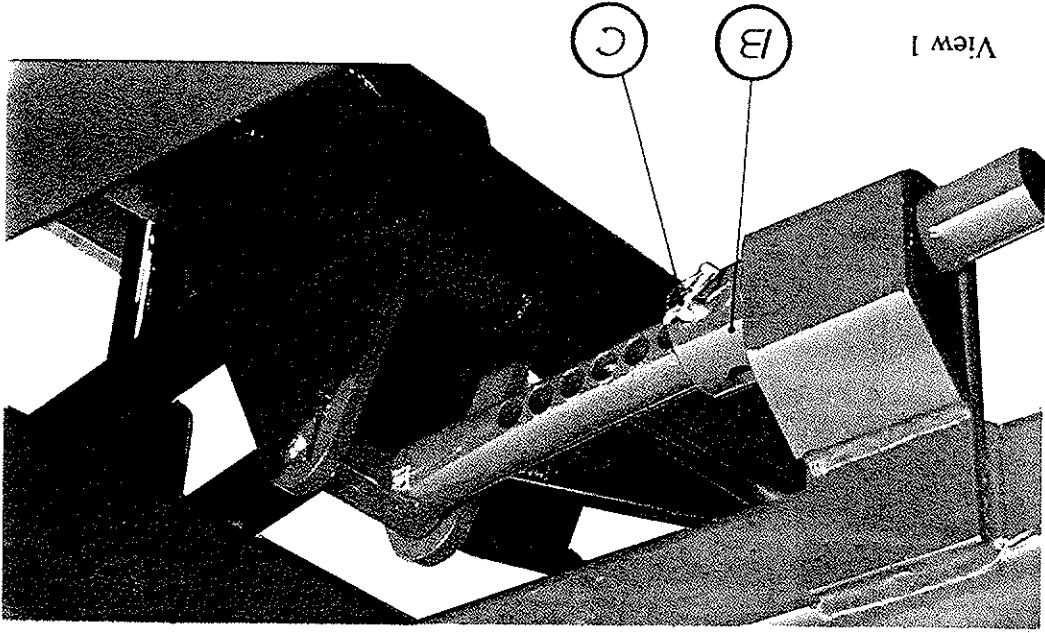

View 1

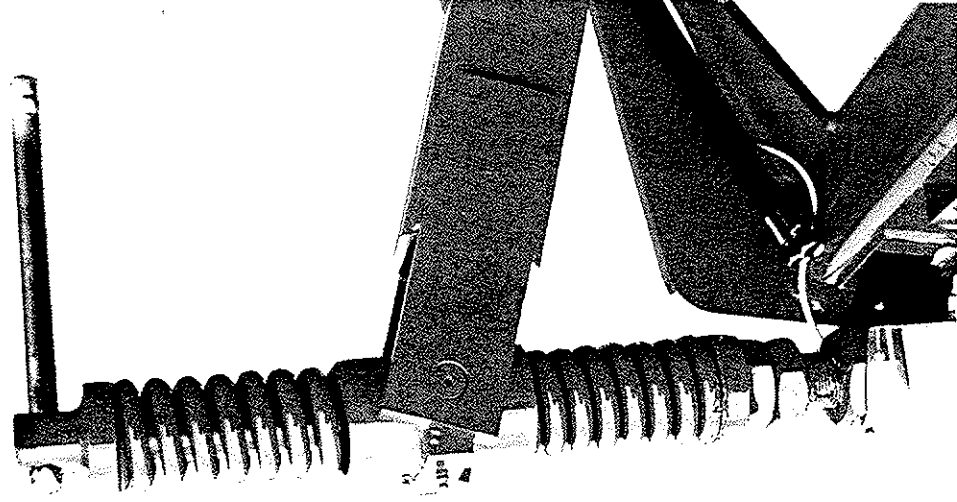

View 2

WORKING DEPTH ADJUSTMENT

For perfect work, the machine must be perfectly horizontal in comparison with the ground. The working depth of the front and rear discs must be strictly the same.

WORKING DEPTH ADJUSTMENT BY ADJUSTING THE WHEELS. (View 1):

- ☛ Put the machine into a position with discs above the ground.
- ☛ Choose a hole according to the wished depth.
- ☛ Put the pin **C** in the sliding ring **B** on the depth limiting bar (bar comprised of several adjustment holes). The ring includes 2 holes so as to have a more precise adjustment.

The both springs placed at the end of the toothed bar must be compressed in the same way during work (view 2).

MAINTENANCE

During maintenance, be sure that the safety instructions are respected.

Maintenance zone must be clean, dry and well-lit.

- ☛ In case of intervention or dismantling of a disc gang with the machine lifted, be sure to support the gangs. After intervention make sure that all the tools and equipment are out of the maintenance area.
- ☛ All the articulations must be greased at regular intervals with quality grease.
- ☛ Check regularly tightening of nuts and bolts.
- ☛ Keep a correct tyre inflation pressure. Do not exceed recommended inflation pressure.



WHEEL 10.0-75x15 (10 plis) → 5.2 bars
WHEEL 11.5-80x15.3 (10 plis) → 4.6 bars

ATTENTION !!

Explosion of the tyre with the rim can provoke serious injuries. Only experienced people are allowed to repair tyres and rims with the appropriate tools.

- ☛ Always use genuine GREGOIRE-BESSON parts; these parts only correspond to the manufacturer's technical particularities.

**THE GOOD MAINTENANCE OF YOUR MACHINE
GUARANTEES ITS LONG LIFE**

STORAGE OF THE DISC HARROW

- ☛ If the machine is unused after season, clean the disc harrow carefully to prevent from every risk of corrosion and dampness.
- ☛ If necessary, carry out paint touchings up.
- ☛ Check that there are no worn or broken parts on the disc harrow. If the case arises, order the parts and ensure maintenance work.
- ☛ Park your disc harrow under cover from bad weather.

HYDRAULIC CONNECTION

- ☛ The hydraulic connection can be subjected to high pressures.
- ☛ When the machine is fitted with several oil plugs, respect the oil flow direction of each one.
- ☛ Before assembling oil plugs, check that the pressure is a nil draw on the tractor and the disc harrow.
- ☛ If you notice hoses in bad condition, do not hesitate to change it. Respect its dimensions.
- ☛ Never search for a leak with your hand. Leaking fluids (oil) can come through the skin and provoke serious injuries.
- ☛ In case of injury, consult a doctor immediately.
- ☛ In case of an intervention on the hydraulic system, lower the machine onto the ground, stop the pressure by stopping the tractor motor and then by acting on the spool-valve.



GANG ANGLE ADJUSTMENT

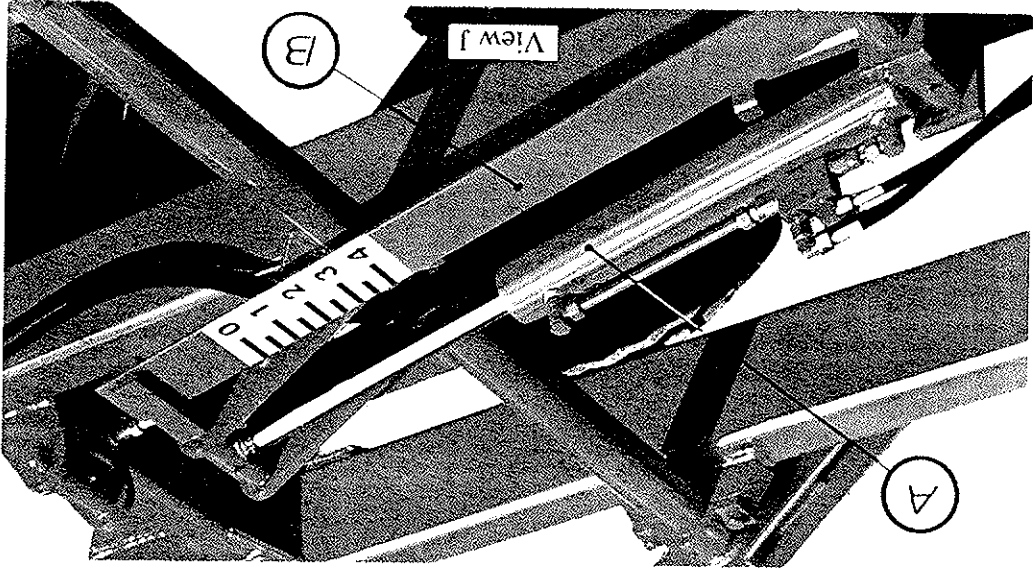

ANGLE ADJUSTMENT BY MEANS OF A GRADUATED SLIDER

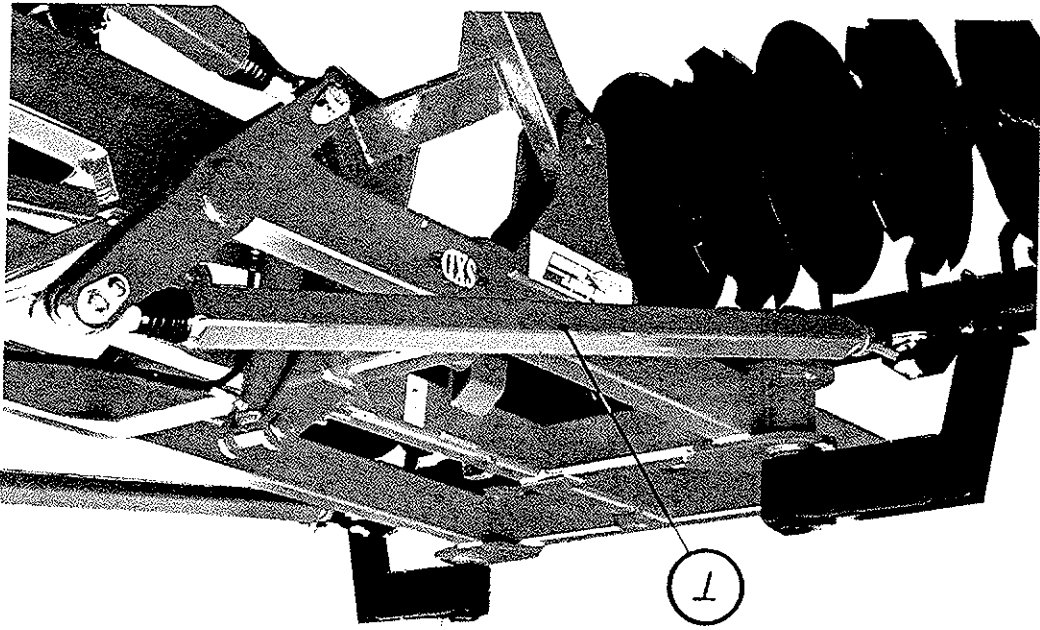

INCREASE OR REDUCE THE REAR DISC GANG ANGLE BY ACTING ON THE ADJUSTING ARM T

GANG ANGLE ADJUSTMENT

The trailed disc harrow **SXD - SX** is fitted with an hydraulic folding system.

This adjustment is made from the tractor cab by acting on the spool-valve which feeds the folding ram **A** (Fig. J).

A graduated slider **B** allows to respect an angle adjustment appropriate to the working soil nature. The relative opening position of the front and rear discs can be modified if necessary.

ADJUSTMENT :

- ☛ Put the machine into transport position
- ☛ Unfold the disc gangs.
- ☛ Modify if necessary the angle of the front disc gang by turning the tube **T** of the adjusting arms.

Find a proper balance between the angles opening and the working depth (see depth adjustment p. 12).

ROAD TRANSPORT

**FOR YOUR SAFETY AND THE SAFETY OF OTHERS
RESPECT THE FOLLOWING SAFETY INSTRUCTIONS:**



- ☛ The lifting system of the machine is fitted with a safety pin. Position the safety pin. (see view p. 9). It operates as a safety in case hose breaks during transport.
- ☛ When you hitch the machine to the tractor, check the drawbar height and also the fixation which locks the drawbar ring to the tractor drawbar / pick up hitch.
- ☛ In case the machine is fitted with a folding system during transport, put it into position. Be careful that nobody is standing near the machine.
- ☛ The use of the GREGOIRE-BESSON machines must always be made in accordance with the current directives and rules regarding road safety.
- ☛ Drive at a reasonable speed in conformity with the laws to be able at any time to control both tractor and machine.
- ☛ Do not drive when somebody is standing near the tractor or the machine.
- ☛ Comply with all the safety rules when driving, particularly on bends or on narrow roads.
- ☛ During road transport, the machine must be fitted with warning lights, which are to be removed during work to prevent them from damage.
- ☛ Take all the precautionary measures when you leave the tractor stopped motor, removed ignition key, apply hand brake on some models.
- ☛ During road transport, nobody is allowed to climb onto the machine or between the tractor and the machine.

To regularly check the state and the fixing of the ring hitches, not to hesitate to change the wearing parts.

ATTACHMENT TO THE TRACTOR

Make sure that the hydraulic spool-valves are clean before coupling the machine to the tractor.

Reverse the tractor near the drawbar ring.

Connect the spools of the lifting system.

Act if necessary on the screw holding the both compensation springs, by turning this screw, you modify the clearance between the coupling ring and the tractor fixation. Change if necessary the axle position in one of the both hoses situated at the end of the toothed bar (view 9).

Hitch the machine to the tractor by making sure that the drawbar angle is slightly higher.

Put the pin in which locks the drawbar ring to the tractor.

Put the machine into transport position.

When the machine is in transport position, check that the implement is parallel to the ground. Position the pin in the hole which comes through the ring and also depth limiting bar. This operation brings safety in case a hose breaks during road transport (view 2).

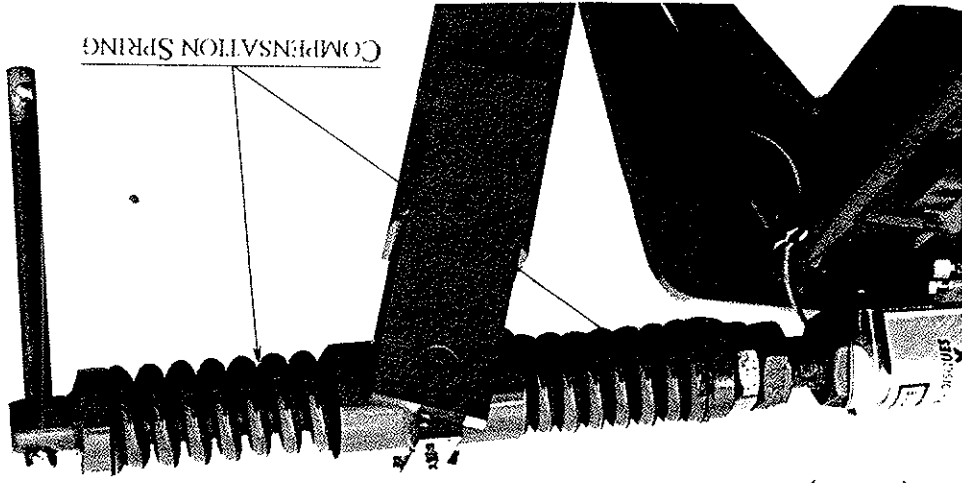

ATTACHMENT TO THE TRACTOR

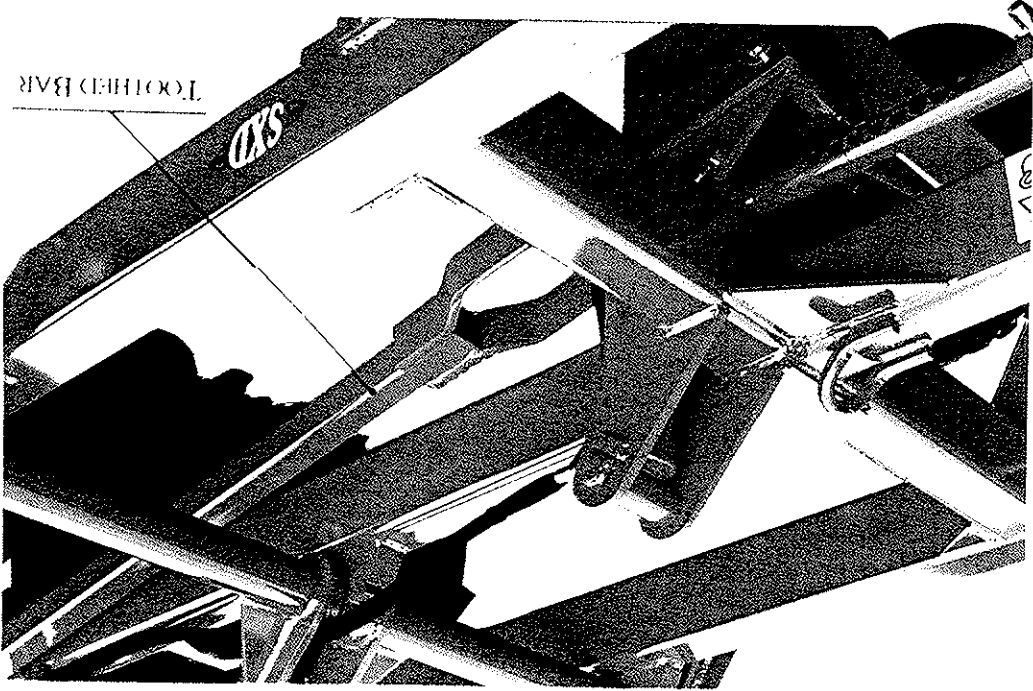

View 1

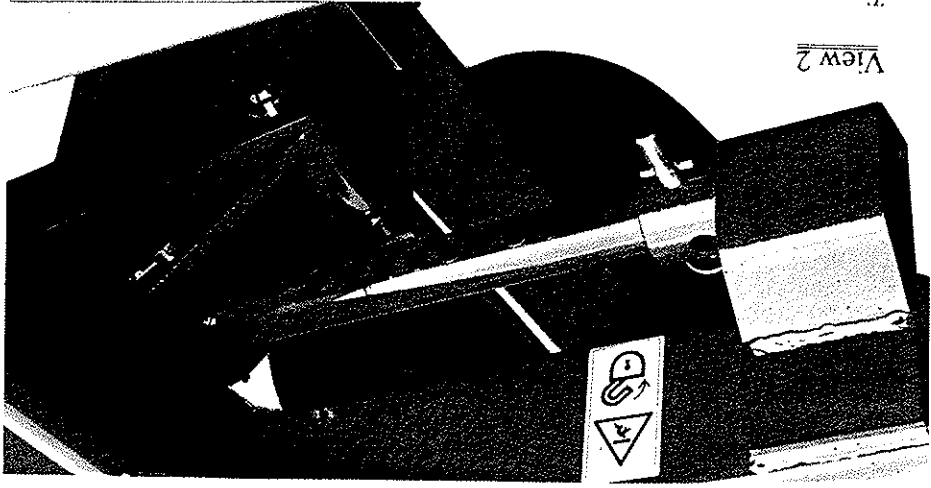

View 2

Transport position adjustment