

blocmaster

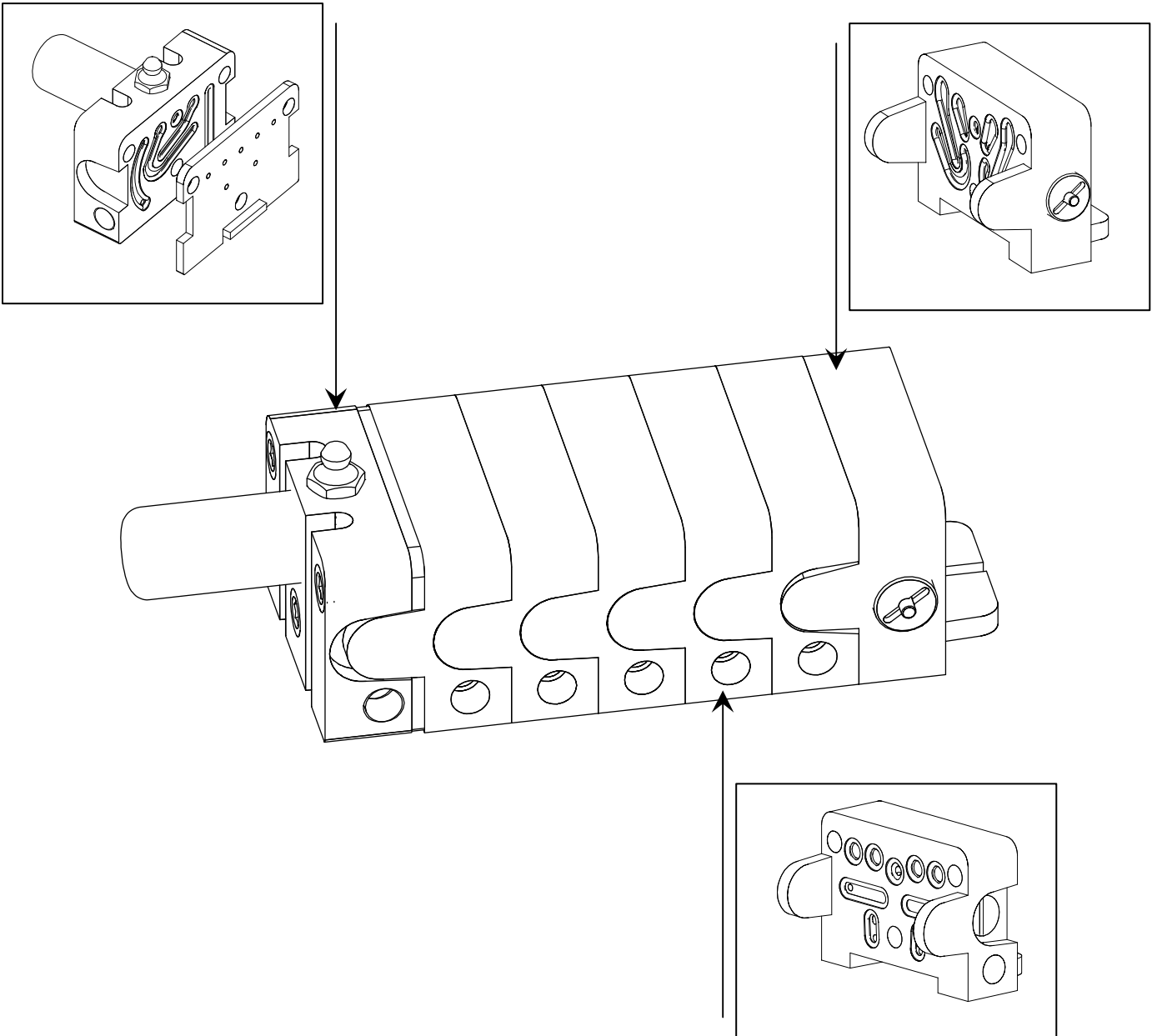

BLOCMASTER GUIDE



Unit15, Dabble Duck Industrial Estate, Shildon, Co. Durham DL4 2QN

Tel: 01388 775584 Fax: 01388 778893

Email: post@btconnect.com

www.bignall.co.uk

SYSTEM PRINCIPLE

The principle of progressive distribution is that each point is fed in turn through the system. Each block wafer has a piston which delivers grease from each end in predetermined ratios.

Each piston delivers in turn within the block, delivering its grease to an outlet port. Having moved it then opens the port to its neighbour which then delivers greaseand so on. The process continues down one side of the block and then the other. Each piston **MUST** therefore deliver for the cycle to continue.

Each of the distribution blocks is fitted with a cycle indicator pin. This pin moves in and out of the block as a visual confirmation that the block is cycling.

There are three piston sizes that give a nominal 0.05, 0.10 & 0.2cc outputs per side. By pre-drilling these; outputs may be twinned so both outputs deliver from just one side.

Blocmaster blocks may be used in a number of applications. A wide and flexible variety of configurations are available to suit both manually and automatically operated systems.

They consist of a reversing wafer containing a No. 20 piston which feeds two outlets and an start wafer that contain between them between 2 and 15 wafers each delivering to up to two points. In this way a single block can feed between 3 and 30 points. The blocks are held together by means of three studs and secured with T nuts.

A minimum of three pistons are required to cycle a block. Each wafer containing a piston delivers its output via the next block in line. Where all piston sizes in the block are the same (no.20) then blocks are usually unmarked. Where piston sizes in the block vary the outputs are marked either **5, 10 on the side of the block over each relevant outlet port.**

There are two main outlet threads available; 5/16" UNF suitable for Secondary Lines and M10 x 1.5 which is suitable for larger tubing or Primary Lines.

The Inlet thread is a 1/8" BSP; as standard this is fitted with a 1/8" BSP Straight Grease Nipple. Hydraulic fittings are available.

Marking	Output (cc)
	0.40
No Markings	0.20
10	0.10
5	0.05

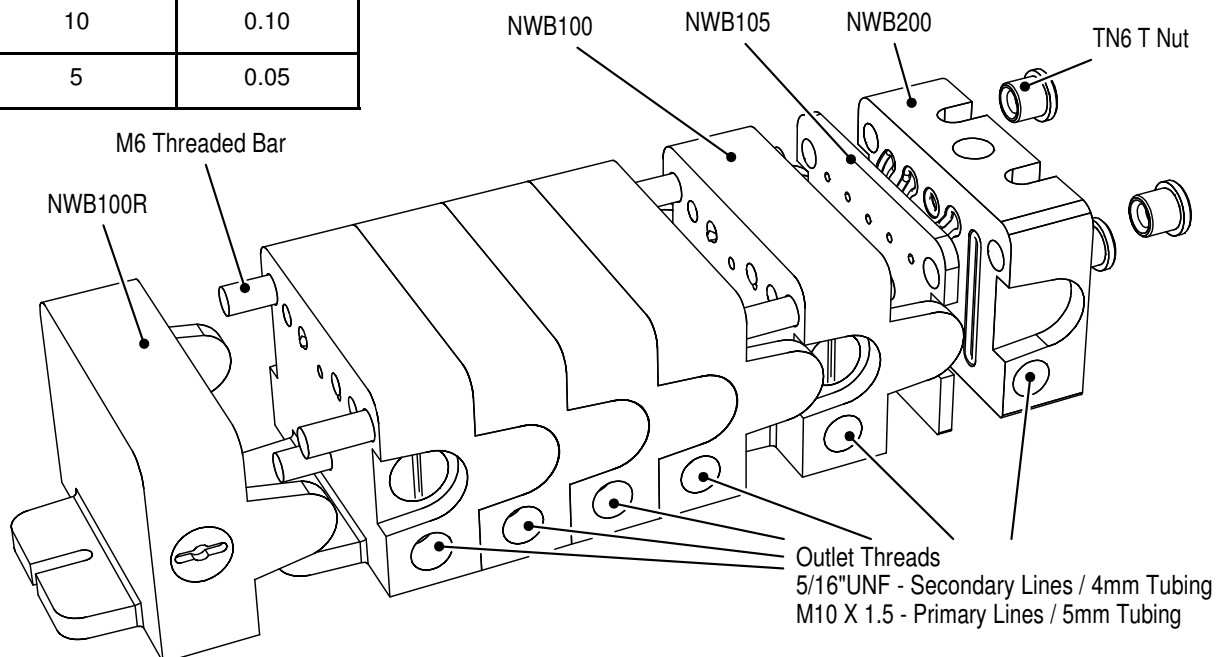

MANUAL SYSTEMS

These normally consist of an individual block close to the points to be fed. A pressure relief valve pre-set to 190 Bar is normally fitted to the block in such applications to protect the block & pipe-work from the very high pressures which can be created with hand grease guns. By the use of different size pistons and the option of twinning outlets ratios of 8 to 1 can be achieved within a single block.

DO NOT use a high-pressure air driven pump.

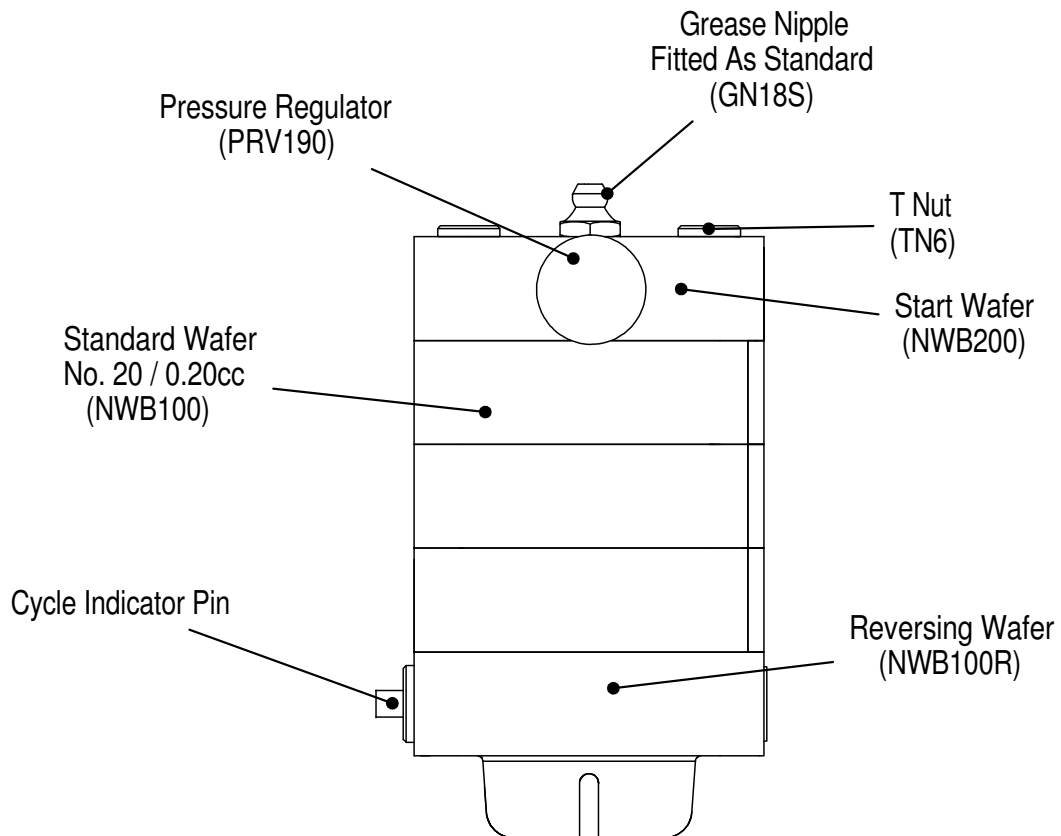

AUTOMATIC SYSTEMS

As these systems are generally more complicated; Masterlube Systems and their distributors are delighted to offer assistance with planning these applications.

Often automatic grease pumps feed a *master* bloc which in turn feeds a series of secondary blocs which feed the lubrication points. By this method large numbers of points can be fed from a single pump.

In these applications a pressure relief valve is fitted to the grease pump to limit the systems pressure to under 200 Bar.

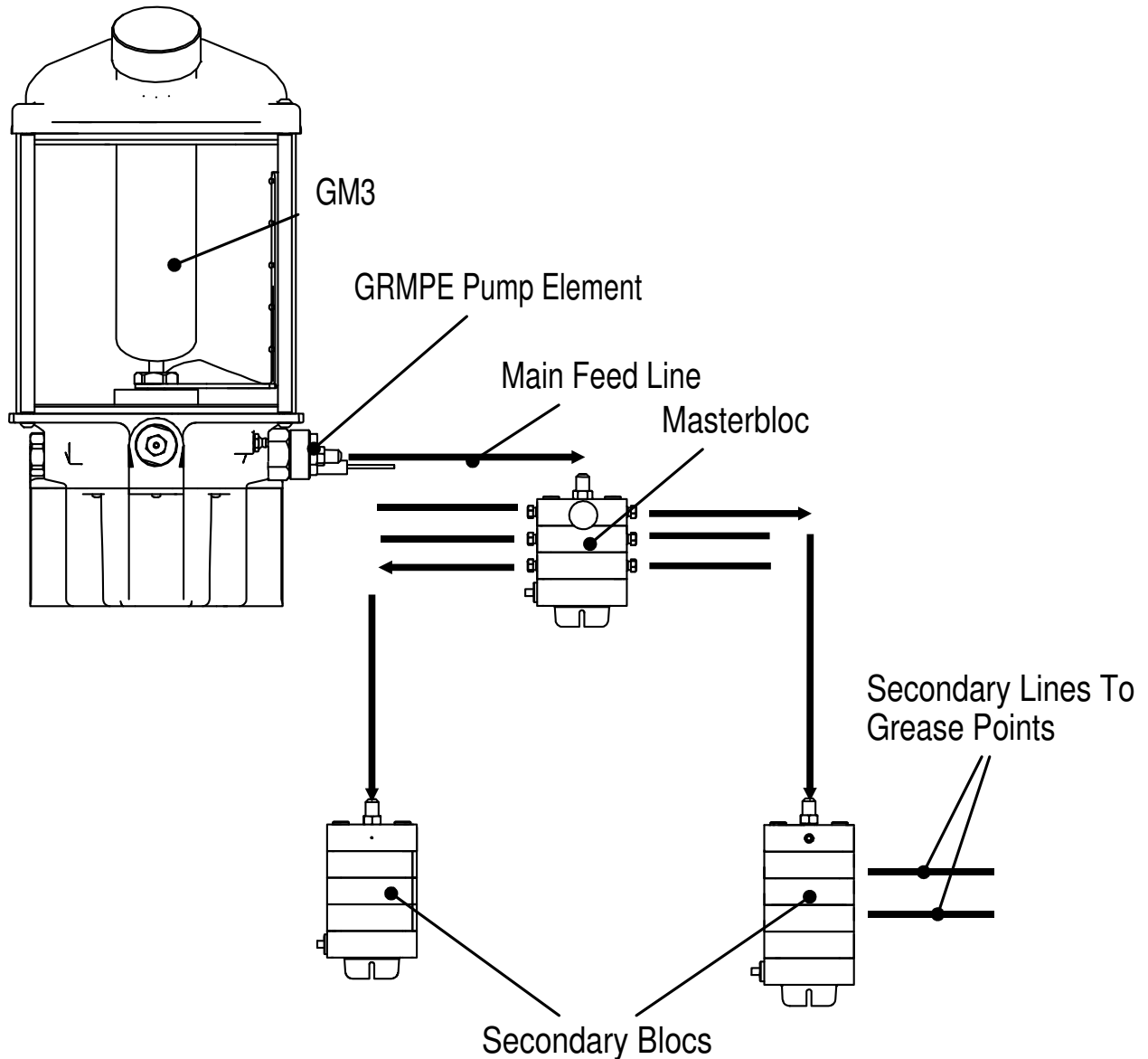

MOUNTING THE BLOCMASTER

To avoid block distortion the blocmaster must be mounted on a flat surface using the three mounting positions on the blocmaster. Use M6 through bolts or similar fixings.

Wafer spacers are available when ground clearance is needed.

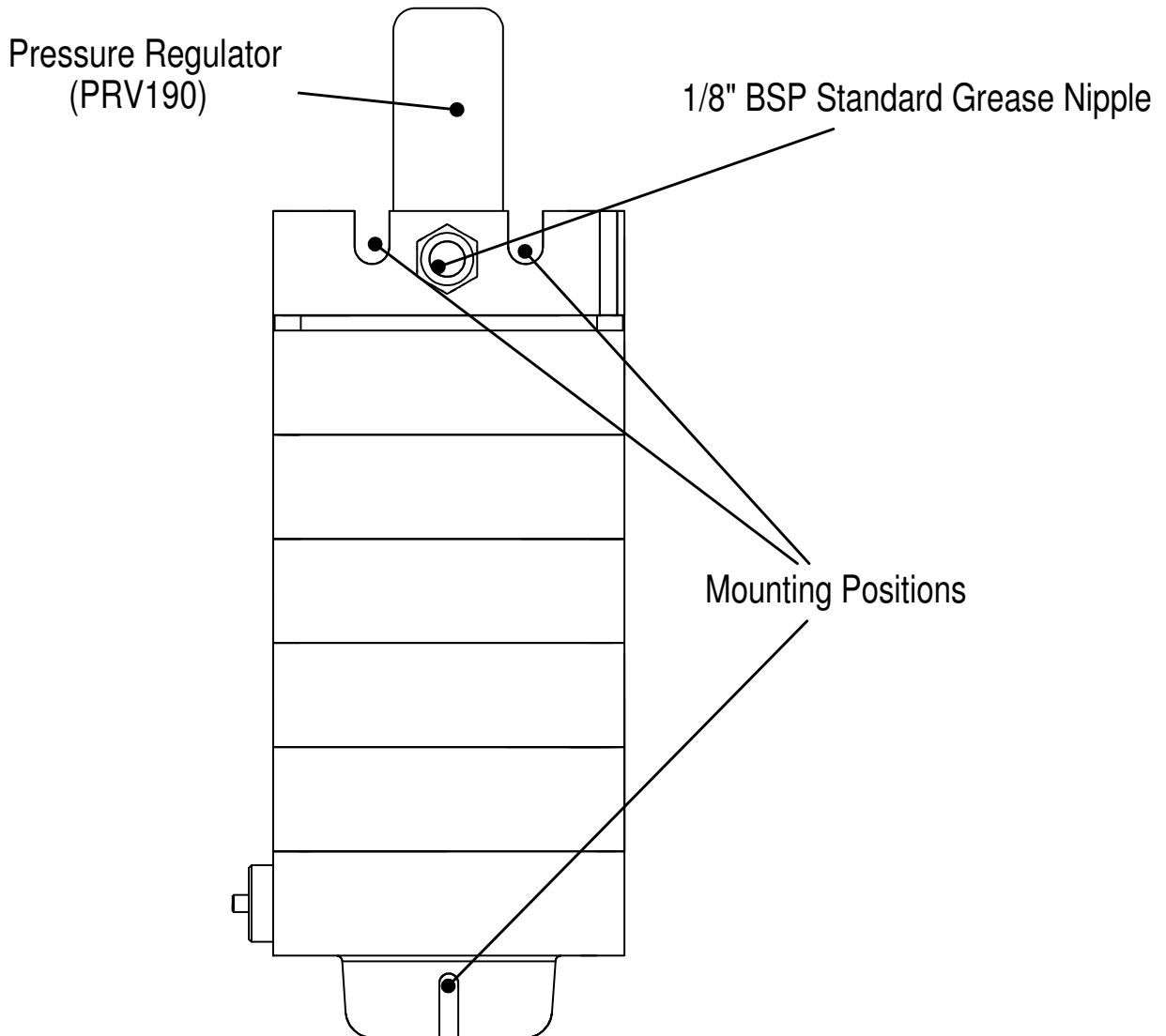

MICROSWITCH & WIRING DIAGRAM

The micro switch is fitted to the Primary Master Block; two wires (One Black, One Yellow) are attached to the Timer. The Black is connected to position 1(NC) on the GT3 Timer (See GT3 Operations Manual). The Yellow is connected to position 3(C) on the timer, then connect position 2 (NO) & 3 (C).

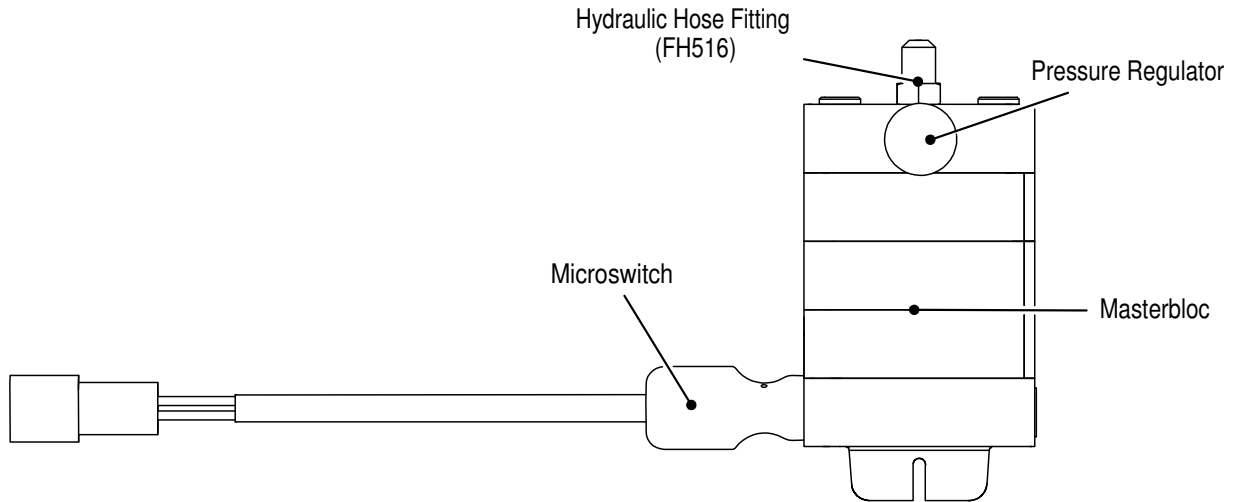

Wiring Diagram

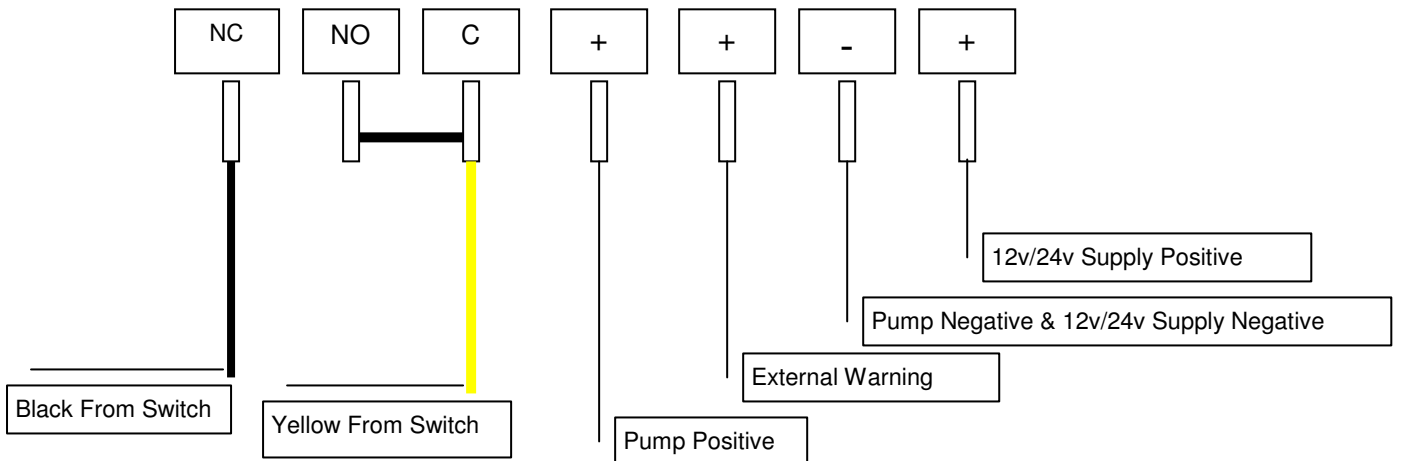

CARE & MAINTENANCE

CARE MUST BE TAKEN TO USE ONLY CLEAN GREASE

Avoid refilling grease gun from open containers and ensure all nipples/zerks are clean and free of dirt.

Examine all Pipe work regularly to ensure there is no damage. If a pipe is damaged, replace the pipe as soon as practical but **NEVER** blank off the outlet, as this will stall the block.

Grease released from open outlet due to damaged pipe-work will not affect the amount delivered to other points.

If points appear dry then disconnect and clear any blockage by greasing manually. Check that the pipe-work is not damaged.

NOTE: Larger bearings and those close to crop may appear dry but can still be adequately lubricated inside. If this is the case, low backpressure will be noted, and the expelled grease will not be discoloured.

DO NOT force grease into the blocks 'faster than it wants to go'

DO NOT use a high-pressure air driven pump.

It is recommended to operate the system at least once per day depending if operating conditions allow.

If a point is not regularly greased, dust and spent grease can block bearings causing grease to take longer to deliver or even stall the block.

New machines may take longer to grease due to tighter bearings.

IF UNDER LUBRICATION OR ANY OTHER PROBLEMS PERSIST CONSULT WITH YOUR NEAREST DEALER.

Information and contacts are available via:

www.bignall.co.uk

GREASE RECOMMENDATIONS

All Masterlube Greasemaster range of pumps are designed to operate with Lithium base NGLI grade 2 greases

These greases make up 70% of the current grease market.

Occasionally equipment manufacturers may recommend other greases for special reasons. Often this can be simply for the longer life properties. Where an automatic system is in use, clearly this requirement is already taken care of, however before reverting to a simple Lithium grade 2 grease the operator should check with the manufacturer to make sure the specification is not for the reason of other considerations such as shock loading, water ingress, heat etc.

Masterlube Greasemaster pumps will also pump other greases of NGLI grade 2 consistency, however when using these, the following points should be noted:

1. Although most of the more common grease bases will mix with our recommendation, (with the notable exception of Calcium), it is always advised to flush out the system before changing.
2. Lithium Complex and Lithium/Calcium Complex greases, although meeting NGLI grade 2 specifications, will be between 2 and five times harder to pump. This will lead to higher system pressures especially in colder weather. These greases are unlikely, however, to cause pressures exceeding the design parameters of the system.
3. Grease bases have a fibrous structure and in some cases these can be large enough to prevent it passing through the filter supplied with the Greasemaster II and 3 pumps. This will particularly be the case with Complex base greases and a few simple base greases where the manufacturing process has not fully homogenised the structure. In these cases it is open to the operator to either change greases (recommended), increase the frequency of filter cleaning or to remove the filter gauze. In the latter case it will then be necessary to take extra care when filling.
4. As well as oil and thickener (soap base) greases contain additives to enhance properties. These are unlikely to affect the system with the exception of Graphite which will build up on surfaces and effect tolerances.

All greases are subject to the gradual leaching out of oil over a period of time, this can cause blockages to occur within the system. This is not normally going to affect equipment which is in continual use. Where equipment is to be stood down for a period of months it is recommended to operate the system occasionally to move the older grease out of the system. It is also recommended that operators make their last fills with an NGLI grade 1 grease as this will slow the process