

HRP W 7

Fully mounted reversible plough

Hydraulic variable width

On land or in the furrow ploughing

OPERATOR'S MANUAL MAINTENANCE INSTRUCTIONS



GRÉGOIRE-BESSON S.A.

Rue Victor Grégoire
49 230 MONTFAUCON – MONTIGNÉ
France

Phone : 33 (0) 2 41 64 72 67
Fax : 33 (0) 2 41 64 67 73

Web : www.gregoire-besson.com
Email : Contactfr@gregoirebesson.com

June 2009

TABLE OF CONTENTS

1. INTRODUCTION	5
PRODUCT IDENTIFICATION	5
2. SAFETY INSTRUCTIONS	6
2.1. SAFETY STICKERS	6
2.2. SAFETY WHILE ATTACHING AND DETACHING	8
2.3. SAFETY WHILE CONNECTING HYDRAULIC LINES	8
2.4. SAFETY WHILE OPERATING MACHINE	8
2.5. SAFETY FOR MAINTENANCE	9
2.6. SAFETY FOR ON HIGHWAY TRANSPORT	9
3. MACHINE DESCRIPTION	10
3.1. IDENTIFICATION VIEWS	10
3.2. TECHNICAL SPECIFICATIONS	11
3.3. DIMENSIONS AND WEIGHTS	12
3.4. LIGHT AND SIGNS KITS	12
3.5. HEADSTOCK RHAS 115	12
3.6. HEADSTOCK TO MAIN FRAME LINKAGE	13
3.7. WORKING WIDTH	13
3.8. SAFETY DEVICES	14
<u>3.8.1. Shear bolt safety device type « B »</u>	14
<u>3.8.2. Non-Stop Hydraulic safety device</u>	14
3.8.2.1. Principle	14
3.8.2.2. Safety device type « Y »	15
3.8.2.3. Reinforced safety device type « Z »	15
4. PREPARING THE TRACTOR	16
4.1. REQUIRED HORSE POWER	16
4.2. TRACTOR WHEELS	16
<u>4.2.1. Tractor tyres</u>	16
<u>4.2.2. Distance between tractor tyres</u>	16
4.2.2.1. If tractor is on land = on land ploughing	16
4.2.2.2. If tractor is in the furrow = in the furrow ploughing	17
4.3. LIFT LINKS LENGTH	17
4.4. POSITIONING STABILIZERS	17
4.5. TOP LINK	18
4.6. FRONT END WEIGHTING	18
5. ATTACHING AND DETACHING	20
5.1. ATTACHING MACHINE TO TRACTOR	20
<u>5.1.1. Tractor equipped with tie rods lower links</u>	20
<u>5.1.2. Tractor equipped with automatic hooks lower links</u>	20
<u>5.1.3. Hitching top link</u>	21
5.2. DETACHING THE MACHINE	21
6. HYDRAULIC CONNEXIONS	22
6.1. REQUIRED HYDRAULIC REMOTES	22
6.2. REQUIRED HYDRAULIC PRESSURE	22
6.3. HYDRAULIC CONNECTIONS	22

7. PREPARING THE MACHINE	23
7.1. ADJUSTING POINTS LOCALIZATION	23
7.2. MACHINE WHEELS	24
<u>7.2.1. Tyre inflation</u>	24
<u>7.2.2. Wheel studs</u>	24
7.3. WORKING WIDTH ADJUSTMENT	24
7.4. ALIGNMENT ADJUSTMENT	25
<u>7.4.1. Principle</u>	25
<u>7.4.2. Adjustment</u>	25
7.5. FRONT FURROW ADJUSTMENT	26
<u>7.5.1. Principle</u>	26
<u>7.5.2. Adjustment</u>	26
7.5.2.1. Turn over operation	26
7.5.2.2. Field operation	26
7.6. PREPARING PLOUGH BOTTOMS	27
7.7. NON-STOP HYDRAULIC SAFETY DEVICE PRESSURE ADJUSTMENT ..	27
7.12. RJL = LATERAL DEPTH WHEEL	30
<u>7.12.1. Working position</u>	30
<u>7.12.2. Transport position</u>	30
7.13. RJR = REINFORCED DEPTH WHEEL	31
<u>7.13.1. Working position</u>	31
<u>7.13.2. Transport position</u>	31
7.15. DRL20 = LATERAL DUO WHEEL	33
<u>7.15.1. Working position</u>	33
<u>7.15.2. Transport position</u>	33
<u>7.15.3. Working depth adjustment range</u>	34
7.16. RTRH AND RCRH	
= HYDRAULIC DEPTH WHEEL WITH REALIGNMENT	
= HYDRAULIC COMBINED WHEEL WITH REALIGNMENT	35
<u>7.16.1. Hydraulic realignment principle</u>	35
<u>7.16.2. Assembly possibilities</u>	35
<u>7.16.3. Changing from working to transport position (RCRH)</u>	36
<u>7.16.4. Automatic engaging after changing to working position (RCRH)</u>	37
<u>7.16.5. Adjusting working depth</u>	38
<u>7.16.6. Hydraulic connexions</u>	39
7.16.6.1. Plough equipped with an automatic hydraulic alignment arm	39
7.16.6.2. Plough equipped with an automatic hydraulic front furrow width arm	39
7.16.6.3. Plough equipped with a memory ram for hydraulic variable width adjustment	39

8. TRANSPORTING	40
8.1. CHANGING TO TRANSPORT POSITION	40
8.2. CHANGING TO WORKING POSITION	41
8.3. DRIVING ON PUBLIC ROAD	41
9. FIELD ADJSUTMENT	42
9.1. FIELD UTILIZATION	42
9.2. FIRST PASS	42
<u>9.2.1. Entering into the ground</u>	42
<u>9.2.2. Alignment adjustment</u>	42
<u>9.2.3. Ploughing depth adjustment</u>	43
9.2.3.1. Tractor hydraulic hitch height adjustment	43
9.2.3.2. Tractor draft control adjustment	43
9.2.3.3. Gauge wheel height adjustment	43
<u>9.2.4. Side to side levelling = inclination adjustment</u>	43
<u>9.2.5. Front furrow width adjustment</u>	43
9.3. SECOND PASS	44
<u>9.3.1. Alignment adjustment</u>	44
<u>9.3.2. Front to rear levelling</u>	44
<u>9.3.3. Side to side levelling</u>	45
<u>9.3.4. Front furrow width adjustment</u>	46
9.3.4.1. If tractor is on land = on land ploughing	46
9.3.4.2. If tractor is in the furrow = in the furrow ploughing	46
9.4. SAFETY DEVICE ADJUSTMENT	47
<u>9.4.1. Shear bolt safety device type « B »</u>	47
<u>9.4.2. Non-Stop Hydraulic safety device type « Y » or « Z »</u>	47
9.5. SKIMMER ADJUSTMENT	48
<u>9.5.1. Shear bolt safety device</u>	48
<u>9.5.2. Skimmer height adjustment</u>	48
<u>9.5.3. Skimmer front to rear adjustment</u>	49
9.6. BOTTOM PITCH ADJUSTMENT	50
9.7. CCR 99 DISC COULTER ADJUSTMENT	51
<u>9.7.1. Front to rear adjustment</u>	51
<u>9.7.2. Depth adjustment</u>	51
10. MAINTENANCE	52
10.1. GENERAL INSTRUCTIONS	52
10.2. LUBRICATION	52
10.3. SPARE PARTS	54
10.4. WORKING BOTTOMS MAINTENANCE	54
10.5. STORAGE SAFETY	54
11. QUICKLY STARTING - HRP W 7	56

Any use and / or reproduction of all or part of this manual without written authorization from Grégoire-Besson is strictly prohibited.

NOTES

1. INTRODUCTION



READ CAREFULLY THIS MANUAL



To properly start, operate and service your equipment, follow all instructions given in this manual.

THIS MANUAL SHOULD BE CONSIDERED AS A PART OF THE EQUIPMENT AND SHOULD FOLLOW IT WHEN YOU SELL IT.

LEFT HAND SIDE AND RIGHT HAND SIDE, FRONT AND REAR are determined looking from equipment towards tractor when in work.

ALL INFORMATIONS, PICTURE, SPECIFICATIONS in this manual are based on the newer information available at the time of publication. Pictures and drawings might not represent standard equipment and show optional attachments.

Manufacturer reserves right to make any changes at all time **without any obligation to notice or to modify any delivered or already sold machine.**

If the machine has been modified in any way from the original design without written agreement from Grégoire-Besson, the manufacturer does not accept any liability for injury or warranty. Warranty would become void.



This symbol is used in the following manual to **catch your attention on warnings concerning your safety.**

So please when you see it in this manual or on the equipment, **strictly follow given information.**

Grégoire-Besson equipments are exclusively designed to be used by professionals for regular farm tillage in farmed fields. Manufacturer shall not be responsible for damage or injury resulting from any other use.

PRODUCT IDENTIFICATION

Please record here purchasing date, model and serial number of your equipment (refer to identification plate on hitch). Always refer to these information to get prompt and good service.

Fill and send back machine registration form for warranty.

Purchasing date :

Model :

Serial number :

Salesman's phone :

2. SAFETY INSTRUCTIONS

2.1. SAFETY STICKERS



READ OPERATOR'S MANUAL

Read operator 's manual and safety instructions before starting the use of your equipment and follow them while using.



Reference : UI 129



UNFOLDING AREA

Stay clear of equipment when folding or unfolding.

Reference : UI 126



MOVE AWAY FROM THE MACHINE

Danger in the working area, stay clear from the machine.

Reference : UI 127

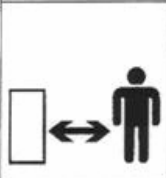

SECURE THE MACHINE BEFORE ACTION

Always install all lockup devices to secure machine before any intervention on it.

Reference : UI 131



HYDRAULIC LEAK AND MAINTENANCE

Caution, high pressure fluids can cause injury. Follow safe practices.

Reference : UI 128



Positioning safety stickers on the machine

When cleaning the machine, do not damage stickers.
Replace any damaged or missing sticker.

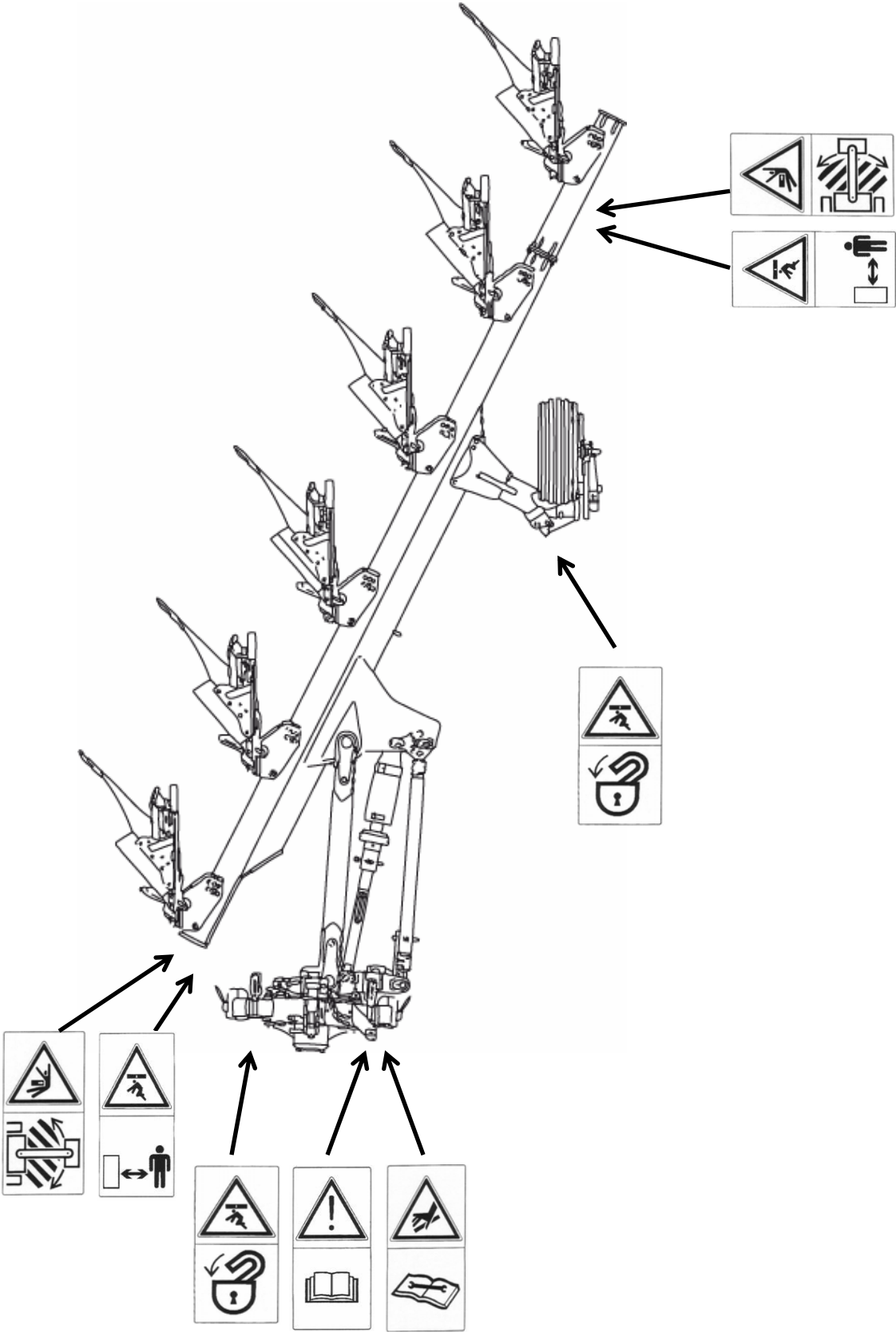

2.2. SAFETY WHILE ATTACHING AND DETACHING



- Do not let **anyone to stand between the machine and the tractor** when you back up to hitch.
- Before leaving the tractor to hitch or unhitch, set tractor parking brakes.
- Never attempt to attach the machine if pins, tractor hitching balls, tractor drawbar, or machine linkage are worn, cracked or not compatible.
- Completely lower the machine to the ground before unhitching. Make sure it is on a level and firm surface.
- Remove pressure from hydraulic lines before disconnecting them.
- Before leaving the machine for storage, make sure it is in a safe place and that there is no risk to damage whether anything or anyone.

2.3. SAFETY WHILE CONNECTING HYDRAULIC LINES



- Hydraulic circuit might be highly pressurised.
- **Never use your hands to locate a hydraulic leak.** Hydraulic fluids escaping under pressure have sufficient force to penetrate the skin, causing severe injury. In case of any injury, **see a doctor immediately.**
- For equipments loaded with several hydraulic connectors, **make logical and appropriated connections.**
- Before connecting hydraulic circuit, **make sure that there is no pressure on both sides (tractor and machine).**
- Regularly check hydraulic lines and connections. **Replace any damaged or leaking component** by an original part with the same specifications.
- Before any intervention on hydraulic circuit, **lower machine to the ground and release pressure moving control lever in the tractor's cab.**

2.4. SAFETY WHILE OPERATING MACHINE

- **Never attempt** any intervention on the machine while it is in motion.
- Do **not** allow anyone to **stand close to pivot points** : bottoms safety device (shearing bolt or non-stop), all pivoting linkage.
- Wear close **fitting clothing** and **appropriate safety devices** for the job you have to do (heavy leather gloves, safety shoes, earplugs, ...).
- Do not allow anyone to stand close to the machine.
- Do not attempt to do any adjustment if you have not perfectly understood its procedure.
- Always use tools or equipments appropriate to the job you are doing. All Grégoire-Besson equipments are metric standards.
- Learn how to operate your machine and how to use its controls. Do not let anyone operate without instruction.
- Do not extend turnbuckle adjusters too much to avoid any threads damaging or intempestive pulling out.
- Only one person (the operator) should be in the tractor's cab when it is in operation. **No one on the machine while working or travelling on the road.**
- When earring or feeling unusual vibrations, stop the machine. Find the problem and solve it before starting operating again.



If your machine is equipped with a hydraulic folding mechanism, **always use it from tractor's cab**, once you are sure that folding area is free from spectators or obstacles.

2.5. SAFETY FOR MAINTENANCE



- Maintenance area shall be **clean, dry, with enough light and ventilation**.
- For any intervention on the machine in raised position, **always securely support all components** before starting maintenance.
- **Maintenance operations on elements under pressure or under tension** (resorts, accumulators, ...) require specific procedure and equipments. **Only qualified persons shall perform them in appropriate conditions.**
- After servicing remove all tools, components and parts you used.
- Regularly **check tightness of wheel studs, wearing parts bolts, and all other bolts and nuts.**
- **Always use genuine parts corresponding to manufacturer's technical specification requirements.**

2.6. SAFETY FOR ON HIGHWAY TRANSPORT



FOR YOUR OWN SAFETY AND THE ONE OF THE OTHER, RESPECT THE FOLLOWING RULES :

- All Grégoire-Besson equipments shall be used **complying with area's current rules and laws** concerning **safety instructions, accident prevention and provision of Highway Code**.
- Before road transport, always **check for wheels studs** and wheels mounting brackets carriage bolts **tightness** ; **check tyres general state and pressure** : do not drive with low pressure, cuts or damaged tyres or rims.
- **Use all devices required by your area's current laws** (lights, reflectors, signs, ...). They might be removed during field operation to prevent from any damage. It is the operator's responsibility to comply with current law and to follow its evolutions.
- Regularly check hitching pins, change them if necessary. Tractor's ball joint may also wear, do not hesitate to replace them with new ones having at least Waltersheid fabrication quality.
- Drive **at reasonable speed** complying with local laws **to always keep control** of tractor and equipment. Pay special attention on irregular or rough roads. **Do not attempt to drive down a hill faster than it could be possible to drive it up.**
- Tractor used for road transport shall have the same power rating and weight as the one used for field operations.
- **Never attempt any manoeuvre if area is not free from spectators.**
- If your machine is equipped with a **folding mechanism** (manual or hydraulic), **use it making sure folding area is free from spectators** and obstacles.
- Follow all **safe driving practices** when travelling, moreover **on corners, rough or narrow roads**.
- When **leaving tractor** even for a short period, **shut off engine, remove ignition key and set parking brakes**.
- Forbid anyone to stand between tractor and machine or on the machine travelling on the road.

3. MACHINE DESCRIPTION

3.1. IDENTIFICATION VIEWS

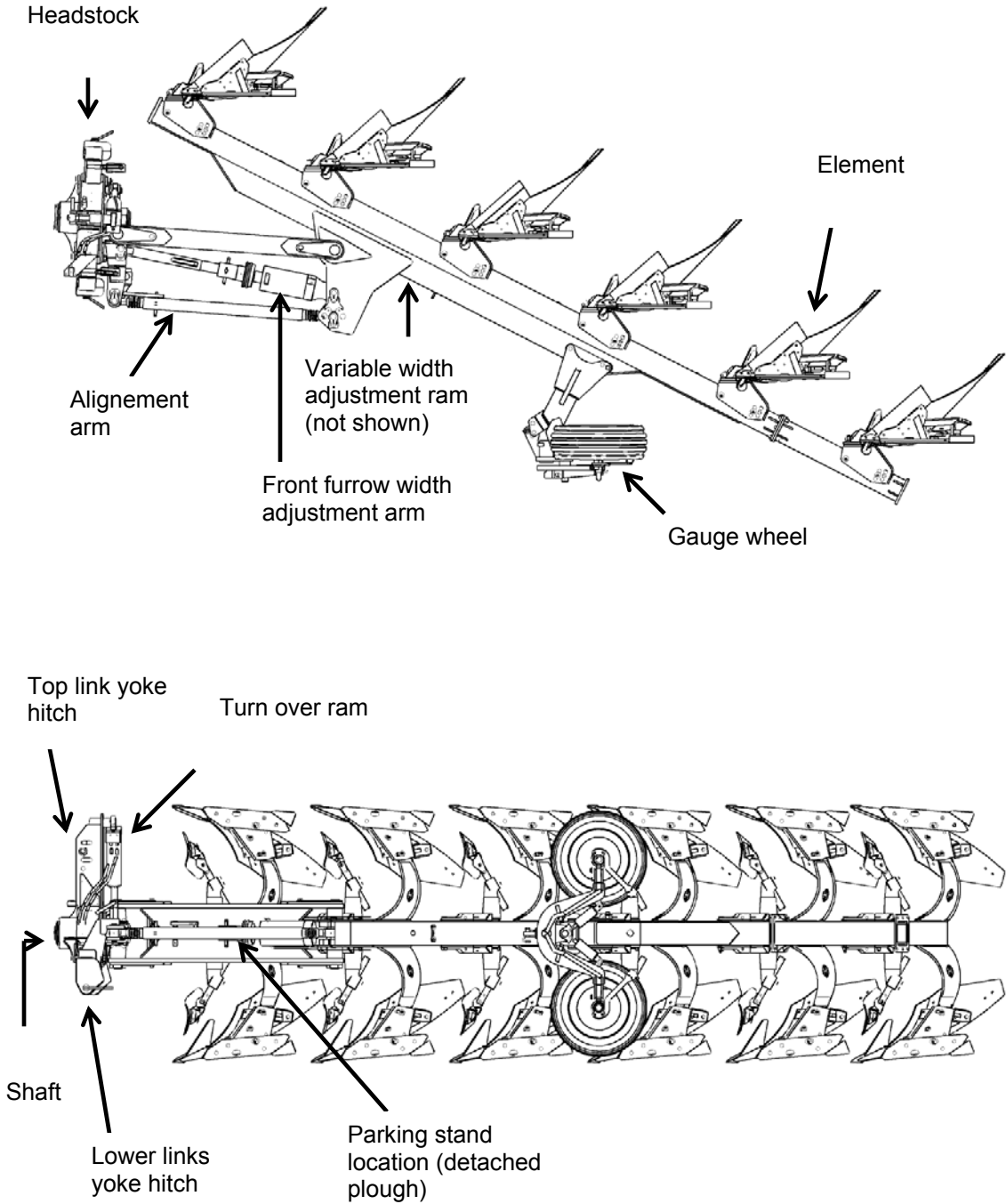

3.2. SPECIFICATIONS TECHNIQUES

Specification	Standard equipment	Optional equipments
Turn over	<ul style="list-style-type: none"> Hydraulic with ram, type RHAS 115 Inclination adjustment by independent screw Automatic box for plough alignment through front adjuster for turn over 	
Frame	<ul style="list-style-type: none"> Main frame 150 x 150 mm doubled up to last but one furrow Possible addition of 1 extra bottom on 4 and 5 furrows 	
Working width	<ul style="list-style-type: none"> Hydraulic variable width from 12" to 20" 	
Alignment adjustment	<ul style="list-style-type: none"> With mechanical turnbuckle 	
Front furrow width adjustment	<ul style="list-style-type: none"> With hydraulic automatic arm 	
Inter body clearance	<ul style="list-style-type: none"> 90 cm (= 35") 100 cm (= 39") 	<ul style="list-style-type: none"> 114 cm (= 45")
Pont to point height	<ul style="list-style-type: none"> 160 cm 170 cm 	<ul style="list-style-type: none"> 180 cm
Safety device	<ul style="list-style-type: none"> Shear bolt (B) Non-Stop Hydraulic (Y) 	<ul style="list-style-type: none"> Non-Stop Hydraulic reinforced (Z)
Hydraulic	<ul style="list-style-type: none"> 1 DA direct plug in tractor spool turn over + automatic re-alignment through front adjuster 1 DA direct plug in tractor spool hydraulic working width adjustment 	
Wheel	<ul style="list-style-type: none"> Choice of depth wheels (optional transport kit) or combined wheels, rear or laterally positioned 	
Bottoms	<ul style="list-style-type: none"> 16" self sharpening shares with reversible points or square bar point 35 mm Mouldboards helicoïdal short (H4 / H5), or American (3A / 5A), or Cylindrical standard (C 14 / C 16) or Cylindrical flat (P 14 / 16) Landside wearing plates Pitch adjustment Knife coulter 	<ul style="list-style-type: none"> Choice for mouldboards : helicoïdal long, plastic, scattered Mouldboard extensions Choice for share width : 14", 16", 18"
Skimmers	<ul style="list-style-type: none"> Adjustable front to rear & up and down Shear bolt safety device Type mixed, manure or trash covers instead of skimmers 	<ul style="list-style-type: none"> Type maize, euro, universal or pasture

A large choice of options is available to improve machine's job.

Grégoire-Besson authorized dealers know area and working conditions. They may give information according to technical choices and latest equipments evolutions.

Grégoire-Besson is also represented on farm equipment shows.

3.3. DIMENSIONS AND WEIGHTS

Nb of furrows	Inter body clearance	Working width		Over all length (approx.)	Indicative weight (B)	Indicative weight (Y)
4	90 cm	12" to 20"	1.2 to 2.0 m	5.50 m	2 100 kg	2 220 kg
5	90 cm	30 to 50 cm	1.5 to 2.5 m	6.50 m	2 400 kg	2 550 kg
6	90 cm		1.8 to 3.0 m	7.50 m	2 700 kg	2 880 kg
4	100 cm	12" to 20"	1.2 to 2.0 m	6.00 m	2 150 kg	2 270 kg
5	100 cm	30 to 50 cm	1.5 to 2.5 m	7.00 m	2 450 kg	2 600 kg
6	100 cm		1.8 to 3.0 m	8.00 m	2 750 kg	2 930 kg

Dimensions and weights are indicative and subject to variations according to equipments and options.

Type of wheel	Type of tire		
	200 x 14.5	10.0 / 75 x 12	320 - 60 x 12
RJR	100 kg	105 kg	108 kg
RJL	65 kg	70 kg	73 kg
DRL20	170 kg	175 kg	-
RTRH	145 kg	150 kg	153 kg
RCRH	185 kg	185 kg	188 kg

Note : after use, ground or residue accumulations may increase machine's weight.

3.4. LIGHT AND SIGNS KITS

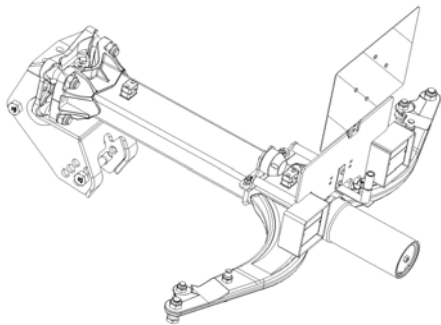

Light and signs kits are available for all Grégoire-Besson equipments. Contact an authorized dealer.

3.5. HEADSTOCK RHAS 115



Plough is equipped with a reinforced fully welded headstock RHAS 115 type :

- two hitch heights are available : for an optimal tractor + plough behaviour, machine shall be attached as low as possible
- a 115 mm diameter shaft loaded on two identical taper roller bearings
- two mechanical depth stoppers for inclination adjustment, R.H. and L.H. independent

3.6. HEADSTOCK TO MAIN FRAME LINKAGE

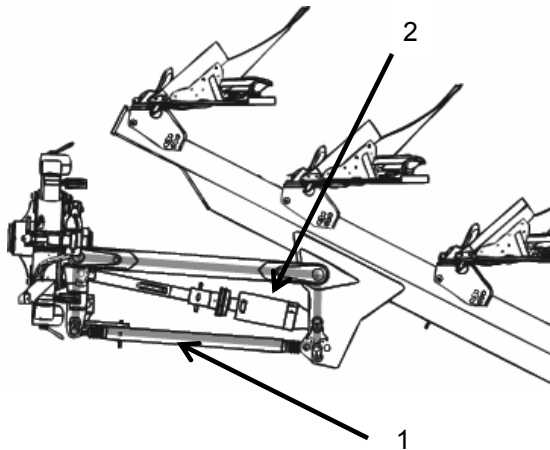

Headstock is linked to main frame via a parallelogram (refer to picture).

Two independent arms allow plough adaptation to all conditions :

- alignment arm (1) : to line up the plough behind the tractor,
- front furrow width adjustment ram (2) : to adjust front furrow width of cut.

Machine is equipped with a wide front adjuster allowing on land ploughing (maximum admissible over all width : 3.50 m) or in the furrow ploughing (minimum admissible intertyre distance : 1.45 m).

As a standard assembly, machine is equipped with an automatic box for alignment through front adjuster before turn over.

3.7. WORKING WIDTH

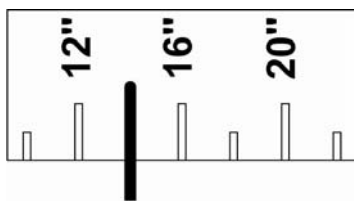

Machine working width is « on the go » adjustable. This adjustment is done by a double acting ram and an external double rod linking elements all together.

Individual working width goes from 12"to 20".

3.8. SAFETY DEVICES

3.8.1. Shear bolt safety device type « B »

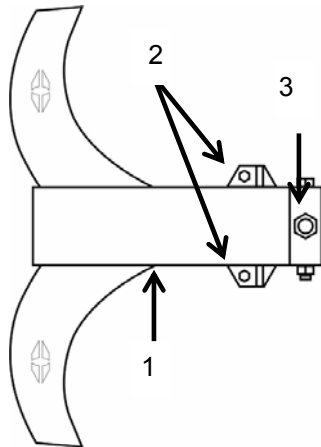

Two bolts (2) hold element (1) in position. When hitting an obstacle, both bolts shear for the complete bottom to trip, pivoting around its articulation (3).

In case of safety bolts shearing, replace them by a new ones, certified genuine Grégoire-Besson.

Point to point height	VI 31 06 + VJ 324 Screw HM16x50 grade 8.8 Nyloc nut H M16	VI 31 07 + VJ 324 Screw HM16x50 grade 10.9 Nyloc nut H M16
160 cm	4 800 kg	6 000 kg
170 cm	4 500 kg	5 700 kg
180 cm	4 200 kg	5 400 kg

Pressure on point for B safety device tripping.

3.8.2. Non-Stop Hydraulic safety device

3.8.2.1. Principle

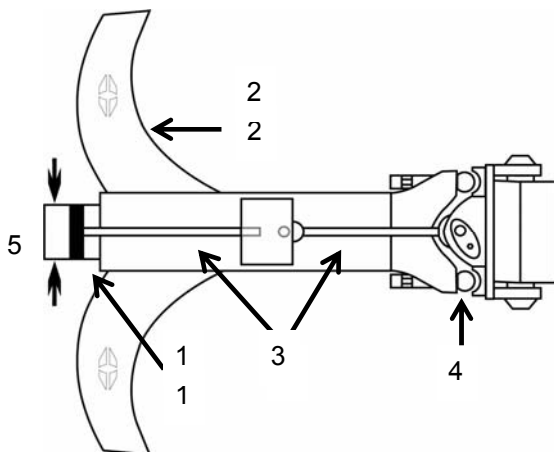

At the rear each element (2) has a safety ram (1). This ram is linked to the frame by a two parts rod (3), allowing 850 mm as ground clearance.

At the front, each element has four ball bearings (4) to hold it on the frame.

All safety rams are connected on the same hydraulic circuit also composed by a gas accumulator and a gauge to be able to check pressure at any time.

Hitting an obstacle, when pressure at the point becomes higher than pressure in the circuit, bottom will trip, sending oil into the accumulator. When obstacle is gone, pressure at the point

decreases, accumulator releases oil and bottom comes back to its position.

Pressure in the hydraulic circuit is adjustable. **Always stay in the green zone on the gauge.**

If it is necessary, there are two ways to reach higher resistance :

- using safety rams with larger diameter (5) : diameter is measured at the rear of the ram,
- using accumulator with larger pressure capacity : capacity is written on accumulator whether on a sticker or on a plate.

Note : it might be more interesting to choose an accumulator with larger pressure capacity : wider utilization flexibility, changing is fast and easy on an already delivered machine, no price difference between the two accumulators.

3.8.2.2. Safety device type « Y »

Safety device type « Y » allows under point height 850 mm approx.

	Standard assembly	Optional assembly (standard for height 180 cm)
Ram Ø on 1st bottom	100 mm	110 mm
Ram Ø on other bottoms	90 mm	100 mm
Accumulator	6 litres - 100 bars	6 litres - 150 bars

Components of Y Non-Stop Hydraulic safety device circuit.

Point to point height	Safety ram Ø	Accumulator 100 bars		Accumulator 150 bars	
		Pressure min 110 bars	Pressure max 150 bars	Pressure min 160 bars	Pressure max 200 bars
160 cm	90 mm	624 kg	850 kg	907 kg	1 135 kg
	100 mm	806 kg	1 110 kg	1 173 kg	1 466 kg
	110 mm	1 008 kg	1 375 kg	1 466 kg	1 832 kg
170 cm	90 mm	591 kg	806 kg	860 kg	1 075 kg
	100 mm	764 kg	1 042 kg	1 110 kg	1 390 kg
	110 mm	955 kg	1 302 kg	1 390 kg	1 730 kg
180 cm	90 mm	561 kg	766 kg	817 kg	1 020 kg
	100 mm	726 kg	990 kg	1 055 kg	1 320 kg
	110 mm	907 kg	1 237 kg	1 320 kg	1 650 kg

Pressure on point for Y Non-Stop Hydraulic safety device tripping.

3.8.2.3. Reinforced safety device type « Z »

Safety device type « Y » allows under point height 700 mm approx.

	Standard assembly	Optional assembly (standard for height 180 cm)
Ram Ø on 1st bottom	100 mm	110 mm
Ram Ø on other bottoms	90 mm	100 mm
Accumulator	6 litres - 100 bars	6 litres - 150 bars

Components of Z Non-Stop Hydraulic safety device circuit.

Point to point height	Safety ram Ø	Accumulator 100 bars		Accumulator 150 bars	
		Pressure min 110 bars	Pressure max 150 bars	Pressure min 160 bars	Pressure max 200 bars
160 cm	90 mm	706 kg	962 kg	1 026 kg	1 284 kg
	100 mm	912 kg	1 244 kg	1 327 kg	1 658 kg
	110 mm	1 140 kg	1 555 kg	1 658 kg	2 073 kg
170 cm	90 mm	670 kg	912 kg	973 kg	1 217 kg
	100 mm	865 kg	1 179 kg	1 258 kg	1 572 kg
	110 mm	1 081 kg	1 474 kg	1 572 kg	1 965 kg
180 cm	90 mm	636 kg	868 kg	925 kg	1 157 kg
	100 mm	822 kg	1 121 kg	1 196 kg	1 495 kg
	110 mm	1 028 kg	1 401 kg	1 495 kg	1 869 kg

Pressure on point for Z Non-Stop Hydraulic safety device tripping.

4. PREPARING THE TRACTOR

Follow recommendations given in the safety section of this manual. They are not restrictive.

4.1. REQUIRED HORSE POWER

Tractor requirements may vary according to ground and working conditions (type of soil, type of tractor, type of tyres, ...). Following data are only indicative. Ask an authorized Grégoire-Besson dealer for any further information.

Number of furrows	Indicative HP requirements
4	120 - 160 HP
5	150 - 200 HP
6	180 - 240 HP

4.2. TRACTOR WHEELS

4.2.1. Tractor tyres

Check tractor tyres general state and pressure. Pressure should be the same on both sides of the tractor for a nice drivability in the field and on the road.



IMPORTANT : inflate tyres following manufacturer's recommendations.

4.2.2. Distance between tractor tyres

Generally, using a plough with large number of bottoms, the wider is the distance between tyres, the better is the drivability.

It is recommended to line up the middle of the front axle with the middle of the rear axle.

4.2.2.1. If tractor is on land = on land ploughing

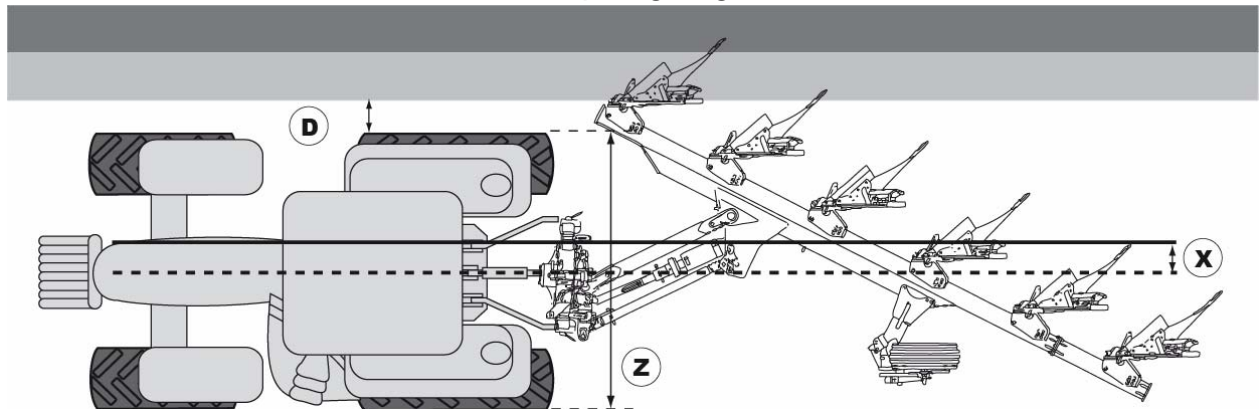

Generally tractor + on land plough have an optimal drivability when tractor traction line (dotted line on here above picture) and on land plough resistance line (full line) are as close as possible = **when distance X is minimum**.

A minimal clearance shall be let between the furrow wall and the external side of tractor's rear tyre = **distance D at least 15 cm**.

Maximum admissible over all length for tractor = **distance Z : 3.50 m**.

4.2.2.2. If tractor is in the furrow = in the furrow ploughing

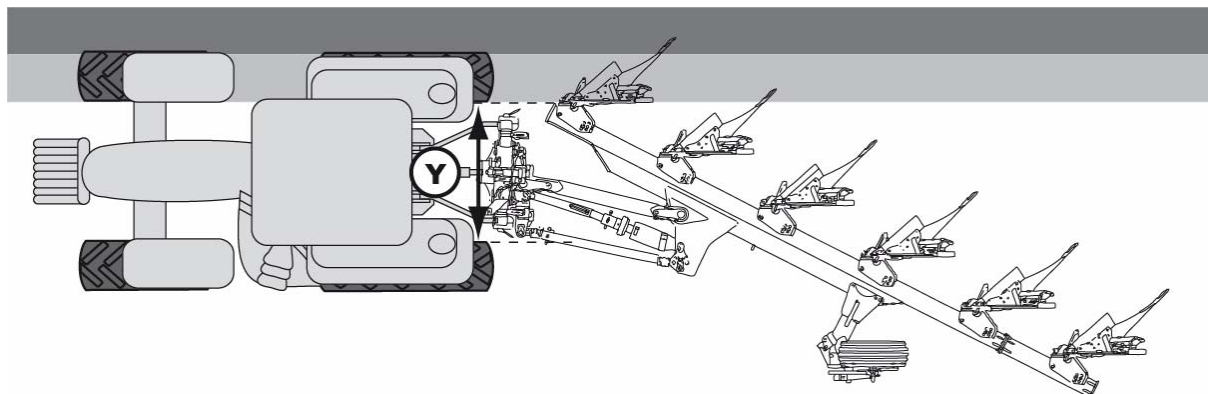

Front furrow ram adjustable stoppers shall be set so that once tractor runs in the furrow front element cuts the same width as the other ones. Then ploughing is even. Refer to section 7.5.

Minimal inter rear tyre distance = distance Y : 1.45 m.

4.3. LIFT LINKS LENGTH

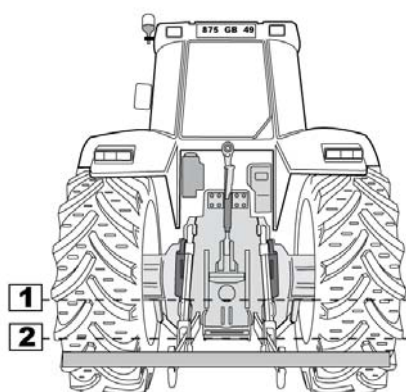

Lift link arms length determines tractor hitch levelling and lift cylinder position at working depth.

- Set lift links length so that tractor hitch is level (refer to picture).
- Set lift links length to have at least 30 mm clearance on lift cylinder rod when machine is working at desired depth. This will give adjustment possibilities for front gang depth from tractor's cab and allow efficient tractor draft control

4.4. POSITIONING STABILIZERS

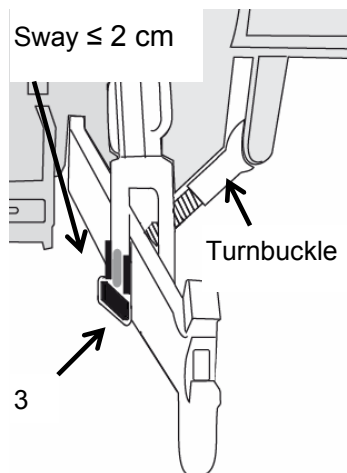

To hitch a fully mounted equipment; stabilizers shall be positioned so that :

- **in transport position** : lift links arm have **minimum sway (≤ 1 cm)**. This will prevent from chocks between machine and tractor during manoeuvres or transport
- **in working position** : lift links arms shall have **2 to 5 cm** loose.

If necessary, install bushings to avoid lateral movement of hitch arms on hitch pins. Always check for compatibility between hitch pins and bushings (\emptyset and length).

Note : it is easier to adjust and / or service stabilisers bolts and threads before hitching the machine.

Horizontal lift links pins (3) shall be in fixed position to avoid any loose and / or damageable shock.

4.5. TOP LINK

Before attaching the machine, make sure that thread length is the same on both sides of top link. Refer to picture, A shall equal B.

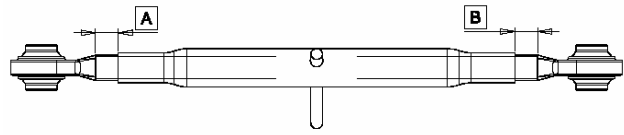

Top link length will be adjusted in the field.

NOTE : an excess of grease inside top link tube may make it impossible to shorten. Remove grease fitting to let grease free to go out.

IMPORTANT : connection between machine and top link shall be done through a tie rod and never through an automatic hook.

- Automatic hooks sizes and designs change according to models and manufacturers and may cause interference with machine hitch in particular conditions.
- Spring shutter may block hitch ball which may wear or break. This is particularly true for hitches cat III: pin diameter is larger giving less quantity of matter for the ball becoming less strong.

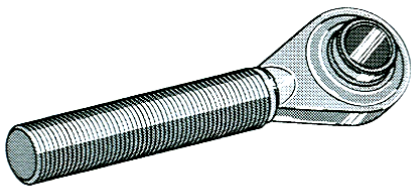

Example of tie rod
CORRECT

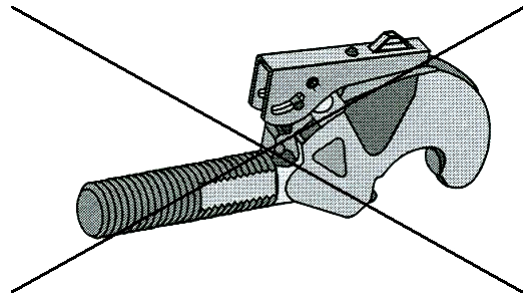

Example of automatic hook
DO NOT USE

Do not hesitate to contact an authorized Grégoire-Besson dealer for any further information.

4.6. FRONT END WEIGHTING

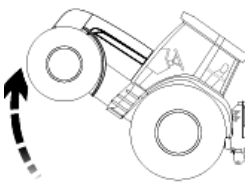

Wheels weights (front and rear) and front end weights may be required to avoid excessive slippage and to increase stability in rough and sloppy grounds.

Weights shall not be added once all slippage is eliminated. Refer to tractor operator's manual and to tractor's dealer. Follow tyre manufacturer's recommendations.

NOTES

5. ATTACHING AND DETACHING

Follow recommendations given in the safety section of this manual. They are not restrictive.

IMPORTANT : always make sure that hitching never leads to :

- overload : respect maximum hitch capacity
- unbalance: load tractor front end if necessary. Refer to section 4.6.

5.1. ATTACHING MACHINE TO TRACTOR

5.1.1. Tractor equipped with tie rods lower links

- Before any manoeuvre, check for diameter and length compatibility between hitch pins and tractor tie rods.
- Remove safety bolts and hitch pins.
- Back up tractor to line up tie rods and machine hitch holes.
- Install pins and secure them with their safety clips.
- If holes are difficult to line up : extend telescopic arms as indicated in tractor operator's manual. Once hitch pins are inserted and secured with their safety clips, slowly back up tractor to lock back lift arms. Check for lift arms locking.
- Hitch top link.

5.1.2. Tractor equipped with automatic hooks lower links

- Remove safety bolts and hitch pins.
- Remove balls from tractor lift link automatic hooks.
- Check for balls and pins general state and compatibility.
- Install balls on pins through lower machine hitching holes. Secure with safety bolts.
- Slowly back up tractor till automatic hooks are lined up underneath hitch balls.
- Raise tractor hitch about 5 cm above ground surface till automatic hooks are locked.
- Check for automatic hooks latch handles good locking.
- Hitch top link.



IMPORTANT : before hitching top link, **make sure to have enough clearance between machine yoke hitch and tractor lower lift links to avoid any possibility of contact from working to raised position. A second verification shall be done once machine is in the field in truth working conditions.**

Note : if headstock is not horizontal, use turn over memory ram to level it. This will make attaching manoeuvre easier and safer.

5.1.3. Hitching top link

Connexion between top link and machine has to be done through a tie rod (refer to previous section).

Once tractor lift links are correctly hooked up, check top link general state and compatibility with tie rod. Then attach top link in one of the three available slots.

Raise machine to the maximum and make sure there are no interference with tractor. Final top link adjustments (length and position) will be made in the field.

Put parking stand in working position : remove safety clip and pivot it into horizontal position. Do not forget to install safety clip back.



IMPORTANT : make sure to have enough clearance between machine yoke hitch and top link to avoid any contact from working to raised position. A second verification shall be done once machine is in the field in truth working conditions.

Connect hydraulic lines.

5.2. DETACHING THE MACHINE

Before detaching, make sure that ground is flat and firm enough to support the machine. Use safety blocks to support machine components if necessary.



DANGER : do not let any part of your body underneath the machine when lowering it to the ground.
Crushing may lead to death.

Proceed in the logical attaching opposite way :

- 1) Put machine in working position = it shall stay on its bottoms L.H. or R.H. side
- 2) Put stand in parking position = vertical
- 3) Completely lower the machine to the ground,
- 4) Detach top link
- 5) Remove pressure, disconnect hydraulic lines and control box (which can be totally removed from the machine if stored outside)
- 6) Detach lower lift links

Always operate with care.

6. HYDRAULIC CONNEXIONS

Follow recommendations given in the safety section of this manual. They are not restrictive.

6.1. REQUIRED HYDRAULIC REMOTES

Standard assembly

- **1 DA for turn over + automatic front furrow + Non-Stop Hydraulic safety device pressure adjustment** (independent circuit, valve shall be opened to adjust it)

In this case front furrow ram opening is set with two adjustable stoppers
there are three phases for turn over

1. front furrow ram closing
2. plough turn over
3. front furrow ram opening back

- **1 DA for hydraulic working width adjustment**

Assembly with front furrow independent hydraulic adjustment (optional)

- **1 DA for turn over**
- **1 DA for independent front furrow + Non-Stop Hydraulic safety device pressure adjustment** (independent circuit, valve shall be opened to adjust it)

In this case front furrow opening is set from the cab,
operator shall close it himself before turning the plough over

- **1 DA for hydraulic working width adjustment**

6.2. REQUIRED HYDRAULIC PRESSURE

Required tractor hydraulic pressure is 180 to 200 bars.

6.3. HYDRAULIC CONNECTIONS

- Always wipe hydraulic couplers with a clean rag on both tractor and machine sides before connecting circuits.
 - Always check for machine hydraulic connectors and tractor remotes compatibility.
 - Logically connect hydraulic lines for the user :
- ⇒ Put most frequently used functions on closest lever
- ⇒ Watch for the way hydraulic flow is delivered : pull the lever to put machine in transport position (raise up / fold), push it to put machine in working position (lower / unfold).
- ⇒ Identify hoses using colour collars and signs (+ to extend rods, - to retract them).
- Check for hydraulic hoses length : too short they may break during sharp turns, too long they may interfere with tractor lift arms or tyres.

In case of any problem, do not hesitate to contact an authorized Grégoire-Besson dealer.

7. PREPARING THE MACHINE

Follow recommendations given in the safety section of this manual. They are not restrictive.

7.1. ADJUSTING POINTS LOCALIZATION

Find adjusting points and check their lubrication and work. Doing this checking task close from a machine shop is better than doing it in the field.

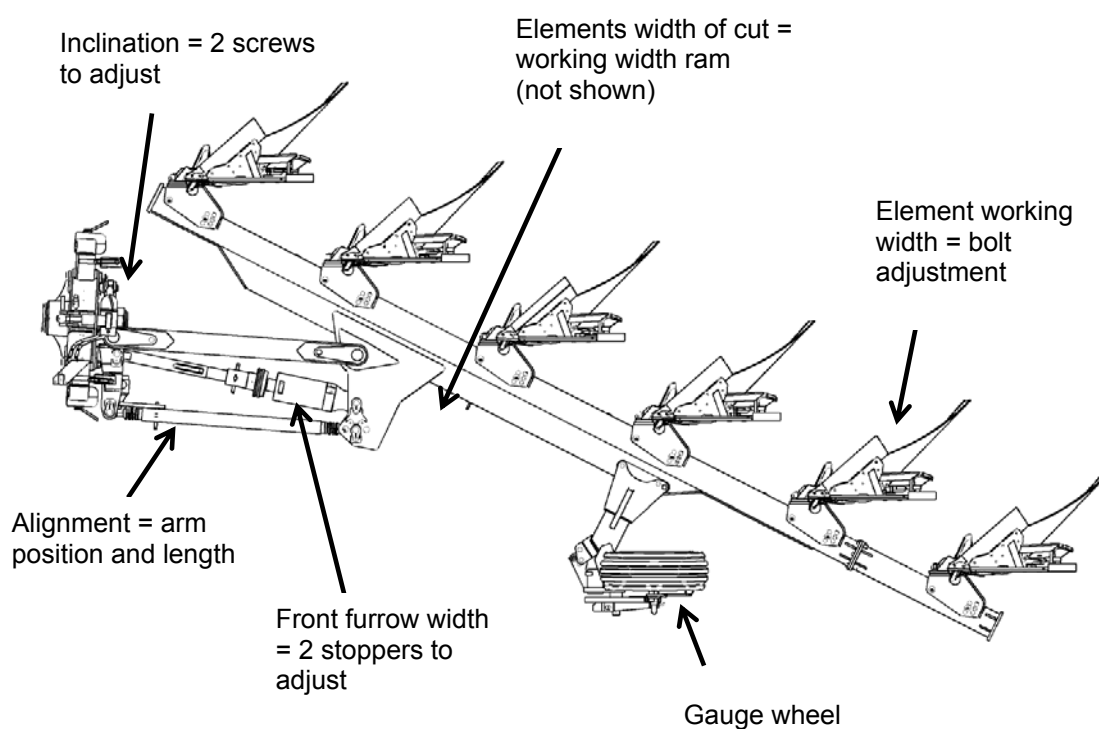

7.2. MACHINE WHEELS

7.2.1. Tyre inflation

Air pressure shall be checked every week. Do not let it drop below recommended pressure.

Tyre dimension	Recommended pressure	Maximum speed
200 x 14.5	5 bars	25 km/h
10.0 / 75 x 12	3.5 bars	25 km/h
320 x 60 - 12	2.5 bars	25 km/h

Follow tyre manufacturer recommendations (written on tyre side).



Tyre « above - inflation » = exploding risk.
Tyre « below - inflation » = rim come off risk.

7.2.2. Wheel studs

Check wheels general state and studs tightness every day.

Tread types tires may need more checking than conventional tires (more vibrations).

Always check for studs tightness before driving on public road. Tight them if necessary.

7.3. WORKING WIDTH ADJUSTMENT



Working width is adjusted by a double acting ram and an external double rod linking elements all together. On main frame an indicator allows operator to visualize adjustment.

This adjustment can be made on the go from 12" to 20".

7.4. ALIGNMENT ADJUSTMENT

7.4.1. Principle

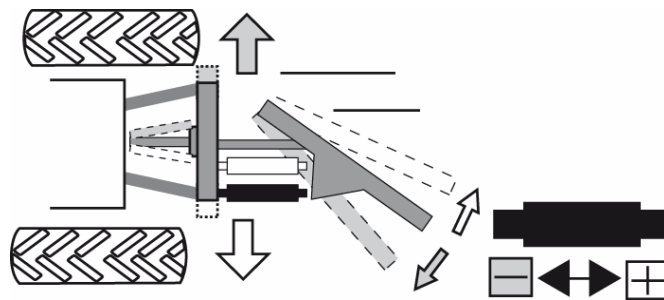

Alignment adjustment allows plough positioning behind tractor (rotation movement).

Main frame shall pivot so that traction line of both bottoms and tractor are lined up. Then useless side draft is minimum and plough steering is easy.

7.4.2. Adjustment

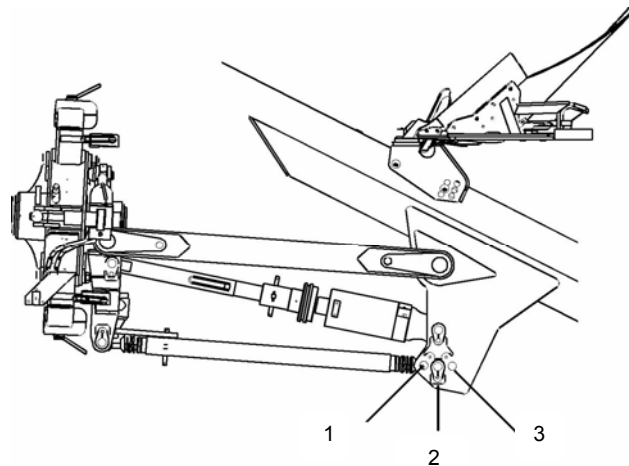

Ploughing at desired depth and width, if alignment arm is properly set, top link shall be strictly lined up behind tractor. Therefore, final adjustment shall be done in the field.

However, check for alignment pre-adjustment before beginning field operations : **alignment arm axle to axle length 1 400 mm** (for all inter body distance).

This adjustment may vary according to conditions, 1 turn = 6 mm.

7.5. FRONT FURROW ADJUSTMENT

7.5.1. Principle

Front furrow adjustment allows width adaptation of first furrow according to the others (translation movement).

All bottoms working the same width will provide an even ploughing.

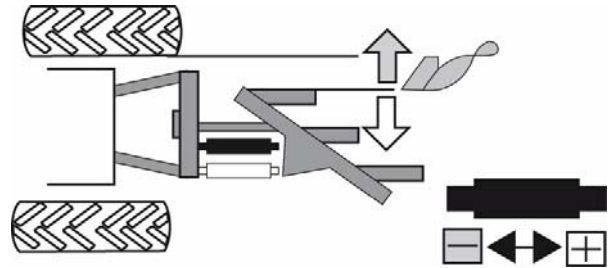

7.5.2. Adjustment

As a standard assembly, plough is equipped with two adjustable stoppers on its front furrow adjustment ram. They control ram opening in working position (front furrow width of cut) and for turn over (re-alignment).

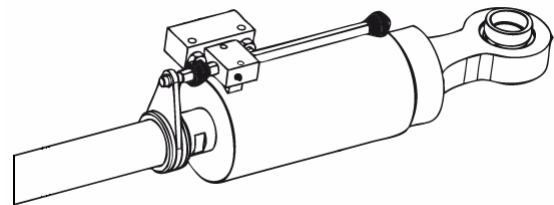

Arm axle to axle distance (ram closed) is set at the manufacture

inter body distance 900 mm = 1 325 mm

inter body distance 1 000 mm = 1 313 mm

This adjustment shall never be changed to avoid any damage on arm.

7.5.2.1. Turn over operation

There are three phases for turn over operation :

1. machine alignment behind tractor
2. machine turn over
3. machine coming back in its working position

Stoppers adjustment for plough re-alignment during turn over manoeuvre

Plough shall be properly balanced :

- make sure plough is properly attached to the tractor
- start turn over operation
- once machine has turned 135°, put hydraulic control lever on float position = neutral
- a properly balanced machine reaches its working position by its own weight
- if movement is stopped or if machine reaches its position with a shock, it is not correctly balanced = stoppers adjustment shall be changed
- once stoppers are properly set, make sure gauge wheel does not touch the ground during operation, if so stoppers adjustment shall be modified again.

Note : when plough has turned 90°, it is in transport position. A 135° turn is reached when machine has done half of its dropping to working position.

7.5.2.2. Field operation

On land ploughing (refer to picture on section 4.2.2.1.)

- Front adjuster shall be opened wide enough so that 1st furrow cuts the same width as the others, tractor running on land. A minimal distance shall be let between furrow wall and external side of rear tyre or track (at least 15 cm).
- Then operator shall drive so that ploughing is even.

In the furrow ploughing (refer to picture on section 4.2.2.2.)

- Set front adjuster so that 1st bottom cuts the same width as the others, tractor running in the furrow.

7.6. PREPARING PLOUGH BOTTOMS

Grégoire-Besson plough bottoms are protected before leaving the factory to prevent rusting. Good field work cannot be accomplished until this coating is removed : mouldboards do not shine, ground is stuck to the steel.

If necessary, use a solvent, such as paint remover to take the protective black paint off.



CAUTION : keep work area well ventilated when using solvent such as paint remover to remove protective paint. Wear eye and hand protection.

7.7. NON-STOP HYDRAULIC SAFETY DEVICE PRESSURE ADJUSTMENT

Plough is equipped with a 100 bars accumulator. For regular working conditions, pressure in non-stop hydraulic safety device shall be set between **110 and 150 bars**, which corresponds to the green zone on the gauge. **Always stay in this range.**

Adjustment procedure :

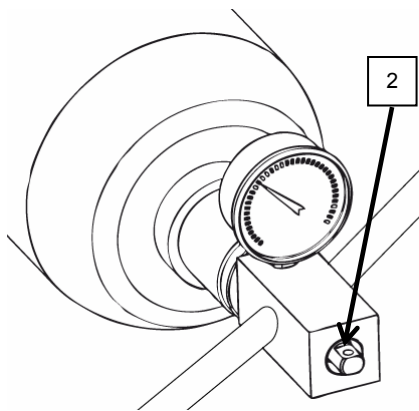

- Non-stop safety device is linked to hydraulic front furrow width adjustment
- Open set screw (2) on accumulator situated on external fixed arm of parallelogram.
- To **increase NSH safety device resistance**, increase hydraulic pressure in the system, **adding oil** acting on hydraulic control lever.
- To **decrease NSH safety device resistance**, decrease hydraulic pressure in the system, **removing oil** acting on hydraulic control lever.
- Once desired pressure is reached, close set screw (2). NSH safety device circuit is now independent from hydraulic front furrow width adjustment.

Clever way for an operator alone in the field :

- Open valve (2) and add more pressure than required in the circuit. Shut valve (2).
- In tractor's cab, put hydraulic control lever on "Float position".
- Slightly open valve (2) so that oil slowly goes back to tractor.
- Once desired pressure is reached, close valve (2). Then hydraulic hose (1) may be disconnected.

7.12. RJL = LATERAL DEPTH WHEEL

RJL is a depth wheel laterally positioned.

As an option, a transport kit allows its using as a transport wheel.

7.12.1. Working position

Depth control adjustment is done positioning pin (1).

To change ploughing depth :

- remove safety clip and pin (1)
- to increase working depth, raise the wheel
- to decrease working depth, lower the wheel
- insert pin (1) in the appropriate hole and install back safety clip

For a more precise adjustment, set length of both screws (3).

- loose jam nuts (2)
- set length of screw (3)
- tight back jam nuts (2).

This adjustment is independent R.H. and L.H.

Wheel alignment adjustment : wheel shall run lined up with elements

- plough with mechanical bolt adjustable width : wheel alignment is done positioning bolt (5). The angle between wheel and frame shall be the same as the angle between elements and frame. This adjustment is done at the manufacture, it shall be changed if machine working width is changed
- plough with hydraulic variable width : wheel mounting bracket is linked to variable width device so that wheel stays lined up with elements.

7.12.2. Transport position

As an option, a transport arm (6) is available to turn RJL into a transport wheel. It is set at the rear of the machine.

Turning wheel into transport position :

- raise machine, remove clip (4) then remove wheel from its working arm
- pivot plough 90°
- install wheel on its transport arm (6), do not forget its safety clip
- put machine in transport position (refer to section 8)

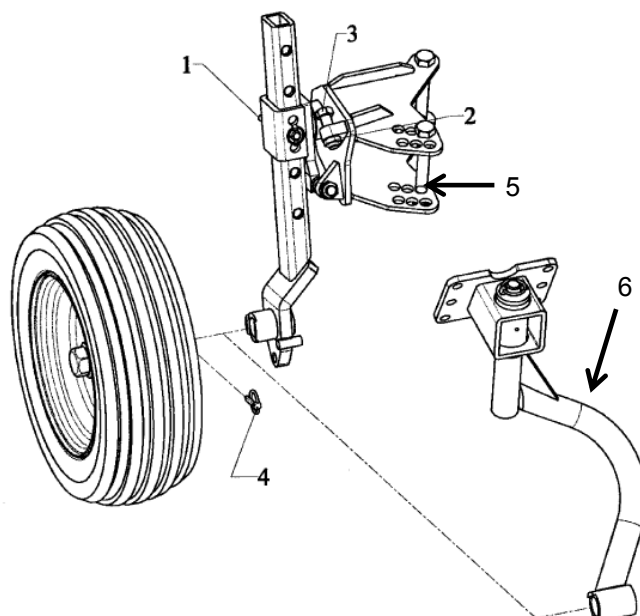

7.13. RJR = REINFORCED DEPTH WHEEL

RJR is a depth wheel rear positioned.

As an option, a transport kit allows its using as a transport wheel.

7.13.1. Working position

Adjusting depth control :

- to increase working depth, screw the two adjusters (1),
- to decrease working depth, unscrew the two adjusters (1).

Adjusting wheel alignment :

- plough with mechanical bolt adjustable width
 - loose both jam nuts (4)
 - set wheel parallel with elements
 - tight back both jam nuts (4)
- plough with hydraulic variable width : wheel mounting bracket is linked to variable width device so that wheel stays lined up with elements.

7.13.2. Transport position

As an option, a transport arm (2) is available to turn RJR into a transport wheel.

Turning wheel into transport position :

- install transport arm (2) on mounting bracket (3), do not forget the safety clip
- raise machine, remove clip, then remove wheel from its working arm
- turn plough over 90°
- insert wheel on the transport arm (2), do not forget its safety clip
- put machine in transport position (refer to section 8)

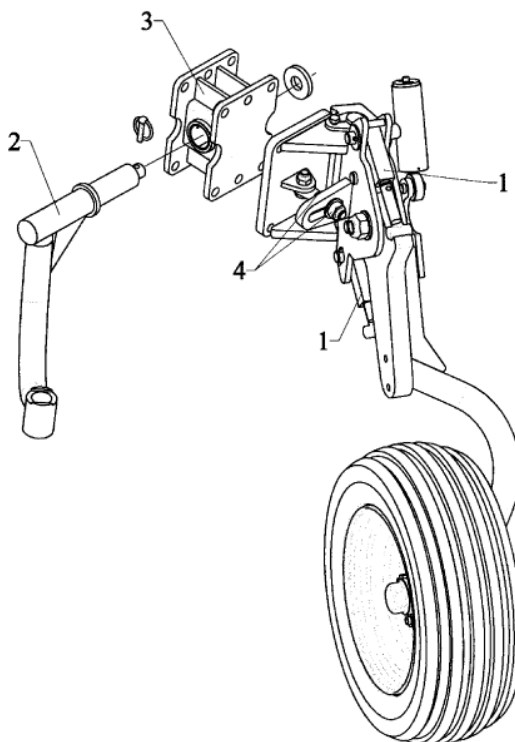

7.15. DRL20 = LATERAL DUO WHEEL

DRL20 is a combined wheel used for depth control and transport (carriage position). It is laterally positioned.

7.15.1. Working position

Turning wheel in working position :

- put plough in working position (R.H or L.H. side)
- insert stopper (4) into shock absorbers articulation (3)
- install safety clip to prevent any unforeseen movement of stopper (4)
- turn both wheels in working position = pivot them 90°, lock them with pins and safety clips
- put pin (5) in the hole corresponding to the slot = DRL20 shall line up with elements.

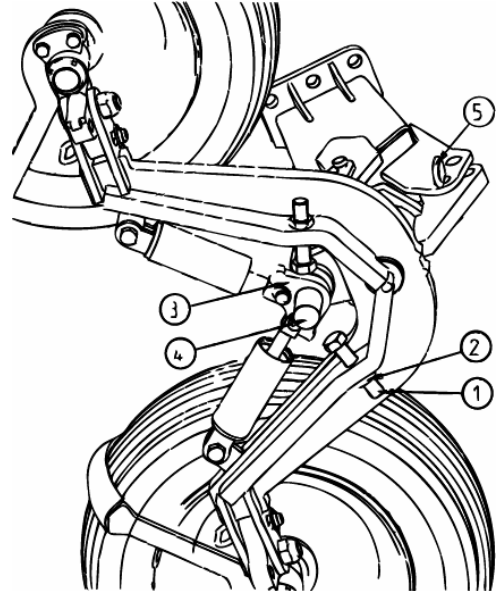

Ploughing depth adjustment :

- loose jam nuts (2)
- to increase working depth, screw bolts (1)
- to decrease working depth, unscrew bolts (1)
- tight back jam nuts (2)

7.15.2. Transport position

Turning wheel in transport position :

- put plough in working position (R.H or L.H. side)
- stopper (4) shall release shock absorbers articulation (3) = DRL20 shall follow tractor running in curves
- install safety clip to prevent from any unforeseen movement
- turn both wheels in transport position = pivot them 90°, lock them with pins and safety clips
- put pin (5) in the fixed hole
- put machine in transport position (refer to section 8)



Maximal speed for road transport is limited to 25 km/h.

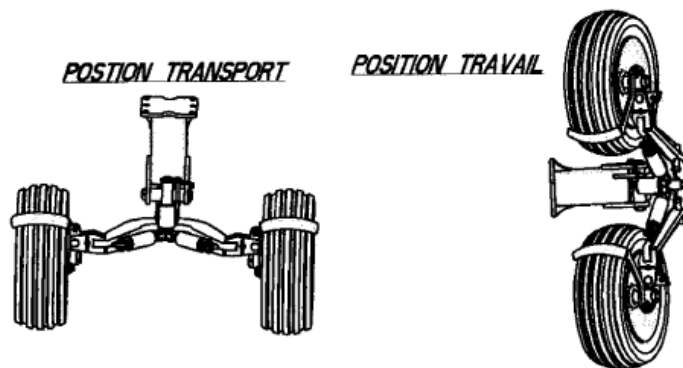

7.15.3. Working depth adjustment range

There are three arms available for DRL20 :

- short : wheels pivot points axle to axle distance L = 710 mm, ref. 199 047, standard for point to point distance 160 cm
- medium : wheels pivot points axle to axle distance L = 810 mm, ref. 199 048, standard for point to point distance 170 cm
- long : wheels pivot points axle to axle distance L = 910 mm, ref. 199 049, standard for point to point distance 180 cm

Refer to the chart here after to know the depth adjustment range (X) according to the arm. Working depth given in mm according to point to point height, type of tyre and arm.

In brackets the minimal working depth reached with jam nut positioned on depth adjustment screw head side.

Contact and authorized Grégoire-Besson dealer for any further information.

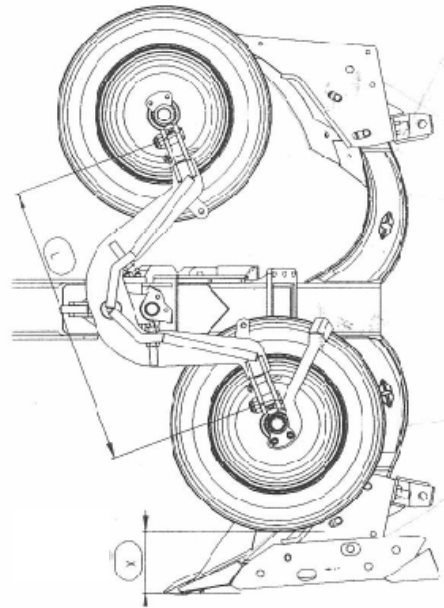

Height	160 cm				170 cm				180 cm			
	200 x 14.5		10.0-75x12		200 x 14.5		10.0-75x12		200 x 14.5		10.0-75x12	
Tyre	Min	Max	Min	Max	Min	Max	Min	Max	Min	Max	Min	Max
Arm 710 mm	116 (65)	335	81 (30)	300	166 (115)	385	131 (80)	350	<u>Not available</u>			
Arm 810 mm	53 (21)	295	18 (0)	260	103 (71)	345	68 (36)	310	153 (121)	395	118 (86)	360
Arm 910 mm	<u>Not available</u>				53 (21)	304	18 (0)	269	103 (71)	354	68	319

7.16. RTRH AND RCRH = HYDRAULIC DEPTH WHEEL WITH REALIGNMENT = HYDRAULIC COMBINED WHEEL WITH REALIGNMENT

Both RTRH and RCRH have automatic hydraulic realignment for turn over. There are lateral positioned wheels. RTRH is exclusively depth wheel. RCRH is a combined wheel which can be used for depth control and road transport.

7.16.1. Hydraulic realignment principle

Wheel's hydraulic memory ram is linked with plough's alignment arm (whether variable width ram, automatic hydraulic alignment arm, automatic hydraulic front furrow width arm). This way, wheel is automatically lined up with main frame for each turn over sequence.

Turn over sequence description

First phase : plough is automatically centred behind tractor : wheel is brought parallel with main frame by its memory ram, automatic hydraulic arm lines up main frame and tractor

Second phase : turn over ram rolls the plough over

Third phase : plough automatically comes back top its previously adjusted working position : wheel is brought back to its working position by the memory ram, automatic hydraulic arm also return to its desired working position

Note : thanks to its memory ram, wheel always come back to its initially set position to keep constant ploughing depth.

Important : when using the wheel for the first time, purge hydraulic circuit to chase air away.

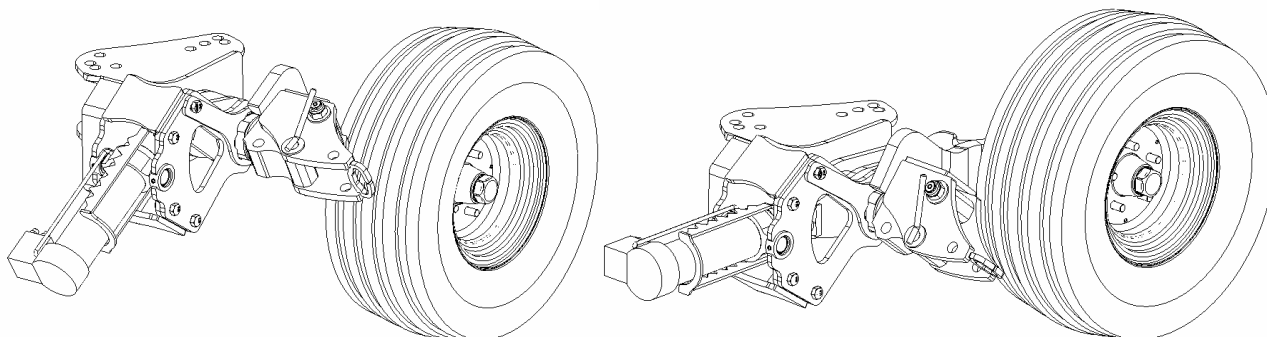

Improvements and advantages of this wheel

Smooth turn over manoeuvre : no shocks at side changing, since wheel is held in position by the memory ram

Gentle entering into the ground : no more shocks or solicitations on gauge wheel when lowering the machine since ram prevents from wheel falling towards. This ensures both wheel and frame long lasting.

7.16.2. Assembly possibilities

Both wheels RTRH and RCRH are compatible on 4, 4+1, 5 and 5+1 bottoms on ranges R47, RW47, R71, R7, RW7, HRP7, HRPW7. Plough must absolutely be equipped with an automatic valve (RA6 or RA6-2M).

Available tyres :

- for RTRH : 200 x 14.5, 10.0 / 75 x 12, 320 / 60 - 12
- for RCRH : 200 x 14.5, 10.0 / 75 x 12, 320 / 60 - 12

7.16.3. Changing from working to transport position (RCRH)

Changing from working to transport position is an operation fast and easy :

- remove pin
- pivot $\frac{1}{4}$ turn wheel mounting bracket
- insert pin.

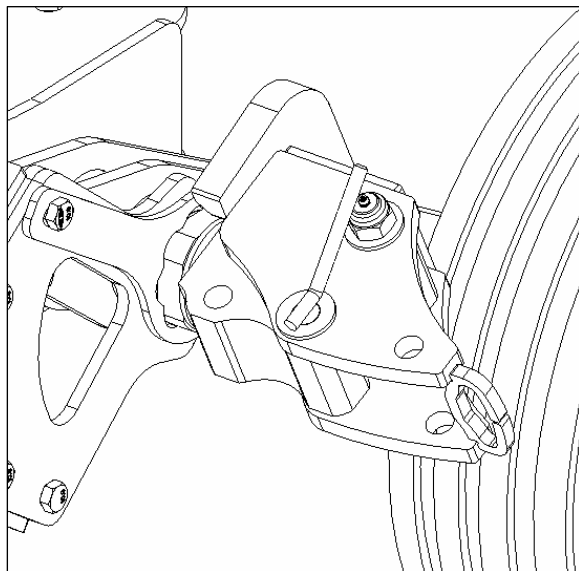

Wheel in working position

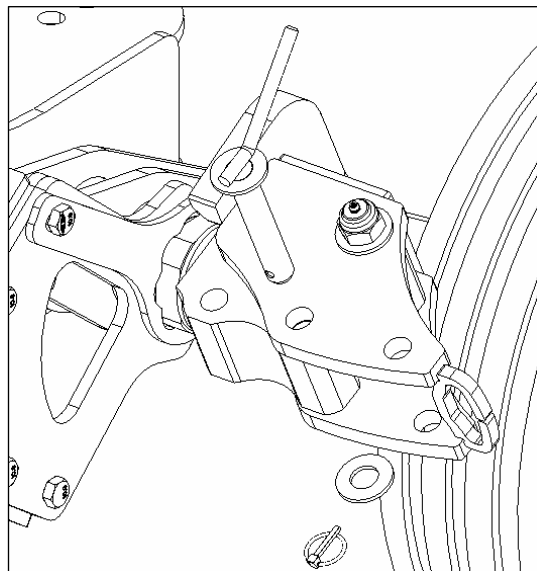

Remove safety clip and pin

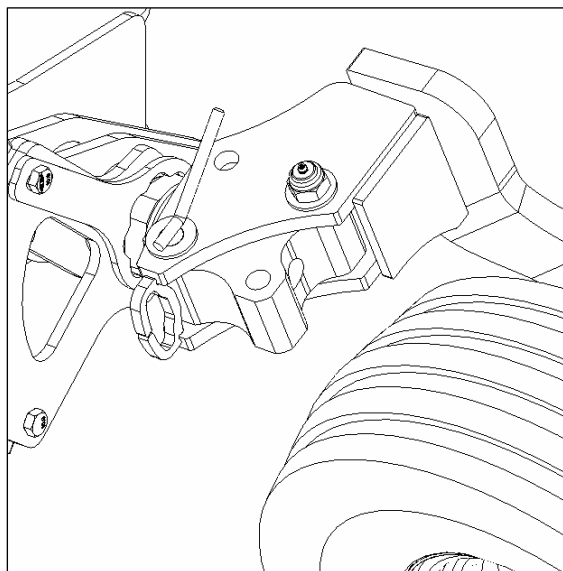

Pivot wheel mounting $\frac{1}{4}$ turn
install back safety clip and pin

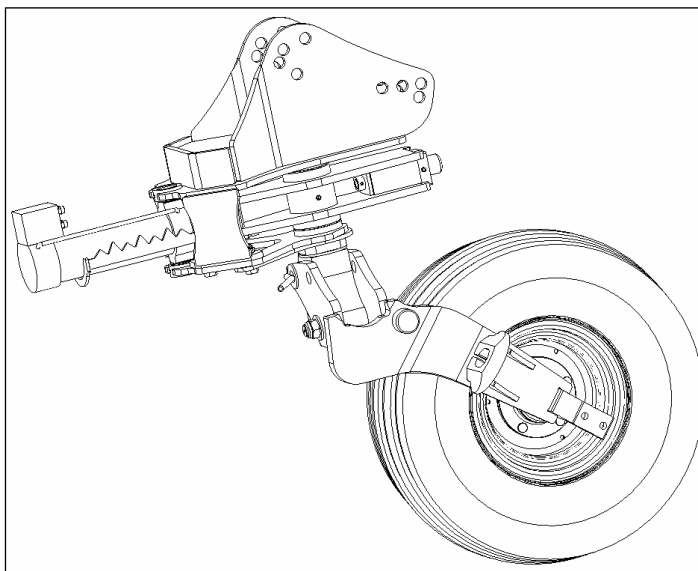

Wheel in transport position

Follow this procedure the opposite way to change wheel from transport to working position.

7.16.4. Automatic engaging after changing to working position (RCRH)

After changing from transport to working position, no need to lift the wheel to engage mounting bracket.

Wheel is automatically engaged at first lowering machine to the ground : mounting bracket raises till stopper comes into its position (refer to drawings). Then plough comes back to the working depth set before transport.

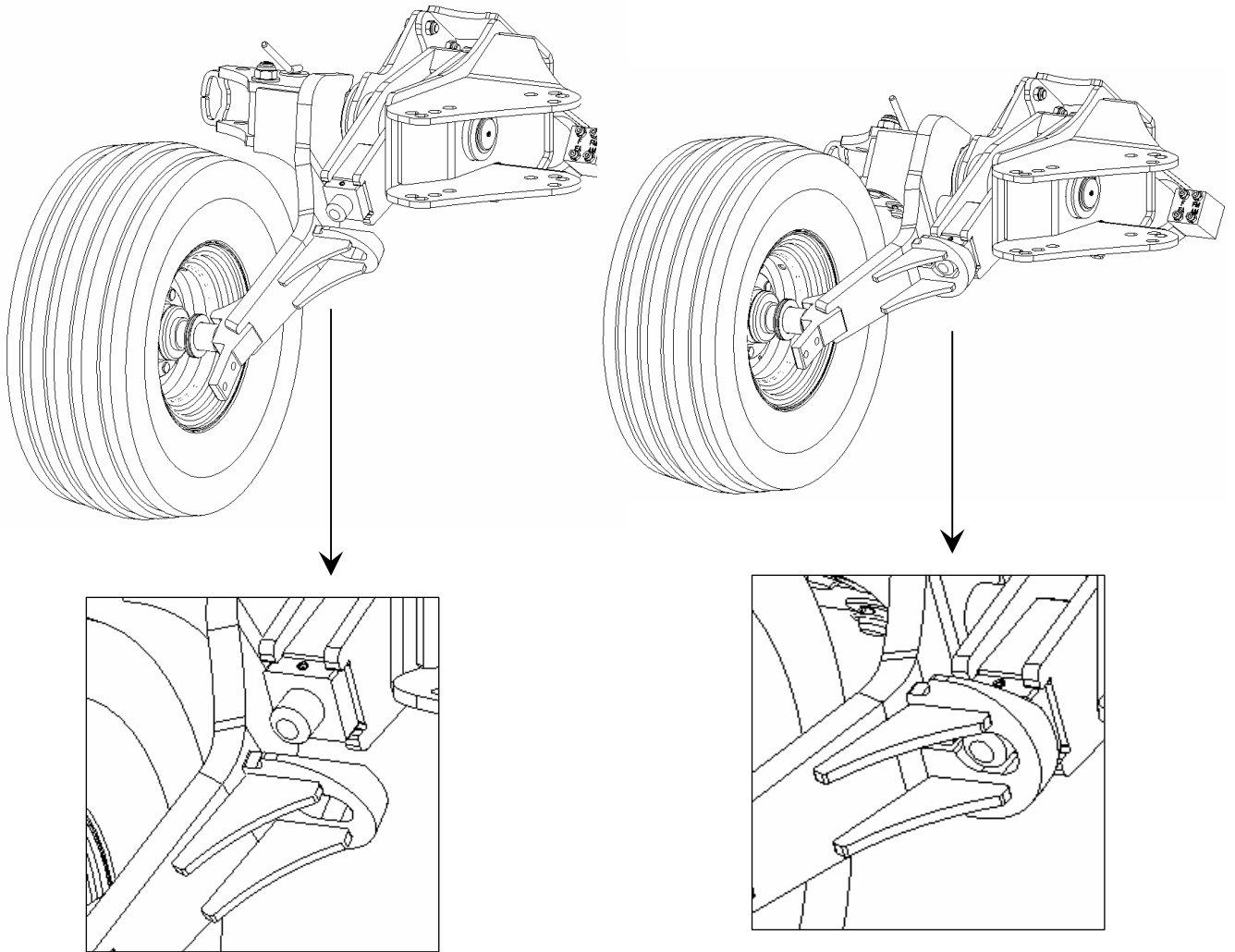

During this manoeuvre, a specially design stopper prevents from wheel falling towards.

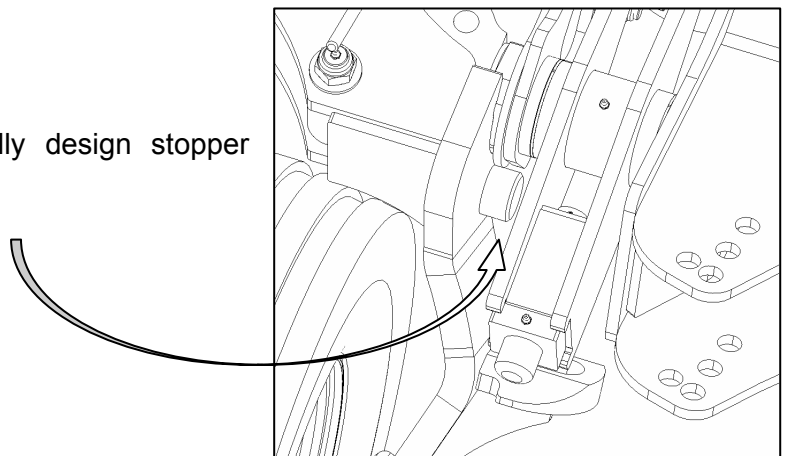

7.16.5. Adjusting working depth

Working depth is set using an independent DA remote.

It can be adjusted "on the go" using control lever from the cab.

Plough can be completely raised if required (rocky spot, white soil close to surface, ...).

Then it can be brought back to its previously set position readable on indicator.

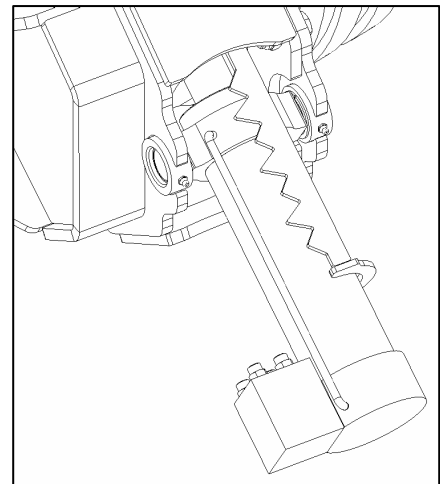

7.16.6. Positioning wheel support bracket according to working width

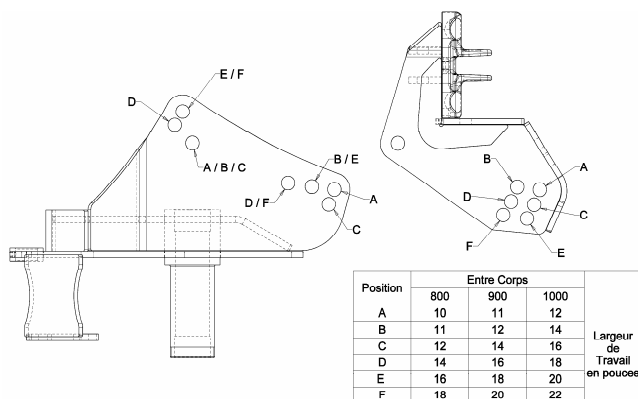

On ranges R4 - R41 - R47

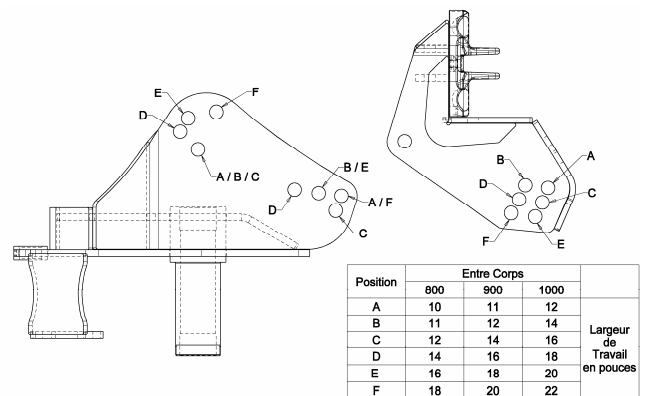

On ranges R7 - R71

7.16.7. Hydraulic connexions

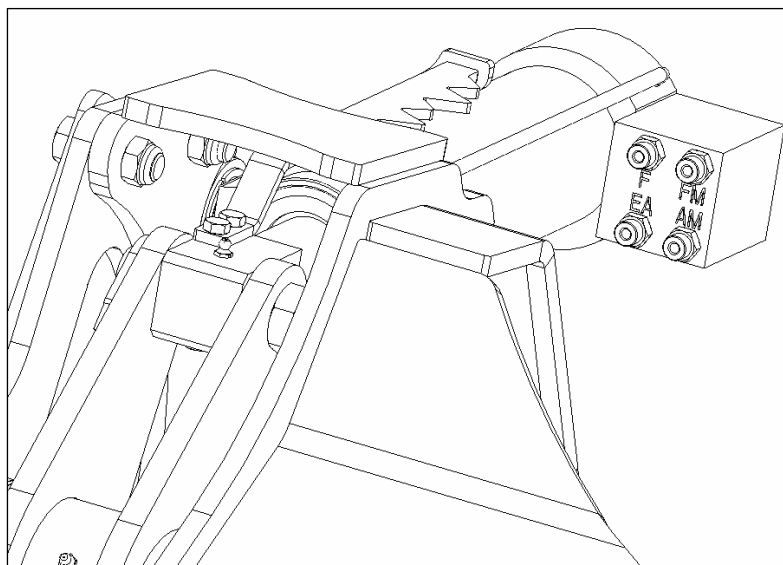

7.16.7.1. Plough equipped with an automatic hydraulic alignment arm

- Outlets F and EA connected direct to tractor for ploughing depth control.
- Outlets FM and AM connected to automatic alignment ram.
 - Outlet AM on wheel ram connected to outlet A on alignment ram.
 - Outlet FM on wheel ram connected to outlet B on alignment ram.

7.16.7.2. Plough equipped with an automatic hydraulic front furrow width arm

- Outlets F and EA connected direct to tractor for ploughing depth control.
- Outlets FM and AM connected to hydraulic front furrow width arm.
 - Outlet AM on wheel ram connected to outlet B on front furrow width ram.
 - Outlet FM on wheel ram connected to outlet A on front furrow width ram.

7.16.7.3. Plough equipped with a memory ram for hydraulic variable width adjustment

- Outlets F and EA connected direct to tractor for ploughing depth control.
- Outlets FM and AM connected to hydraulic variable width memory ram.
 - Outlet AM on wheel ram connected to outlet A on variable width memory ram.
 - Outlet FM on wheel ram connected to outlet B on variable width memory ram.

NOTES

8. TRANSPORTING

Follow recommendations given in the safety section of this manual. They are not restrictive.

8.1. CHANGING TO TRANSPORT POSITION

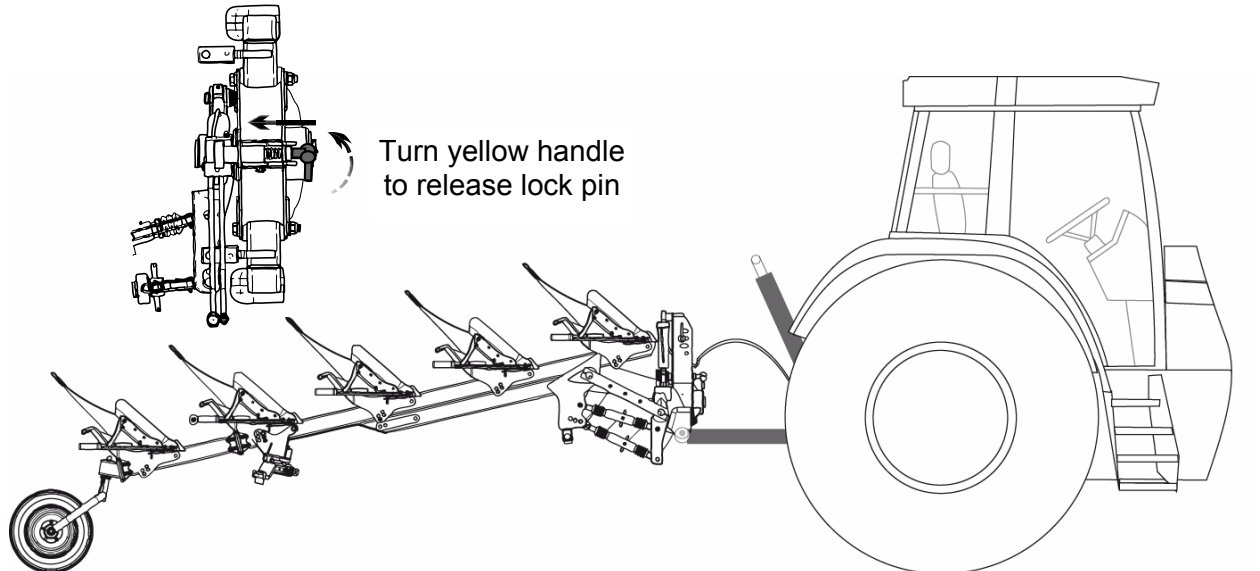

Before driving on a public road, put machine in transport position :

- **Lower the machine to the ground in working position** : it shall stand on its elements
- **Put wheel in transport position** : refer to wheel section (shall not apply for machines equipped with depth wheel only)
- **Install lock pin** : install transport safety lock pin turning yellow handle. Lubricate spring if pin is hard to move
- **Raise the machine and start turn over manoeuvre** : plough lines up and automatically locks in transport position
- For machines equipped with a transport wheel :
 - lower the machine** so that wheel touches the ground
 - detach top link**
- **Lower tractor hydraulic hitch** : to lower machine centre of gravity, improving its stability in transport
- **In the cab lock all control levers** : lock all control levers (hydraulic remotes, hitch, ...) to avoid any unforeseen movement, and potential accident.
- If tractor is equipped with a stabilizers locking system, install it to prevent any useless movement.
- **Install all lights, reflectors and signs required by current applicable law.**

8.2. CHANGING TO WORKING POSITION

To put machine in working position, follow here above described procedure in the opposite way.

Make sure top link is correctly connected to the machine before removing transport locking pin.

8.3. DRIVING ON PUBLIC ROAD

Before driving on a public road :

- **Be sure all signs, reflectors and lights required by local current law are in place, clean and visible to traffic.**
- Make sure there are no interferences between tractor and machine.
- Adopt a gentle attitude towards other public road users.

On public road, comply with local applicable laws :

- Tractor required for road transport shall equal the size and the horse power rating of the tractor used to work in the field.
- Do not drive over 25 km/h (= 15 mph).
- Drive at a reasonable speed to maintain complete control of both tractor and machine.
- Reduce speed on corners and on rough grounds.
- Do not drive down a hill faster than it could be possible to drive it up.
- Do not apply the tractor brakes to attempt a sharp turn.
- Always check wheel studs tightness before driving on a public road. They may get loose because of vibrations.
- Respect authorized maximum size for transport load (width, weight, length). For over sized loads, comply with current law taking all necessary precautions (signs, lights, escort, authorizations, ...).
- Respect the maximum wheel axle load and the maximum total driving load. Make sure front axle carries at least 20% of tractor's tare. Use front end weights if necessary.

ATTENTION : driving on public roads, operator is responsible for both tractor and equipment. He has to comply with current applicable law (getting in conformity with it and following its evolutions).

9. FIELD ADJSUTMENT

Follow recommendations given in the safety section of this manual. They are not restrictive.

9.1. FIELD UTILIZATION

Put machine in working position (refer to previous section).

To reach a decent ploughing, operating speed shall be between 6 and 8 km / h (= 3.7 to 5 mph). Higher speed may lead to over wearing of wearing parts.

Always lift up machine before manoeuvring or turning on headlands.

Never attempt a sharp turn with the machine in the ground.

Reduce speed before manoeuvring or crossing obstacles (ditch, ridge, rocky spots, ...).

As long as possible, regularly change field opening side to avoid rolling ground always the same way. This could result in creating a ridge on one side of the field and a ditch on the other side.

Several up and down passes might be necessary before reaching an optimum ploughing, moreover with a new plough or at the beginning of a new season. During each pass, mouldboards get more polished, soil flow gets better and adjustments can be improved.

IMPORTANT : before beginning field utilization, entirely read this chapter to understand all adjustments, their order and procedure.

IMPORTANT : always do one adjustment at a time. Then it is easier to check its performance and to change it if necessary.

9.2. FIRST PASS

First pass differs from the others since tractor is furrow to fill. This interferes with several adjustments : inclination and front furrow (width and depth).

9.2.1. Entering into the ground

Adjust working width. Refer to section 7.3.

Drive slowly and lower the machine to have a smooth entering into the ground.

9.2.2. Alignment adjustment

This is the first adjustment to do ploughing with a fully mounted reversible plough. Stabilizers shall be free (2 to 5 cm loose).

- **Top link** shall be **strictly lined up** behind tractor.
- If **top link** looks **towards ploughed ground**, plough shall be lined up with tractor traction line **shortening alignment arm**.
- If **top link** looks **towards non ploughed ground**, plough shall be lined up with tractor traction line **extending alignment arm**.

9.2.3. Ploughing depth adjustment

Ploughing depth is controlled by :

- tractor hydraulic hitch height for the front end of the plough,
- gauge wheel height for the rear end of the plough.

9.2.3.1. Tractor hydraulic hitch height adjustment

Tractor hitch height is controlled from the cab. For the first pass first bottom cannot fill any furrow with ground. So set hitch height so that there is no formation of an excessive ridge.

9.2.3.2. Tractor draft control adjustment

To begin, set draft control on a minimum sensibility. Therefore front furrow depth will be easier to check and / or to adjust.

Later on, once plough is properly adjusted, draft control sensibility may be increased to improve tractor's adhesion.

Note : in bad conditions (wet fields, low horse power reserve, ...) it is impossible to work with minimum draft control. Hitch reactions to the load shall then be taken in account for average front furrow working depth estimation.

9.2.3.3. Gauge wheel height adjustment

Gauge wheel height may be approximately adjusted during first pass. Checking and / or readjustments will be done on the following passes.

- To increase working depth, raise the wheel
- To decrease working depth, lower the wheel

Refer to gauge wheel section.

9.2.4. Side to side levelling = inclination adjustment

Set elements perpendicular with the ground (better penetration, easier pulling, ...). Refer to section 9.3.3.

9.2.5. Front furrow width adjustment

Set front furrow maximum offset from the tractor to plough as close as possible from the fence. Refer to section 9.3.4.

9.3 SECOND PASS

Before any final adjustment, make sure mouldboards are scoured. Ground shall slide along steel and never stick. In heavy conditions, removing bolted points for the first working hours might help scouring mouldboards. Do not hesitate to contact an authorized Grégoire-Besson dealer in case of problem.

9.3.1. Alignment adjustment

Check for good alignment adjustment. Plough shall be properly lined up behind tractor, top link strict. Landsides shall slide along furrow wall, without excessive pressure.

9.3.2. Front to rear levelling

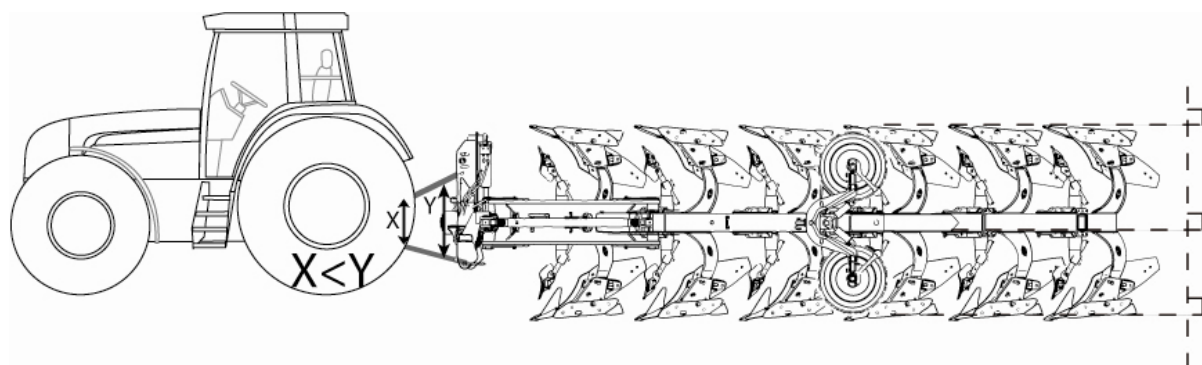

Once tractor runs in the furrow, plough has to be levelled from front to rear so that all bottoms work at the same depth (refer to picture).

Adjustment procedure

- For the desired ploughing depth, find the right balance between tractor hydraulic hitch height, gauge wheel height and top link length.
- **Top link position** : at work, top link shall always be positioned higher on machine side than on tractor side. This will allow a good weight transfer on front axle. Refer to picture, $X < Y$. Change top link fixing on tractor if necessary.
- **Top link length** : top link length shall be adjusted so that working at desired depth top link pin stays free to move in the slot.
- Any modification of ploughing depth (wheel height) leads to tractor hitch and top link length modification.

9.3.3. Side to side levelling

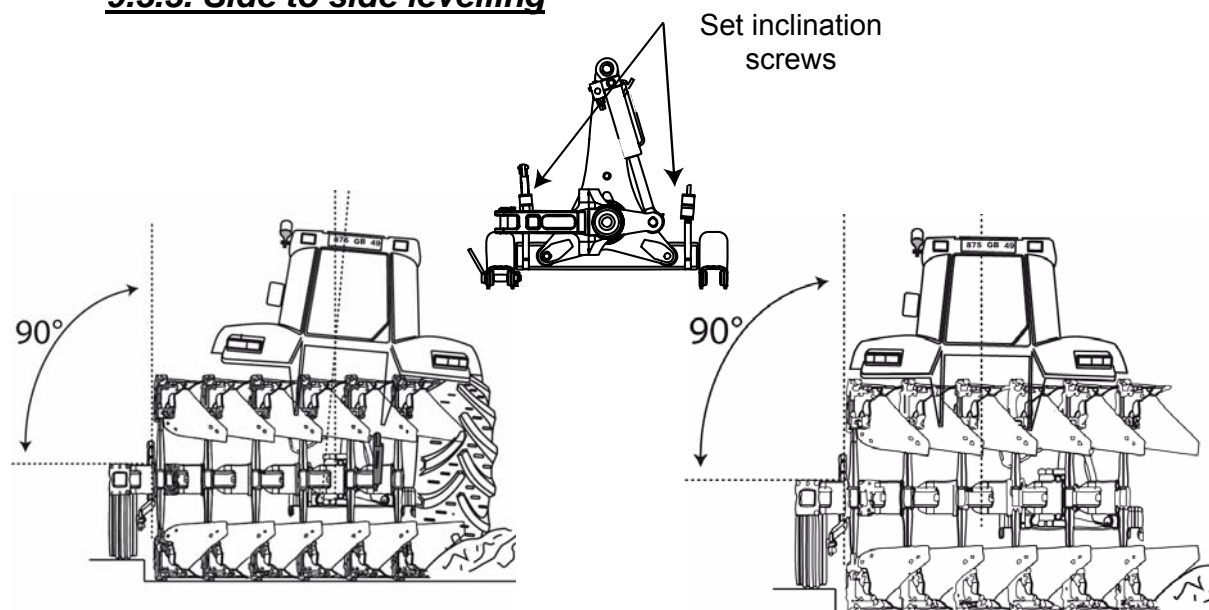

Plough shall be levelled laterally (= from side to side). Elements shall work perpendicular with the ground. Refer to picture.

In specific conditions (sloping fields, heavy clay, ...) plough may be slightly tilted towards ploughed ground to increase mouldboard action on the soil.

Adjustment procedure

- Raise plough out if the ground
- Act on control lever, start turning the plough to remove pressure from inclination screw
- Adjust inclination screw length
- Put machine back in working position, plough a short distance and check adjustment performance
- Start adjustment again if necessary.

Note : inclination adjustment is independent R.H. and L.H.

Note : for in the furrow ploughing, final adjustment shall be done once tractor runs in the furrow at desired depth.

9.3.4. Front furrow width adjustment

9.3.4.1. If tractor is on land = on land ploughing

On front furrow adjustment ram, stoppers shall be set so that 1st bottom is far enough. Refer to sections 4.2.2.1. and 7.5.

Then it is driver's job to guide tractor making sure ploughing is even.

9.3.4.2. If tractor is in the furrow = in the furrow ploughing

Front furrow width adjustment shall be done once plough is correctly lined up both front to rear and side to side. On front furrow adjustment ram, stoppers shall be set so that 1st cuts the same width as the others. Refer to sections 4.2.2.2. and 7.5.

- **If front furrow leaves a ridge**, it ploughs too much ground. **Its width shall be reduced shortening front furrow arm.**
- **If front furrow leaves a hole**, it does not plough enough ground. **Its width shall be increased extending front furrow arm.**
- **Particular case :** => if front furrow ploughs excessive width, a hole may appear : mouldboard is so far from its theoretical position that it cannot bring ground far enough to fill the furrow,
=> working on sloping fields, it may be necessary to re-adjust front furrow width for each pass to leave a really levelled surface

9.4. SAFETY DEVICE ADJUSTMENT

9.4.1. Shear bolt safety device type « B »

In case of safety bolt shearing :

- Put plough in transport position, elements shall be horizontal to replace bolts without crushing risks.
- Pivot element to line up holes.
- Install new safety bolt.



IMPORTANT : respect safety bolts specifications. Only use certified genuine Grégoire-Besson spare parts.

9.4.2. Non-Stop Hydraulic safety device type « Y » or « Z »

In case of excessive tripping

Ploughing is not even.

Pressure shall be increased in the circuit. Refer to section 7.7.



CAUTION : always stay in the green zone on the gauge. If maximum pressure is not high enough, contact an authorized Grégoire-Besson dealer. Larger diameter safety rams may be required.

In case of insufficient tripping

Bottoms hit rocks and bring them up. There is a risk for wearing and / or structure parts breaking. Useless pressures may damage the plough and affect its life time.

Pressure shall be reduced in the circuit. Refer to section 7.7.



CAUTION : never reduce too much the pressure in the circuit. Elements could fall down and cause severe injury or death by crushing.

9.5. SKIMMER ADJUSTMENT

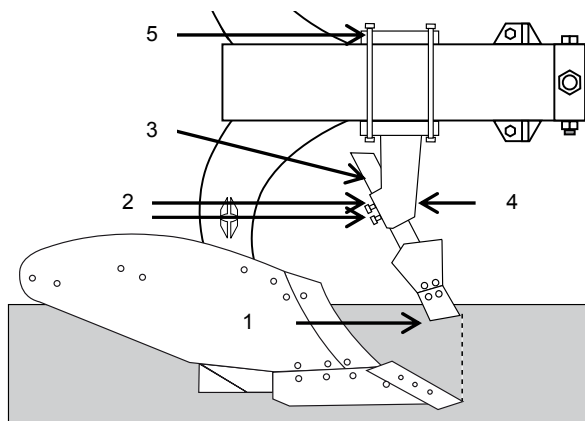

Skimmers provide good trash coverage. They are protected by a shear bolt safety device

Grégoire-Besson skimmers have been specially designed to be adjustable by an operator alone in the field.

9.5.1. Shear bolt safety device

Each skimmer is protected by a shear bolt. When hitting an obstacle, this bolt would break for skimmer to raise up.

In case of bolt shearing

- Remove all broken parts
- Install a new safety bolt

=> standard : screw ref. VI 29 08, H M12x45, grade 8.8 + nut ref. VJ 322.

=> reinforced : screw ref. VI 29 09, H M12x45, grade 10.9 + nut ref. VJ 322.

9.5.2. Skimmer height adjustment

In general, skimmer share (1) should work the ground for half of its height to be efficient (refer to picture).

Guideline for adjustment

- Skimmer height adjustment is linked to ploughing depth, so it shall be checked after each ploughing depth changing.
- If skimmer is set too high : there is a plugging risk behind it, if there is still too much residue on the surface.
- If skimmer is set too low : there is a plugging risk ahead it, if there is too much material coming in. In this case, plough is hard to pull.

=> Both situations lead to poor trash coverage.

Adjustment procedure

- Loose the two pointed screws (2).
- Move skimmer arm (3) through its mounting bracket (4) to reach the desired height.
- Tight both pointed screws (2) inside marks of arm (3).
- In a first time, adjust 1 or 2 skimmers and make a try. If it is better, then adjust all other skimmers. If not, go back and try another adjustment.
- **All skimmers shall be set the same on both sides so that plough works evenly.**
- Special long arms (3) for shallow ploughing are available. Contact an authorized Grégoire-Besson dealer.

9.5.3. Skimmer front to rear adjustment

In general, skimmers are pre-adjusted at the manufacture for its share to be lined up with bottom's point (refer to picture on previous page).

Guideline for adjustment

- If skimmer is ahead from the point, crop residue is ploughed down in the furrow.
- If skimmer is behind the point, crop residue is ploughed higher in the furrow.
- In heavy trash conditions, it might be necessary to set skimmer behind the point.

Adjustment procedure

- Loose the four carriage bolts (5).
- Move skimmer mounting bracket (4) to the desired position.
- Tight all four carriage bolts (5).
- In a first time, adjust 1 or 2 skimmers and make a try. If it is better, then adjust all other skimmers. If not, go back and try another adjustment.
- **All skimmers shall be set the same on both sides so that plough works evenly.**

9.6. BOTTOM PITCH ADJUSTMENT

$$Y = X - 15 \text{ mm}$$

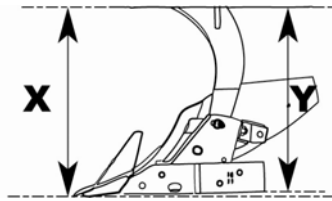

Grégoire-Besson bottom's pitch is adjustable. At the manufacture, it is set so that in working conditions front part (point) is 15 mm lower than rear part (end of landside). This adjustment is adapted to most ploughing conditions.

Before any modification of standard adjustments

Check wearing parts general state

Wearing parts worn out may lead to poor ploughing and / or poor penetration.

Think ahead for possible consequences

Pitch augmentation	better penetration (specially in dry grounds) plough harder to pull (more fuel consumption) excessive pressure on safety device stone climbing
Pitch reduction	ground escaping underneath mouldboard opposite effects poor penetration

FOR ALL CONDITIONS NEVER HAVE X < Y

Adjustment procedure

- Remove dirt from all bolts, nuts and threads.
- Remove wear plate (45) to reach bolt (41).
- Loose bolts (41) and (42), and both jam nuts (43) located on eye bolt (44).
- To increase the pitch, screw rear nut (43) on eye bolt (44).
- To decrease the pitch, unscrew front nut (43) on eye bolt (44).
- Once desired pitch is set, tight all bolts and install back wear plate (45).
- **All bottoms on both sides shall have the same pitch for the plough to work evenly.**

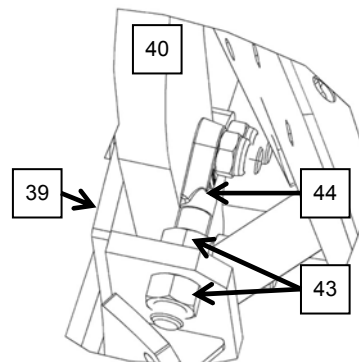
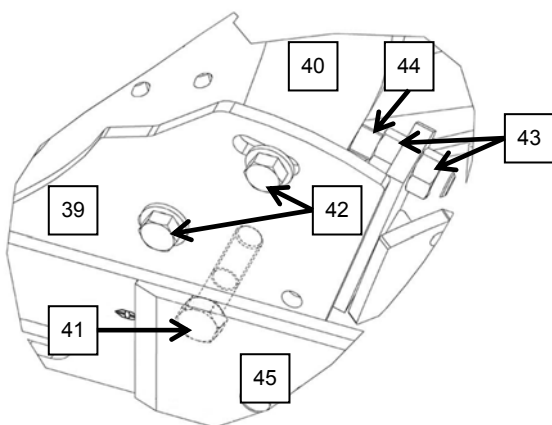

9.7. CCR 99 DISC COULTER ADJUSTMENT

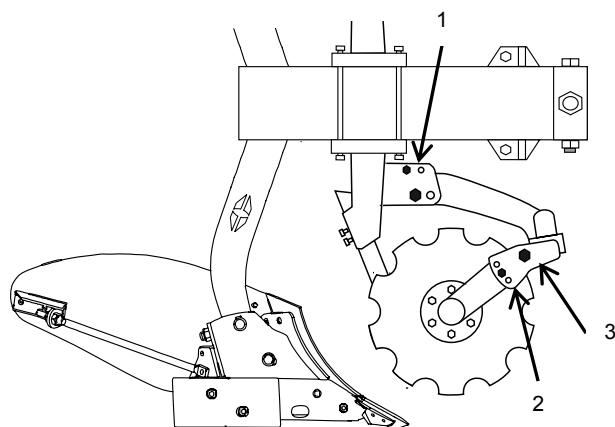

Disc coulters CCR 99 are fixed on skimmer mounting bracket through a welded plate.

They are available on both bolt safety device (B) and non-stop hydraulic safety device (Y or Z).

They have 500 mm diameter disc, notched or plain.

9.7.1. Front to rear adjustment

There are two ways to adjust distance between disc coulters and plough bottom. :

- positioning skimmer mounting bracket on element,
- positioning disc coulters support on the welded plate (bolts 1), two positions are available.

Ploughing in heavy trash conditions, coulters shall be ahead from element to prevent plugging.

9.7.2. Depth adjustment

Coulters depth is pre-adjusted at the manufacture for disc to cut slightly higher than the point (bolt 2 position). This adjustment shall be checked in the field. Once ploughing at desired depth, disc shall be :

- deep enough to cut all residues and / or roots (ploughing hay fields) = at least 7 or 8 cm ,
- high enough to prevent any contact of coulters hub on the ground and avoid wearing and / or plugging = 5 cm clearance between coulters hub and the ground.

Adjustment procedure

- Loose bolt 3
- Remove bolt 2
- Change coulters position
- Install bolt 2 in appropriate position
- Tight back bolt 3

10. MAINTENANCE

Follow recommendations given in the safety section of this manual. They are not restrictive.

10.1. GENERAL INSTRUCTIONS



Operator and user are responsible for good machine maintenance.



Inspect machine before and after each use. Repairs and service have to be done immediately so that they are not forgotten. Always leave the machine in a good state.

Cleaning the machine facilitates inspection. Check general state of machine, weldings, wheels studs, tyres, ...

Be careful with hydraulic lines : frictions may lead to excessive wearing and lines may leak. Never search a leak with your hands. Immediately replace any defective component. Spare components shall have the same characteristics.

Parts working in the ground may be sharpened and cause severe injury. Take particular care and use heavy leather gloves to remove them.

Never attempt any intervention on the machine while tractor engine is running.

Always properly secure all components before starting any maintenance operation underneath the machine.

Before using the machine for the first time, check all bolts tightness. Verify after 50 working hours and then at the beginning of each season. Pay special daily attention on :

- wheel studs tightness
- wearing parts bolts and nuts tightness in rocky or dry conditions (lots of vibrations).

Wrong waste management is a danger for environment : collect waste oil, paint removers, accumulators, worn tyres ... Bring them back to a distributor or to an authorized collector. Do not let them in the nature.

10.2. LUBRICATION

A good lubrication of all moving parts will both allow the machine to work fine and insure its long-lasting.

Grease fittings are installed on all pivot points. Grease both lubricates moving parts and chases away abrasive dust or water that could come into pivot points.

Use quality grease, type Unil – Opal MS02 or equivalent.

Always wipe grease fittings with a clean rag before introducing grease. Do not hesitate to change any worn or broken grease fitting. Check for good grease course.

Remove all grease accumulation around grease fittings or moving parts.

Refer to grease fittings placement on the following drawing. Grease every 50 working hours on a regular use. Hard or intense conditions would require more.

The best is to grease regularly with regular quantity. Do not over grease.

GREASE FITTINGS ON ELEMENTS

- Safety B 0 grease fitting
- Safety Y, Z or P 1 grease fitting on each element
- rod pivot pin
- Safety Y or Z : *for good greasing on pivot point, put machine in transport position and release pressure on hydraulic circuit*
- Variable width** 2 grease fittings on each side on each element (not shown)

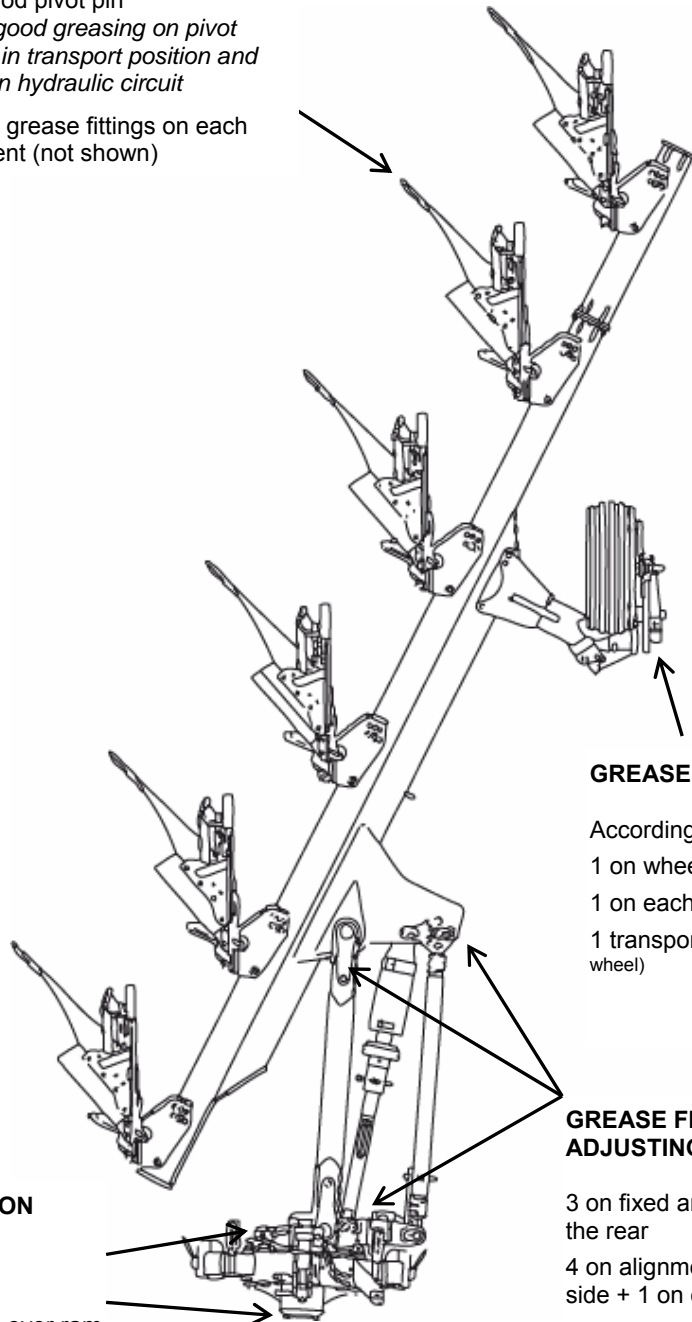

GREASE FITTINGS ON WHEEL

- According to model
- 1 on wheel hub
- 1 on each pivot point
- 1 transport position axle (combined wheel)

GREASE FITTINGS ON ADJUSTING ARMS

- 3 on fixed arm : 1 at the front + 2 at the rear
- 4 on alignment arm : 1 on each side + 1 on each threads
- 3 on front furrow alignment arm : 1 on each side + 1 threads
- 3 on variable width adjustment ram (not shown)

GREASE FITTINGS ON HEADSTOCK

- 2 on the shaft
- 1 on each end of turn over ram

10.3. SPARE PARTS

Genuine Grégoire-Besson parts have been specially designed and developed. Only the use of these parts will ensure proper fit, longevity and field quality work of the machine.



Using any other spare part than certified from Grégoire-Besson will void warranty.

Changing wearing parts too late may be cause of poor quality work (penetration troubles, poor mixing ...) and may damage structure parts°.

10.4. WORKING BOTTOMS MAINTENANCE

Protect all parts working into the ground (mouldboards, shares, shins, disc blades) from rust whenever the plough is not used by applying a light coating of oil or grease.

While working in sticky grounds, even for a short stop, cover mouldboard with a coat of light oil (WD 40 in spray).

For longer stops, heavier oil will stay longer on mouldboards. Dry spray type graphite also, this one being removed faster.

10.5. STORAGE SAFETY

- Before detaching the machine for storage, make sure ground is clean, flat and firm enough.
- Use parking stand and all other locking devices to prevent from any unforeseen movement during detachment or later on.
- Block machine wheels to avoid any unforeseen movement.
- During storage, wheels shall not carry any weight.
- NEVER detach machine in raised position.
- Remove pressure from hydraulic circuit (engine shut off, shake hydraulic control lever in the cab).
- Store machine away from human activity.
- Store machine in a dry and dust free area (shed). Protect ram rods that cannot be retracted from rust using grease or oil.

CAUTION : never let children play around farm equipment.

NOTES

11. QUICKLY STARTING - HRP W 7

Take all precautionary measures. Respect safety recommendations.

PREPARING THE TRACTOR

- 1. Check tyre pressure**
It should be the same on both sides on each axle.
- 2. Adjust tractor hitch levelling**
Set lift links length for tractor hitch to be perfectly level with the ground.
Arms shall be long enough so that working at desired depth there is still 30 mm chrome visible on lift ram.
- 3. Adjust lift links lateral sway**
Transport position minimal sway (≤ 1 cm)
Working position lateral sway 2 to 5 cm
- 4. Check top link**
Connexion between top link and machine must be done through a tie rod and not through an automatic hook.

HITCHING

- 5. Attach lower links**
- 6. Attach top link**
- 7. Make sure there are no interferences between machine and tractor from raised position to working position**
Machine shall never come in contact with tractor.
There should be no contact between tractor lift links and machine yoke hitch from raised position to working position.
- 8. Connect hydraulic lines**
- 9. Transport / working positions**
Transport position wheel in transport position, elements in horizontal position, safety lock pin installed, top link detached.
Working position wheel in working position, safety lock pin unlocked, top link properly attached.
- 10. Adjust stoppers on front furrow width ram**
Working position front adjuster opened wide enough for 1st furrow to cut the same width as the others, tractor being on land or in the furrow.
Turn over position plough realignment is done through front furrow width
plough shall be balanced for turn over manoeuvre : at the end of the manoeuvre movement must be sufficient and smooth = when machine reaches its working position, there shall be no need for hydraulic pressure and there shall have no shock
make sure wheel does not touch the ground during manoeuvre

FIRST PASS

- 11. Adjust + / - working width according to conditions**
- 12. Adjustment alignment**
Top link shall be lined up with tractor.
- 13. Adjust + / - working depth with wheel height**

SECOND PASS

14. **Adjustment alignment**

15. **Front to rear levelling**

Top link shall be positioned higher on machine side than on tractor side and shall be free in the slot while ploughing (adjust length).

Adjust both tractor hydraulic lift height and wheel height so that plough works in horizontal position at desired depth.

Check draft control adjustment and visible chrome visible on lift ram (30 mm minimum).

16. **Side to side levelling**

Elements shall be perpendicular with the ground.

17. **Adjust front furrow width of cut**

On land ploughing front adjuster widely opened + tractor properly positioned

In the furrow ploughing front adjuster opened so that front furrow cuts the same width as the other ones

MAINTENANCE

18. **Follow recommendations given in this manual according to lubrication and maintenance of the machine**

GRÉGOIRE  **BESSON**

**49230 MONTFAUCON-MONTIGNÉ-SUR-MOINE
FRANCE**

TÉL. (+33) (0)2 41 64 72 67

FAX (+33) (0)2 41 64 67 73

GRÉGOIRE-BESSON UK

Bourne Road, Carlby - STAMFORD LINCS PE9 4 NG – ENGLAND
phone (44) 01 778 590 223 - Fax (44) 01 778 590 645

GRÉGOIRE-BESSON CANADA INC

4480, Rue Martineau - ST-HYACINTHE (P. Québec) - CANADA J2R 1V1
TÉL. (1) 450 799 56 15 - FAX (1) 450 799 56 29

GRÉGOIRE-BESSON POLSKA

Ul. Obornicka 1a - PL - 64 600 OBORNIKI - Polska
TEL/FAX : (061) 29 77 530
gbesson@poczta.onet.pl
Ruda 12 - PL - 64610 ROGOZNO – TÉL / FAX (48) (67) 261 97 79

ООО «ГРЕГУАР-БЕССОН ВОСТОК»

Россия 308018 г. Белгород,
ул. Корочанская, 132а
Тел/факс: +7(4722) 58 70 36, 58 70 35
E-mail: info@gbvostok.ru

法国格力格尔 - 贝松公司北京代表处
北京市朝阳区延静里中街3号长信大厦220室
邮编：100025

WEB : www.gregoire-besson.fr **E.MAIL** : Contactfr@gregoirebesson.fr