

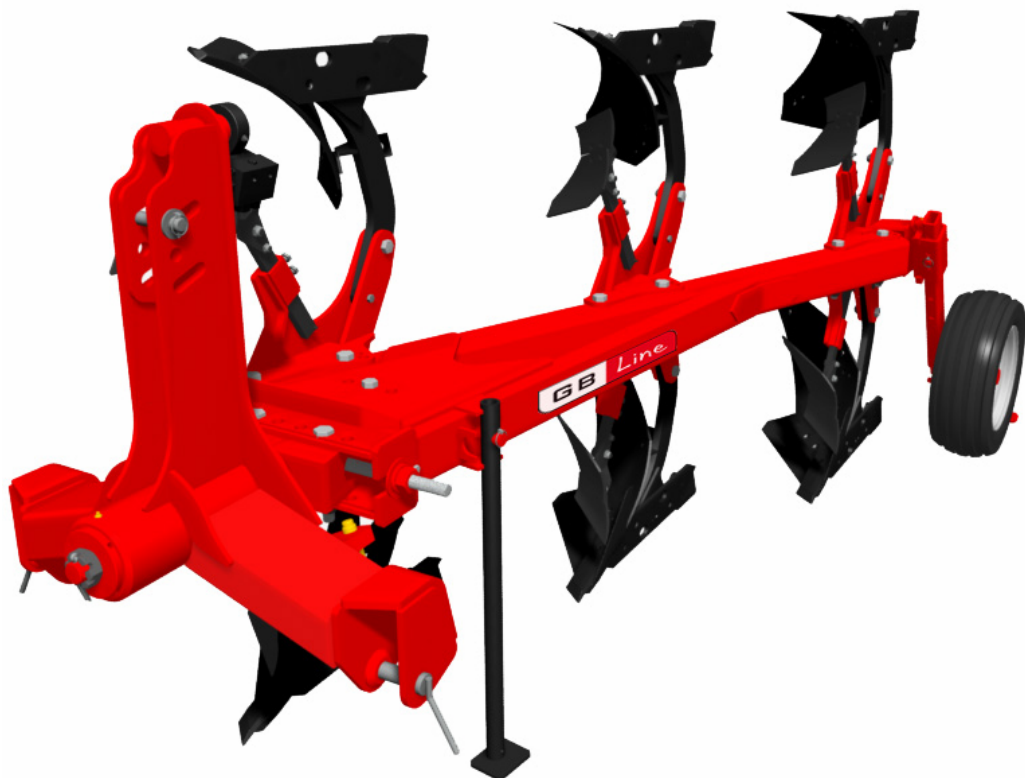

GB Line - PRIMA

Fully mounted reversible plough
Hydraulic variable width

OPERATOR'S MANUAL MAINTENANCE INSTRUCTIONS



GRÉGOIRE-BESSON S.A.
Rue Victor Grégoire
49 230 MONTFAUCON – MONTIGNÉ
France

Tél. : 33 (0) 2 41 64 72 67
Fax : 33 (0) 2 41 64 67 73

Web : www.gregoire-besson.com
Email : Contactfr@gregoirebesson.com

June 2008

TABLE OF CONTENTS

1. INTRODUCTION	3
PRODUCT IDENTIFICATION	3
2. SAFETY INSTRUCTIONS	4
2.1. SAFETY STICKERS	4
2.2. SAFETY WHILE ATTACHING AND DETACHING	6
2.3. SAFETY WHILE CONNECTING HYDRAULIC LINES	6
2.4. SAFETY WHILE OPERATING MACHINE	6
2.5. SAFETY FOR MAINTENANCE	7
2.6. SAFETY FOR ON HIGHWAY TRANSPORT	7
3. MACHINE DESCRIPTION	8
3.1. IDENTIFICATION VIEWS	8
3.2. TECHNICAL SPECIFICATIONS	9
3.3. DIMENSIONS AND WEIGHTS	9
4. PREPARING THE TRACTOR	10
4.1. TRACTOR WHEELS	10
<u>4.1.1. Tractor tyres</u>	10
<u>4.1.2. Distance between tractor tyres</u>	10
4.2. FRONT END WEIGHTING	10
4.3. POSITIONING STABILIZERS OR SWAY BLOCKS	11
4.4. LIFT LINKS LENGTH	11
5. ATTACHING AND DETACHING	12
5.1. ATTACHING MACHINE TO TRACTOR	12
<u>5.1.1. Tractor equipped with tie rods lower links</u>	12
<u>5.1.2. Tractor equipped with automatic hooks lower links</u>	12
<u>5.1.3. Hitching top link</u>	13
5.2. DETACHING THE MACHINE	13
6. HYDRAULIC CONNEXIONS	14
6.1. REQUIRED HYDRAULIC REMOTES	14
6.2. REQUIRED HYDRAULIC PRESSURE	14
6.3. HYDRAULIC CONNECTIONS	14

7. PREPARING THE MACHINE	15
7.1. ADJUSTING POINTS LOCALIZATION	15
7.2. MACHINE WHEEL	16
<u>7.2.1. Tyre inflation</u>	16
<u>7.2.2. Wheel studs</u>	16
<u>7.2.3. Height adjustment</u>	16
<u>7.2.4. Wheel turn over speed</u>	16
7.3. CHOOSING WORKING WIDTH	17
<u>7.3.1. Front furrow adjustment</u>	17
<u>7.3.2. Bottom individual width of cut adjustment</u>	17
7.4. ALIGNMENT ADJUSTMENT	18
7.5. PREPARING PLOUGH BOTTOMS	18
8. FIELD ADJSUTMENT	19
8.1. FIELD UTILIZATION	19
8.2. FIRST PASS	20
<u>8.2.1. Entering into the ground</u>	20
<u>8.2.2. Alignment adjustment</u>	20
<u>8.2.3. Ploughing depth adjustment</u>	20
8.2.3.1. Tractor hydraulic hitch height adjustment	20
8.2.3.2. Tractor draft control adjustment	20
8.2.3.3. Gauge wheel height adjustment	20
8.3. SECOND PASS	21
<u>8.3.1. Alignment adjustment</u>	21
<u>8.3.2. Front to rear levelling</u>	21
<u>8.3.3. Side to side levelling</u>	22
8.4. CHANGING SAFETY BOLT	22
8.5. SKIMMER ADJUSTMENT	23
<u>8.5.1. Shear bolt safety device</u>	23
<u>8.5.2. Skimmer height adjustment</u>	23
9. MAINTENANCE	24
9.1. GENERAL INSTRUCTIONS	24
9.2. LUBRICATION	24
9.3. SPARE PARTS	26
9.4. WORKING BOTTOMS MAINTENANCE	26
9.5. STORAGE SAFETY	26
10. QUICKLY STARTING - GB Line Prima	27

Any use and / or reproduction of all or part of this manual without written authorization from Grégoire-Besson is strictly prohibited.

1. INTRODUCTION



READ CAREFULLY THIS MANUAL



To properly start, operate and service your equipment, follow all instructions given in this manual.

THIS MANUAL SHOULD BE CONSIDERED AS A PART OF THE EQUIPMENT AND SHOULD FOLLOW IT WHEN YOU SELL IT.

LEFT HAND SIDE AND RIGHT HAND SIDE, FRONT AND REAR are determined looking from equipment towards tractor when in work.

ALL INFORMATIONS, PICTURE, SPECIFICATIONS in this manual are based on the newer information available at the time of publication. Pictures and drawings might not represent standard equipment and show optional attachments.

Manufacturer reserves right to make any changes at all time **without any obligation to notice or to modify any delivered or already sold machine.**

If the machine has been modified in any way from the original design without written agreement from Grégoire-Besson, the manufacturer does not accept any liability for injury or warranty. Warranty would become void.



This symbol is used in the following manual to **catch your attention on warnings concerning your safety.**

So please when you see it in this manual or on the equipment, **strictly follow given information.**

Grégoire-Besson equipments are exclusively designed to be used by professionals for regular farm tillage in farmed fields. Manufacturer shall not be responsible for damage or injury resulting from any other use.

PRODUCT IDENTIFICATION

Please record here purchasing date, model and serial number of your equipment (refer to identification plate on hitch). Always refer to these information to get prompt and good service.

Purchasing date :

Model :

Serial number :

Salesman's phone :

2. SAFETY INSTRUCTIONS

2.1. SAFETY STICKERS



READ OPERATOR'S MANUAL

Read operator 's manual and safety instructions before starting the use of your equipment and follow them while using.

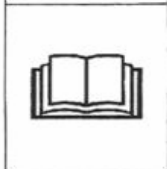

Reference : UI 128



UNFOLDING AREA

Stay clear of equipment when folding or unfolding.

Reference : UI 126



MOVE AWAY FROM THE MACHINE

Danger in the working area, stay clear from the machine.

Reference : UI 127



SECURE THE MACHINE BEFORE ACTION

Always install all lockup devices to secure machine before any intervention on it.

Reference : UI 131



HYDRAULIC LEAK AND MAINTENANCE

Caution, high pressure fluids can cause injury. Follow safe practices.

Reference : UI 128



Positioning safety stickers on the machine

When cleaning the machine, do not damage stickers.
Replace any damaged or missing sticker.

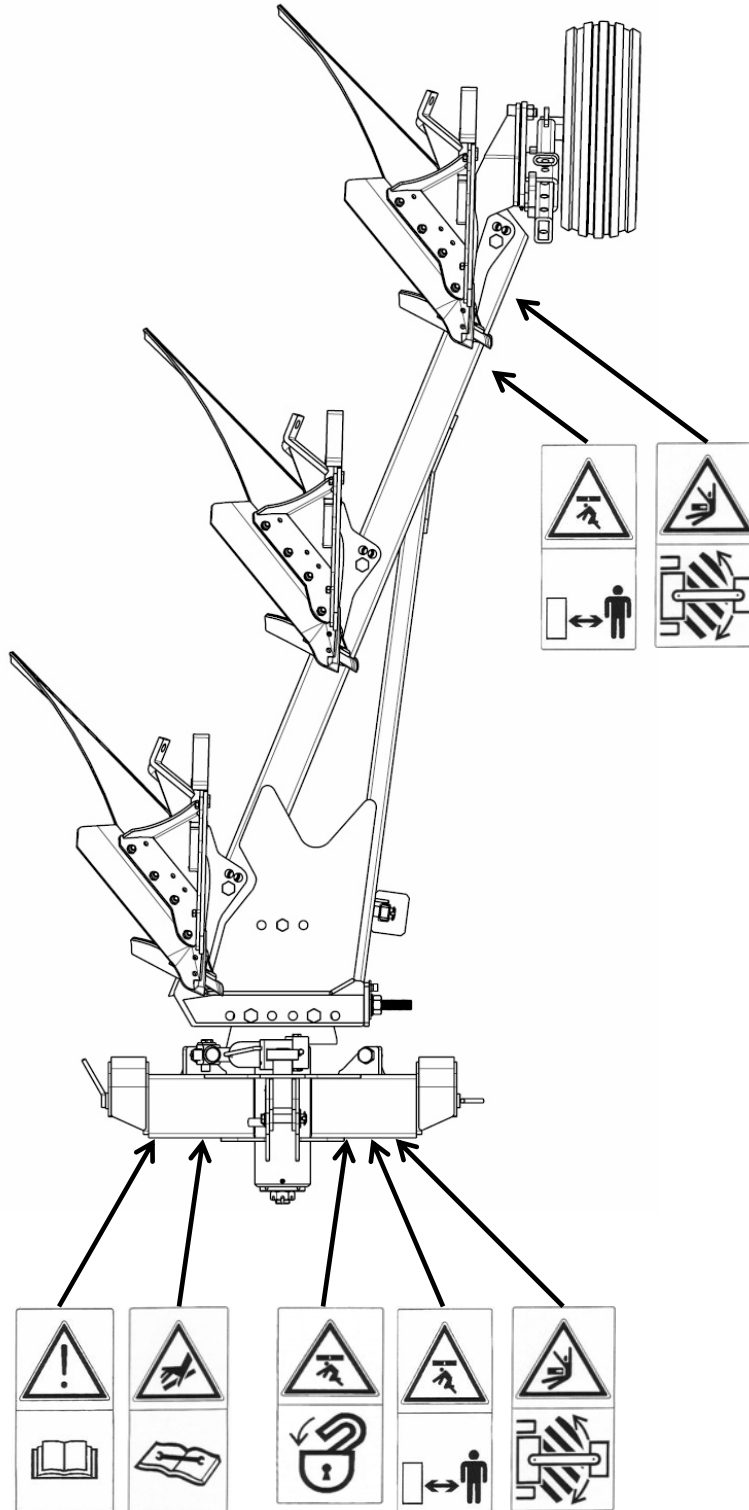

2.2. SAFETY WHILE ATTACHING AND DETACHING



- Do not let **anyone to stand between the machine and the tractor** when you back up to hitch.
- Before leaving the tractor to hitch or unhitch, set tractor parking brakes.
- Never attempt to attach the machine if pins, tractor hitching balls, tractor drawbar, or machine linkage are worn, cracked or not compatible.
- Completely lower the machine to the ground before unhitching. Make sure it is on a level and firm surface.
- Remove pressure from hydraulic lines before disconnecting them.
- Before leaving the machine for storage, make sure it is in a safe place and that there is no risk to damage whether anything or anyone.

2.3. SAFETY WHILE CONNECTING HYDRAULIC LINES



- Hydraulic circuit might be highly pressurised.
- **Never use your hands to locate a hydraulic leak.** Hydraulic fluids escaping under pressure have sufficient force to penetrate the skin, causing severe injury. In case of any injury, **see a doctor immediately.**
- For equipments loaded with several hydraulic connectors, **make logical and appropriated connections.**
- Before connecting hydraulic circuit, **make sure that there is no pressure on both sides (tractor and machine).**
- Regularly check hydraulic lines and connections. **Replace any damaged or leaking component** by an original part with the same specifications.
- Before any intervention on hydraulic circuit, **lower machine to the ground and release pressure moving control lever in the tractor's cab.**

2.4. SAFETY WHILE OPERATING MACHINE

- **Never attempt** any intervention on the machine while it is in motion.
- Do **not** allow anyone to **stand close to pivot points** : bottoms safety device (shearing bolt or non-stop), all pivoting linkage.
- Wear close **fitting clothing** and **appropriate safety devices** for the job you have to do (heavy leather gloves, safety shoes, earplugs, ...).
- Do not allow anyone to stand close to the machine.
- Do not attempt to do any adjustment if you have not perfectly understood its procedure.
- Always use tools or equipments appropriate to the job you are doing. All Grégoire-Besson equipments are metric standards.
- Learn how to operate your machine and how to use its controls. Do not let anyone operate without instruction.
- Do not extend turnbuckle adjusters too much to avoid any threads damaging or intempesive pulling out.
- Only one person (the operator) should be in the tractor's cab when it is in operation. **No one on the machine while working or travelling on the road.**
- When earring or feeling unusual vibrations, stop the machine. Find the problem and solve it before starting operating again.



If your machine is equipped with a hydraulic folding mechanism, **always use it from tractor's cab**, once you are sure that folding area is free from spectators or obstacles.

2.5. SAFETY FOR MAINTENANCE



- Maintenance area shall be **clean, dry, with enough light and ventilation**.
- For any intervention on the machine in raised position, **always securely support all components** before starting maintenance.
- **Maintenance operations on elements under pressure or under tension** (resorts, accumulators, ...) require specific procedure and equipments. **Only qualified persons shall perform them in appropriate conditions**.
- After servicing remove all tools, components and parts you used.
- Regularly **check tightness of wheel studs, wearing parts bolts, and all other bolts and nuts**.
- **Always use genuine parts corresponding to manufacturer's technical specification requirements**.

2.6. SAFETY FOR ON HIGHWAY TRANSPORT



FOR YOUR OWN SAFETY AND THE ONE OF THE OTHER, RESPECT THE FOLLOWING RULES :

- All Grégoire-Besson equipments shall be used **complying with area's current rules and laws** concerning **safety instructions, accident prevention and provision of Highway Code**.
- Before road transport, always **check for wheels studs** and wheels mounting brackets carriage bolts **tightness** ; **check tyres general state and pressure** : do not drive with low pressure, cuts or damaged tyres or rims.
- **Use all devices required by your area's current laws** (lights, reflectors, signs, ...). They might be removed during field operation to prevent from any damage. It is the operator's responsibility to comply with current law and to follow its evolutions.
- Regularly check hitching pins, change them if necessary. Tractor's ball joint may also wear, do not hesitate to replace them with new ones having at least Waltersheid fabrication quality.
- Drive **at reasonable speed** complying with local laws **to always keep control** of tractor and equipment. Pay special attention on irregular or rough roads. **Do not attempt to drive down a hill faster than it could be possible to drive it up**.
- Tractor used for road transport shall have the same power rating and weight as the one used for field operations.
- **Never attempt any manoeuvre if area is not free from spectators**.
- If your machine is equipped with a **folding mechanism** (manual or hydraulic), **use it making sure folding area is free from spectators** and obstacles.
- Follow all **safe driving practices** when travelling, moreover **on corners, rough or narrow roads**.
- When **leaving tractor** even for a short period, **shut off engine, remove ignition key and set parking brakes**.
- Forbid anyone to stand between tractor and machine or on the machine travelling on the road.

3. MACHINE DESCRIPTION

3.1. IDENTIFICATION VIEWS

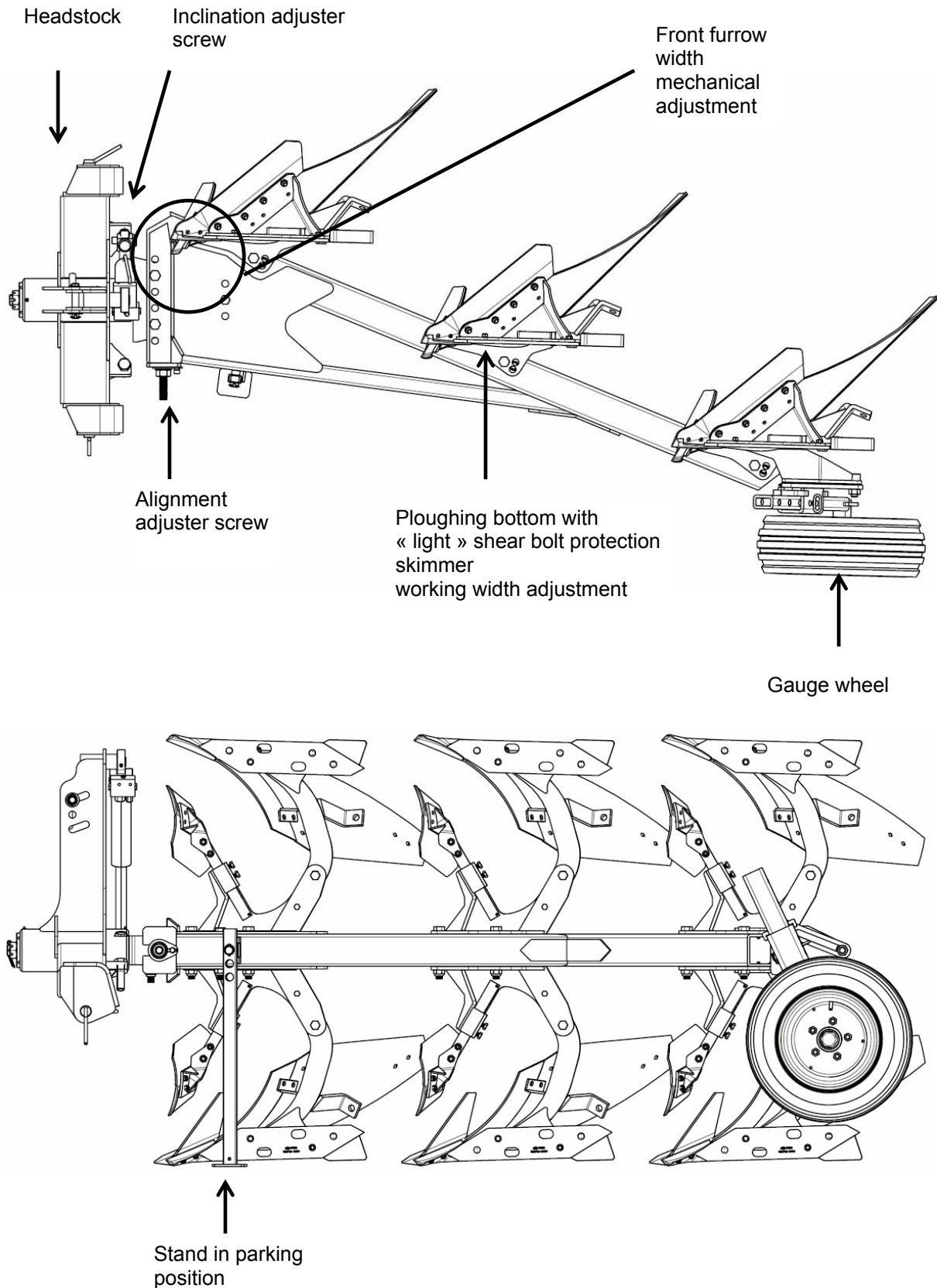

3.2. TECHNICAL SPECIFICATIONS

Specification	Standard equipments
Head stock	<ul style="list-style-type: none"> • Fixed hitch cat. II • Hydraulic ram for turn over • Shaft Ø 80 mm • Mechanical stoppers for inclination adjustment
Frame	<ul style="list-style-type: none"> • Main frame 120x120x9 mm 3 or 4 bottoms • No extension possibilities
Working width	<ul style="list-style-type: none"> • 12", 14" or 16" = 30 cm, 35 cm or 40 cm
Alignment adjustment	<ul style="list-style-type: none"> • Mechanical with screw
Front furrow adjustment	<ul style="list-style-type: none"> • By bolt, positioning main frame on shaft support
Inter body clearance	<ul style="list-style-type: none"> • 100 cm
Point to point clearance	<ul style="list-style-type: none"> • 160 cm = 74 cm under frame
Safety device	<ul style="list-style-type: none"> • Shearing bolt « light », C type
Gauge wheel	<ul style="list-style-type: none"> • Height adjustable (mounting bracket) • Tire 600 x 8
Bottoms	<ul style="list-style-type: none"> • Plain share or self sharpening share with reversible point • Mouldboard helicoidal (H5) or cylindrical (C16) • <i>As an option : slatted mouldboard (CV7)</i>
Skimmers	<ul style="list-style-type: none"> • Height adjustable • Shear bolt safety protection • Mixed, manure or deflectors • <i>As an option : universal, euro, maize or pasture skimmers</i>

A large choice of options is available to improve machine's job. Do not hesitate to contact and authorized Grégoire-Besson dealer.

3.3. DIMENSIONS AND WEIGHTS

Nb of bottoms	Working width		Over all length	Required horse power	Indicative weight
3	12" to 16 "	0.80 m to 1.20 m	3.40 m	75 hp	820 kg
4	30 to 40 cm	1.20 m to 1.60 m	4.40 m	90 hp	1 070 kg

Dimensions and weights are indicative and subject to variations according to equipments and options.

Note : after use, ground or residue accumulations may increase machine's weight.

4. PREPARING THE TRACTOR

Follow recommendations given in the safety section of this manual. They are not restrictive.

4.1. TRACTOR WHEELS

4.1.1. Tractor tyres

Check tractor tyres general state and pressure. Pressure should be the same on both sides of the tractor for a nice drivability in the field and on the road.



IMPORTANT : inflate tyres following manufacturer's recommendations.

4.1.2. Distance between tractor tyres

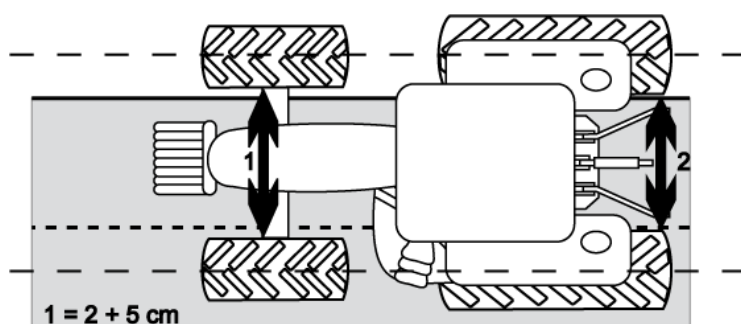

Generally, using a plough with large number of bottoms, the wider is the distance between tyres, the better is the drivability.

To be able to steer the tractor in the furrow, the middle of the front axle shall be lined up with the middle of the rear axle. This would also prevent from useless friction of front wheel on the furrow wall.

Minimum inter tyre distance (2) : 0.94 m.

Maximum inter tyre distance (2) : 1.38 m.

4.2. FRONT END WEIGHTING

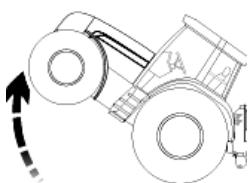

Wheels weights (front and rear) and front end weights may be required to avoid excessive slippage and to increase stability in rough and sloppy grounds.

Weights shall not be added once all slippage is eliminated. Refer to tractor operator's manual and to tractor's dealer. Follow tyre manufacturer's recommendations.

4.3. POSITIONING STABILIZERS OR SWAY BLOCKS



STABILIZER

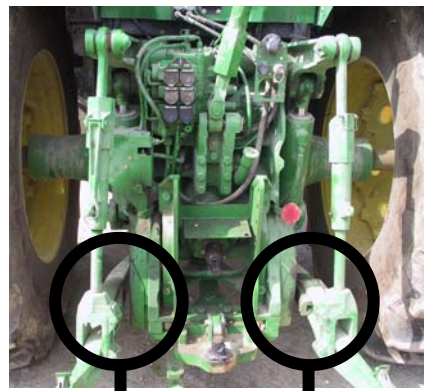

BLOCKS

To hitch equipment on lower link arms, stabilizers shall be positioned to have a minimum sway (≤ 2 cm) and lined up with tractor draw line. This will prevent any risk of shock during manoeuvre and transport. Machine will stay lined up behind tractor.

Note : it is easier to adjust and / or service stabilisers bolts and threads before hitching the machine.

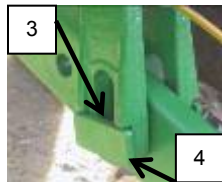

Horizontal lift links pins (3) shall be in fixed position (4) to avoid any loose and / or damageable shock.

4.4. LIFT LINKS LENGTH

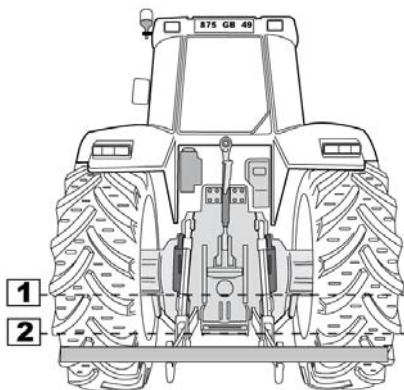

Lift link arms length determines tractor hitch levelling and lift cylinder position at working depth.

- Set lift links length so that tractor hitch is level (refer to picture).
- Set lift links length to have at least 30 mm clearance on lift cylinder rod when machine is working at desired depth. This will give possibilities for hitch adjustment from the cab and allow efficient tractor draft control

5. ATTACHING AND DETACHING

Follow recommendations given in the safety section of this manual. They are not restrictive.

IMPORTANT : always make sure that hitching never leads to :

- overload : respect maximum hitch capacity
- unbalance: load tractor front end if necessary. Refer to point 4.2.

5.1. ATTACHING MACHINE TO TRACTOR

Before any manoeuvre, check for diameter and length compatibility between hitch pins and tractor tie rods.

5.1.1. Tractor equipped with tie rods lower links

- Remove safety bolts and hitch pins.
- Back up tractor to line up tie rods and machine hitch holes.
- Install pins and secure them with their safety clips.
- If holes are difficult to line up : extend telescopic arms as indicated in tractor operator's manual. Once hitch pins are inserted and secured with their safety clips, slowly back up tractor to lock back lift arms. Check for lift arms locking.
- Hitch top link.

5.1.2. Tractor equipped with automatic hooks lower links

- Remove safety bolts and hitch pins.
- Remove balls from tractor lift link automatic hooks.
- Check for balls and pins general state and compatibility.
- Install balls on pins through lower machine hitching holes. Secure with safety bolts.
- Slowly back up tractor till automatic hooks are lined up underneath hitch balls.
- Raise tractor hitch about 5 cm above ground surface till automatic hooks are locked.
- Check for automatic hooks latch handles good locking.
- Hitch top link.



IMPORTANT : before hitching top link, **make sure to have enough clearance between machine yoke hitch and tractor lower lift links to avoid any possibility of contact from working to raised position. A second verification shall be done once machine is in the field in truth working conditions.**

5.1.3. Hitching top link

Once tractor lift links are correctly hooked up, check top link general state and compatibility with tie rod. Then **attach top link : through a slot in working position, through a fixed hole in transport position.**

Raise machine to the maximum and make sure there are no interference with tractor. Final top link adjustments (length and position) will be made in the field.

Put parking stand in working position : remove safety clip and pivot it into horizontal position. Do not forget to install safety clip back.



IMPORTANT : make sure to have enough clearance between machine yoke hitch and top link to avoid any contact from working to raised position. A second verification shall be done once machine is in the field in truth working conditions.

Connect hydraulic turn over circuit.

5.2. DETACHING THE MACHINE

Before detaching, make sure that ground is flat and firm enough to support the machine. Use safety blocks to support machine components if necessary.



DANGER : do not let any part of your body underneath the machine when lowering it to the ground.
Crushing may lead to death.

Proceed in the logical attaching opposite way :

- 1) Put machine in working position = it shall stay on its bottoms L.H. or R.H. side
- 2) Put stand in parking position = vertical
- 3) Completely lower the machine to the ground,
- 4) Detach top link
- 5) Disconnect hydraulic turn over circuit
- 6) Detach lower lift links

Always operate with care.

6. HYDRAULIC CONNEXIONS

Follow recommendations given in the safety section of this manual. They are not restrictive.

6.1. REQUIRED HYDRAULIC REMOTES

- 1 DA for turn over

6.2. REQUIRED HYDRAULIC PRESSURE

Required tractor hydraulic pressure is 180 to 200 bars.

6.3. HYDRAULIC CONNECTIONS

- Always wipe hydraulic couplers with a clean rag on both tractor and machine sides before connecting circuits.
 - Always check for machine hydraulic connectors and tractor remotes compatibility.
 - Logically connect hydraulic lines for the user :
- ⇒ Put most frequently used functions on closest lever
- ⇒ Watch for the way hydraulic flow is delivered : pull the lever to put machine in transport position (raise up / fold), push it to put machine in working position (lower / unfold).
- ⇒ Identify hoses using colour collars and signs (+ to extend rods, - to retract them).
- Check for hydraulic hoses length : too short they may break during sharp turns, too long they may interfere with tractor lift arms or tyres.

In case of any problem, do not hesitate to contact an authorized Grégoire-Besson dealer.

7. PREPARING THE MACHINE

Follow recommendations given in the safety section of this manual. They are not restrictive.

7.1. ADJUSTING POINTS LOCALIZATION

Find adjusting points and check their lubrication and work. Doing this checking task close from a machine shop is better than doing it in the field.

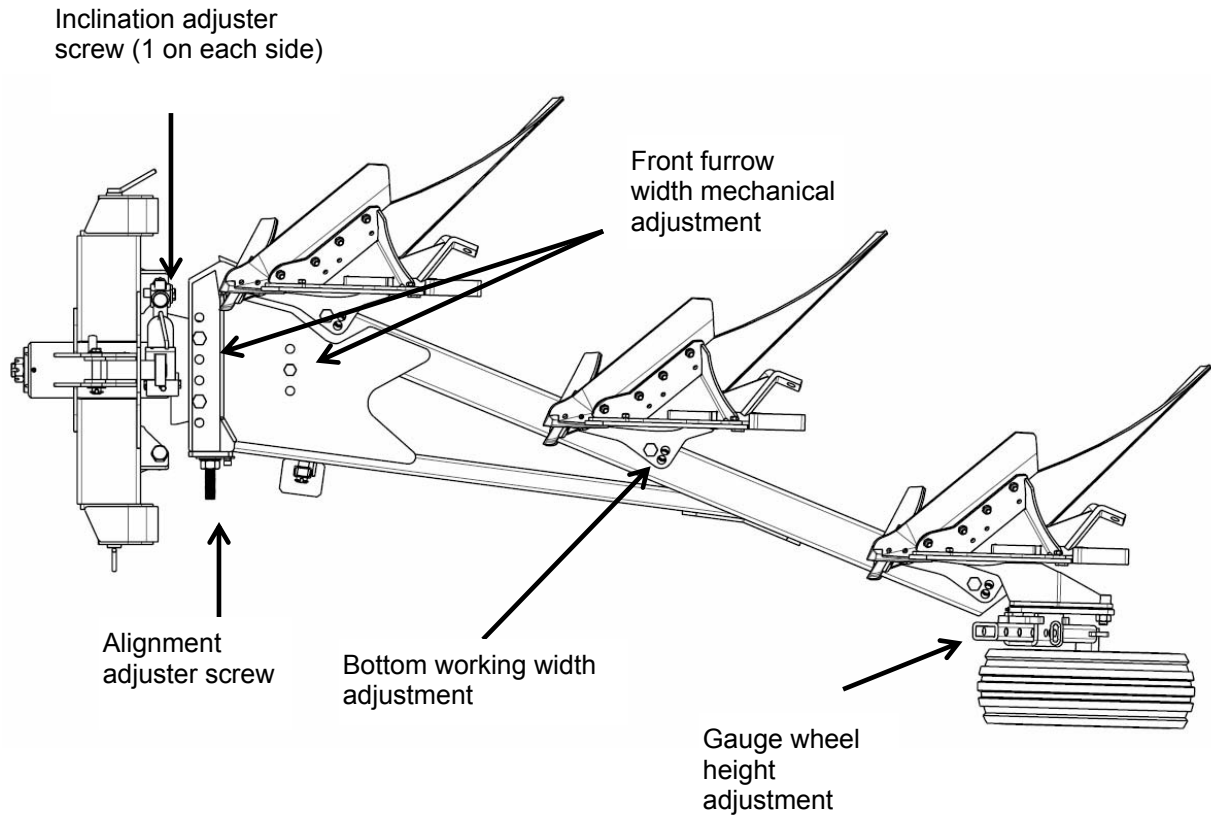

7.2. MACHINE WHEEL

7.2.1. Tyre inflation

Air pressure shall be checked every week. Do not let it drop below recommended pressure.

Tyre dimension	Recommended pressure
600 x 8	4.0 bars

Follow tyre manufacturer recommendations (written on tyre side).



Tyre « above - inflation » = exploding risk.
Tyre « below - inflation » = rim come off risk.

7.2.2. Wheel studs

Check wheels general state and studs tightness every day.

7.2.3. Height adjustment

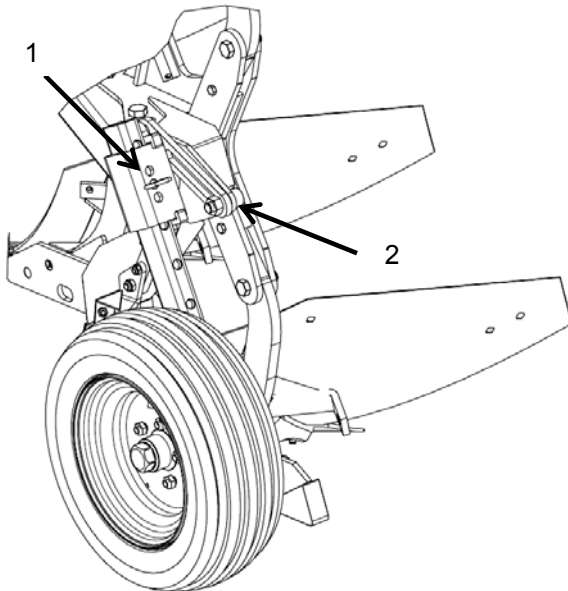

Wheel height adjustment controls rear furrows ploughing depth.

- To increase working depth, wheel shall be raised.
- To decrease working depth, wheel shall be lowered.

Adjustment procedure :

- Remove safety clip (not shown) and pin 1.
- Raise or lower wheel till desired position.
- Install pin 1 back. Do not forget safety clip.

7.2.4. Wheel turn over speed

Bolt 2 tightness may limit wheel block speed during turn over operation.

- Tight bolt 2 to reduce speed.
- Loose bolt 2 to let block free during this operation.

Note : excessive tightness may lead to wheel turn over impossibility.

7.3. CHOOSING WORKING WIDTH

The chart hereafter given indicates correspondences between individual bottom working width, front furrow position and tractor's inter tyre distance (= distance Y inside to inside or rear tyres).

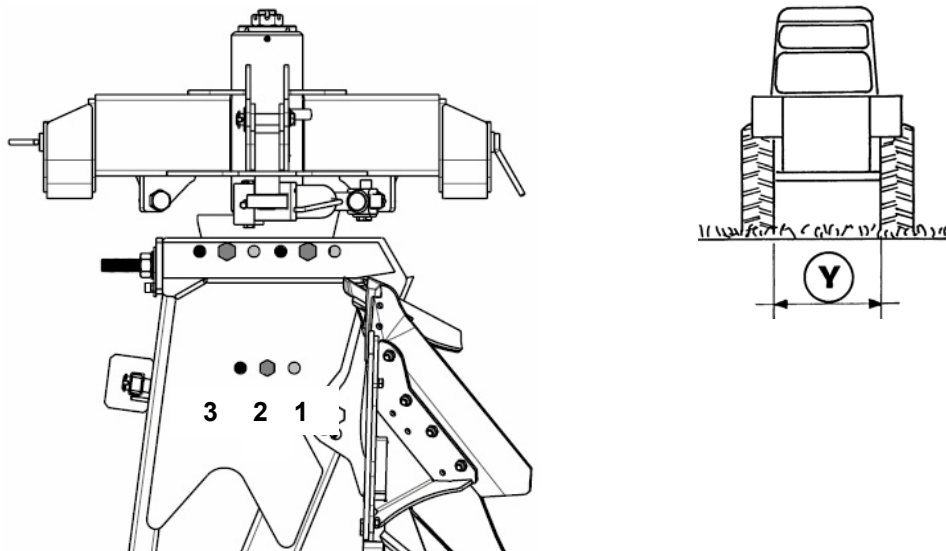

Working width	Settlement 1 (pale)	Settlement 2 See picture (grey)	Settlement 3 (black)
12"	934 mm	1 054 mm	1 174 mm
14"	1 044 mm	1 164 mm	1 284 mm
16"	1 153 mm	1 273 mm	1 383 mm

7.3.1. Front furrow adjustment

Front furrow width of cut has to be adjusted to be the same as following. This adjustment is done by bolting main frame on shaft support. There are three available positions.

Adjustment procedure :

- Remove the three carriage bolts (bolts in position 2 = grey position on picture).
- Move main frame to reach the desired position.
- Install carriage bolts back.

7.3.2. Bottom individual width of cut adjustment

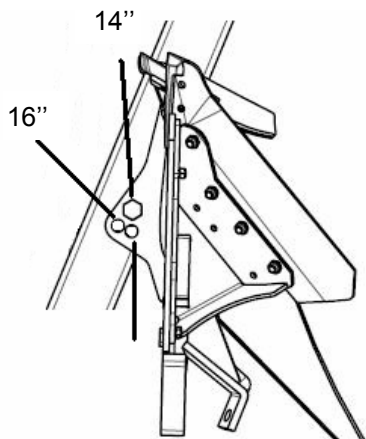

There are three available positions to set individual bottom's working width : 12", 14" or 16" (= 30 cm, 35 cm or 40 cm).

Adjustment procedure :

- Raise the machine so that it does not touch the ground.
- Remove carriage bolt (position 14" on the picture).
- Pivot element support to reach desired position (slightly loosening front bolt, not shown, might help).
- Install carriage bolts back.

7.4. ALIGNMENT ADJUSTMENT

Alignment adjustment allows plough positioning behind tractor so that traction line of both bottoms and tractor are lined up. Then useless side draft is minimum and plough steering is easy.

When alignment is properly set, top link shall be strictly lined up behind tractor and lift links arms are free (2 to 5 cm loose). Final adjustments shall be done in the field.

7.5. PREPARING PLOUGH BOTTOMS

Grégoire-Besson plough bottoms are protected before leaving the factory to prevent rusting. Good field work can not be accomplished until this coating is removed : mouldboards do not shine, ground is stuck to the steel.

If necessary, use a solvent, such as paint remover to take the protective black paint off.



CAUTION: keep work area well ventilated when using solvent such as paint remover to remove protective paint. Wear eye and hand protection.

8. FIELD ADJSUTMENT

Follow recommendations given in the safety section of this manual. They are not restrictive.

8.1. FIELD UTILIZATION

To reach a decent ploughing, operating speed shall be between 5 and 7 km / h (= 3 to 4.5 mph). Higher speed may lead to over wearing of wearing parts.

Always lift up machine before manoeuvring or turning on headlands.

Never attempt a sharp turn with the machine in the ground.

Reduce speed before manoeuvring or crossing obstacles (ditch, ridge, rocky spots, ...).

As long as possible, regularly change field opening side to avoid rolling ground always the same way. This could result in creating a ridge on one side of the field and a ditch on the other side.

Several up and down passes might be necessary before reaching an optimum ploughing, moreover with a new plough or at the beginning of a new season. During each pass, mouldboards get more polished, soil flow gets better and adjustments can be improved.

IMPORTANT : before beginning field utilization, entirely read this chapter to understand all adjustments, their order and procedure.

IMPORTANT : always do one adjustment at a time. Then it is easier to check its performance and to change it if necessary.

8.2. FIRST PASS

First pass differs from the others since tractor is not running in the furrow. This interferes with several adjustments : inclination and front furrow (width and depth).

8.2.1. Entering into the ground

Drive slowly and lower the machine to have a smooth entering into the ground.

8.2.2. Alignment adjustment

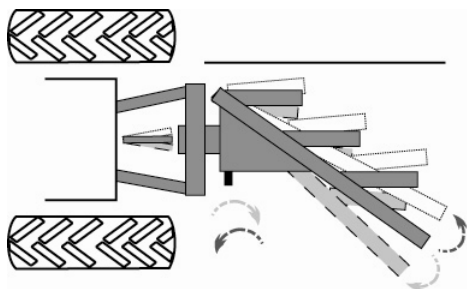

When plough is working in the ground, it shall be lined up with tractor. Refer to section 7.4.

- Lower lift link arms shall be free (no pressure on stabilization devices).
- **Top link** shall be **strictly lined up** behind tractor.
- If **top link** looks **towards ploughed ground**, plough shall be lined up with tractor traction line **turning adjusting screw clockwise**.
- If **top link** looks **towards non ploughed ground**, plough shall be lined up with tractor traction line **turning adjusting screw counter clockwise**.

8.2.3. Ploughing depth adjustment

Ploughing depth is controlled by :

- tractor hydraulic hitch height for the front end of the plough,
- gauge wheel height for the rear end of the plough.

8.2.3.1. Tractor hydraulic hitch height adjustment

Tractor hitch height is controlled from the cab. For the first pass first bottom cannot fill any furrow with ground. So set hitch height so that there is no formation of an excessive ridge.

8.2.3.2. Tractor draft control adjustment

To begin, set draft control on a minimum sensibility. Therefore front furrow depth will be easier to check and / or to adjust.

Later on, once plough is properly adjusted, draft control sensibility may be increased to improve tractor's adhesion.

Note : in bad conditions (wet fields, low horse power reserve, ...) it is impossible to work with minimum draft control. Hitch reactions to the load shall then be taken in account for average front furrow working depth estimation.

8.2.3.3. Gauge wheel height adjustment

Gauge wheel height may be approximately adjusted during first pass. Checking and / or readjustments will be done on the following passes (refer to section 7.2.3.).

8.3 SECOND PASS

Before any final adjustment, make sure mouldboards are scoured. Ground shall slide along steel and never stick. In heavy conditions, removing bolted points for the first working hours might help scouring mouldboards. Do not hesitate to contact an authorized Grégoire-Besson dealer in case of problem.

8.3.1. Alignment adjustment

Check for good alignment adjustment. Plough shall be properly lined up behind tractor, top link strict. Landsides shall slide along furrow wall, without excessive pressure.

8.3.2. Front to rear levelling

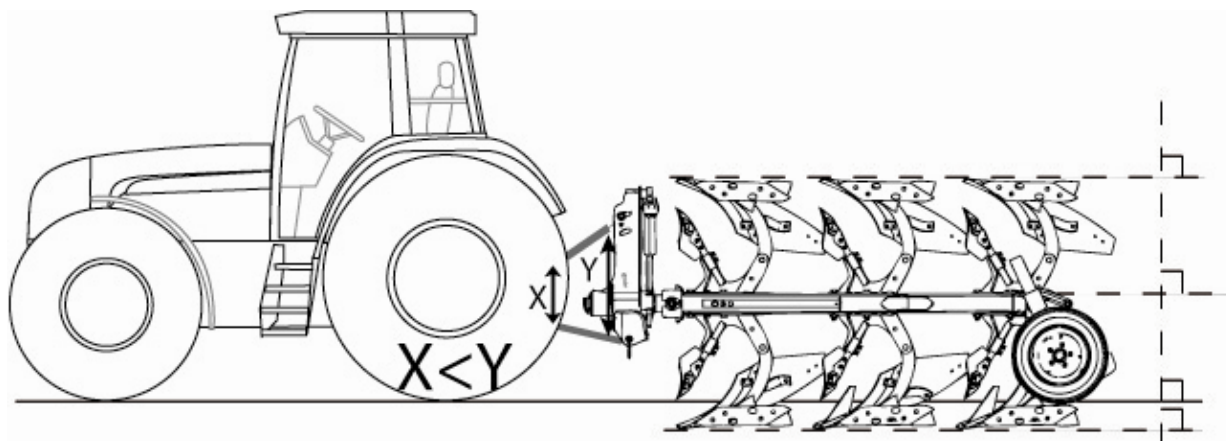

Once tractor runs in the furrow, plough has to be levelled from front to rear so that all bottoms work at the same depth (refer to picture).

Adjustment procedure

- For the desired ploughing depth, find the right balance between tractor hydraulic hitch height, gauge wheel height and top link length.
- **Top link position** : at work, top link shall always be positioned higher on machine side than on tractor side. This will allow a good weight transfer on front axle. Refer to picture, $X < Y$. Attach top link in the right slot and / or move its position on tractor side if necessary.
- **Top link length** : top link length shall be adjusted so that working at desired depth top link pin stays free to move in the slot. This will allow good weight transfer and easy plough front to rear levelling.
- Any wheel height modification leads to verifications : tractor hydraulic hitch position, top link position and length.

8.3.3. Side to side levelling

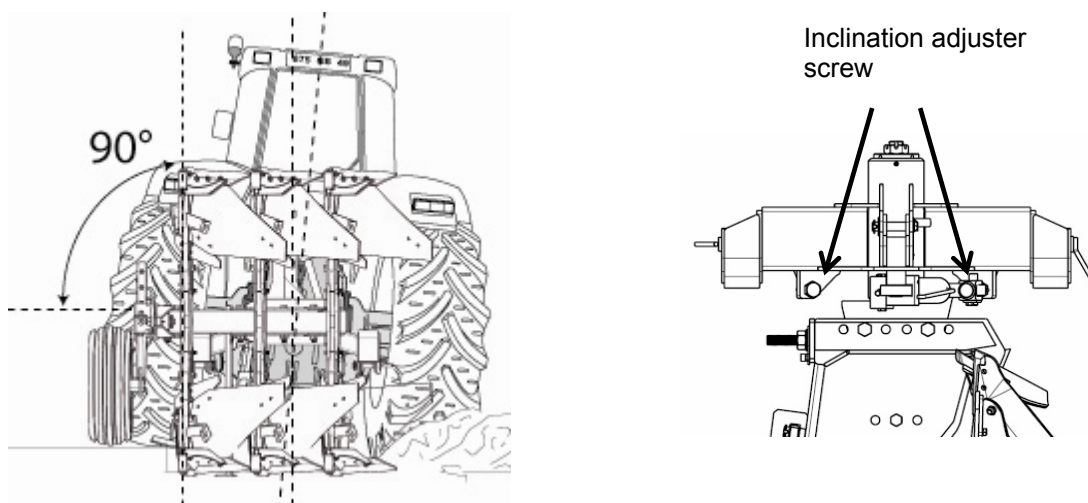

Once tractor runs in the furrow, plough shall be levelled from side to side. Bottoms shall run perpendicular with the ground. Refer to picture.

In specific conditions (sloping fields, heavy clay, ...) plough may be slightly tilted towards ploughed ground to increase mouldboard action on the soil.

Adjustment procedure :

- Raise plough so that it does not touch the ground.
- Act on turn over hydraulic control lever to remove pressure from inclination adjusters.
- Loose jam nut and turn adjuster as required.
- Put machine back in working position and start working again.
- Change adjustment till you reach the right position, with element perpendicular with the ground.
- Inclination shall be adjusted apart from side to side.

8.4. CHANGING SAFETY BOLT

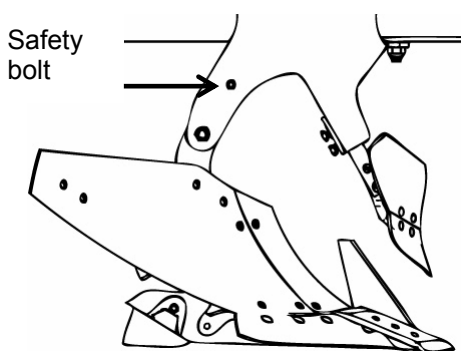

When hitting an obstacle (rock, stump, ...) safety bolt shall break so that element can raise to prevent any damage. In case of any bolt breaking, it shall be replaced by genuine Grégoire-Besson new one :

- screw VI 2818, H M12 x 80 grade 8.8
- nyloc nut standard VJ 322, H M12

In case of safety bolt shearing :

- Raise plough so that it does not touch the ground.
- Remove all broken parts.
- Pivot bottom to line up holes and insert new safety bolt.



IMPORTANT : respect safety bolts specifications. Only use certified genuine Grégoire-Besson spare parts.

8.5. SKIMMER ADJUSTMENT

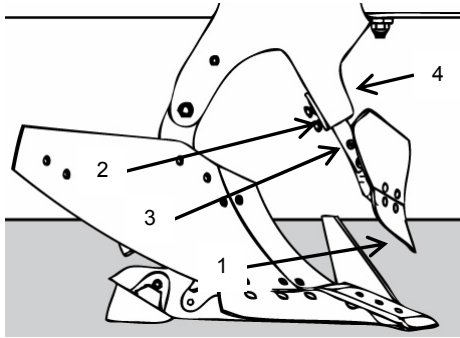

Skimmers provide good trash coverage. They are protected by a shear bolt safety device. Grégoire-Besson skimmers have been specially designed to be adjustable by an operator alone in the field.

8.5.1. Shear bolt safety device

Each skimmer is protected by a shear bolt. When hitting an obstacle, this bolt would break for skimmer to raise up.

In case of bolt shearing

- Remove all broken parts
- Install a new safety bolt

=> standard : screw ref. VI 28 08, H M12x45, grade 8.8
nut ref. VJ 322

8.5.2. Skimmer height adjustment

In general, skimmer share (1) should work the ground for half of its height to be efficient (refer to picture).

Guideline for adjustment

- Skimmer height adjustment is linked to ploughing depth, so it shall be checked after each ploughing depth changing.
- If skimmer is set too high : there is a plugging risk behind it, if there is still too much residue on the surface.
- If skimmer is set too low : there is a plugging risk ahead it, if there is too much material coming in. In this case, plough is hard to pull.

=> Both situations lead to poor trash coverage.

Adjustment procedure

- Loose the two pointed screws (2).
- Move skimmer arm (3) through its mounting bracket (4) to reach the desired height.
- Tight both pointed screws (2) inside marks of arm (3).
- In a first time, adjust 1 or 2 skimmers and make a try. If it is better, then adjust all other skimmers. If not, go back and try another adjustment.
- **All skimmers shall be set the same on both sides so that plough works evenly.**

9. MAINTENANCE

Follow recommendations given in the safety section of this manual. They are not restrictive.

9.1. GENERAL INSTRUCTIONS



Operator and user are responsible for good machine maintenance.



Inspect machine before and after each use. Repairs and service have to be done immediately so that they are not forgotten. Always leave the machine in a good state.

Cleaning the machine facilitates inspection. Check general state of machine, weldings, wheels studs, tyres, ...

Be careful with hydraulic lines : frictions may lead to excessive wearing and lines may leak. Never search a leak with your hands. Immediately replace any defective component. Spare components shall have the same characteristics.

Parts working in the ground may be sharpened and cause severe injury. Take particular care and use heavy leather gloves to remove them.

Never attempt any intervention on the machine while tractor engine is running.

Always properly secure all components before starting any maintenance operation underneath the machine.

Before using the machine for the first time, check all bolts tightness. Verify after 50 working hours and then at the beginning of each season. Pay special daily attention on :

- wheel studs tightness
- wearing parts bolts and nuts tightness in rocky or dry conditions (lots of vibrations).

Wrong waste management is a danger for environment : collect waste oil, paint removers, accumulators, worn tyres ... Bring them back to a distributor or to an authorized collector. Do not let them in the nature.

9.2. LUBRICATION

A good lubrication of all moving parts will both allow the machine to work fine and insure its long-lasting.

Grease fittings are installed on all pivot points. Grease both lubricates moving parts and chases away abrasive dust or water that could come into pivot points.

Use quality grease, type Unil – Opal MS02 or equivalent.

Always wipe grease fittings with a clean rag before introducing grease. Do not hesitate to change any worn or broken grease fitting. Check for good grease course.

Remove all grease accumulation around grease fittings or moving parts.

Refer to grease fittings placement on the following drawing. Grease every 50 working hours on a regular use. Hard or intense conditions would require more.

The best is to grease regularly with regular quantity. Do not over grease.

GREASE FITTINGS ON WHEEL

- 2 on turn over slide
- 1 on wheel hub
- 1 on wheel pivot point

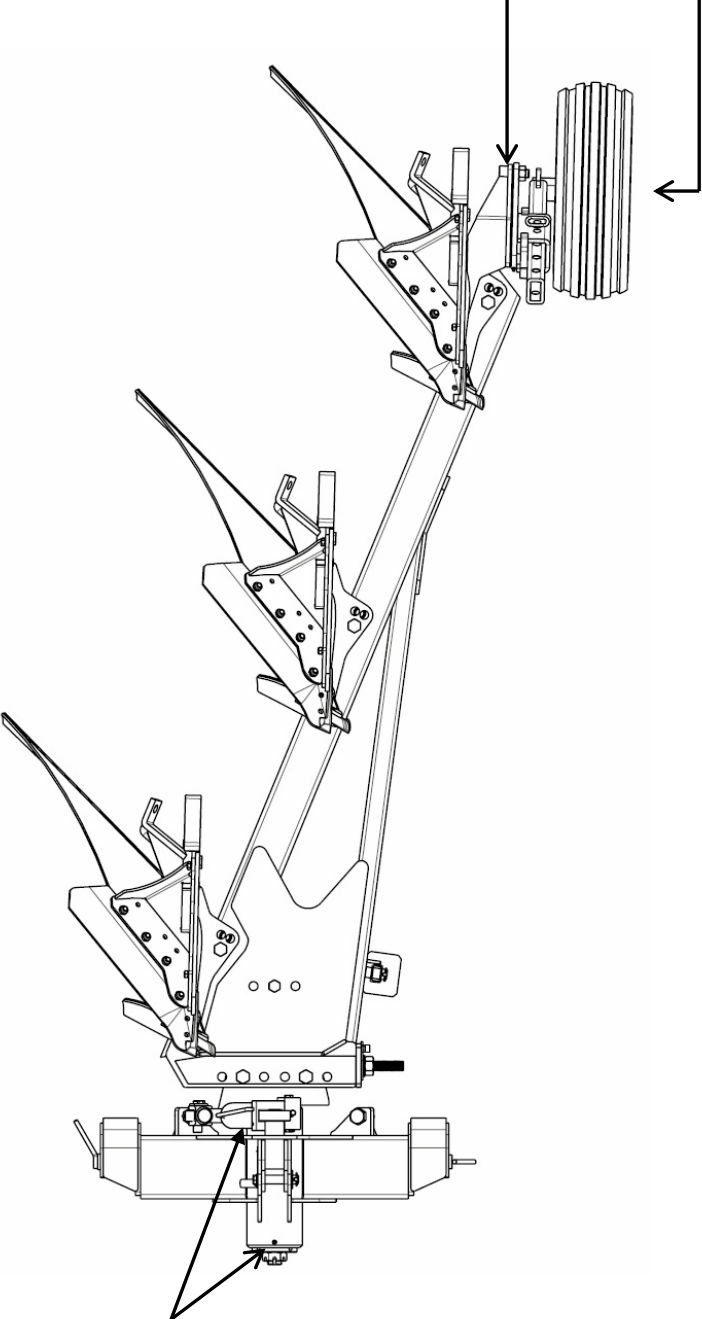

GREASE FITTINGS ON HEADSTOCK

- 2 around shaft
- 1 on each end of turn over ram

9.3. SPARE PARTS

Genuine Grégoire-Besson parts have been specially designed and developed. Only the use of these parts will ensure proper fit, longevity and field quality work of the machine.



Using any other spare part than certified from Grégoire-Besson will void warranty.

Changing wearing parts too late may be cause of poor quality work (penetration troubles, poor mixing ...) and may damage structure parts°.

9.4. WORKING BOTTOMS MAINTENANCE

Protect all parts working into the ground (mouldboards, shares, shins, disc blades) from rust whenever the plough is not used by applying a light coating of oil or grease.

While working in sticky grounds, even for a short stop, cover mouldboard with a coat of light oil (WD 40 in spray).

For longer stops, heavier oil will stay longer on mouldboards. Dry spray type graphite also, this one being removed faster.

9.5. STORAGE SAFETY

- Before detaching the machine for storage, make sure ground is clean, flat and firm enough.
- Use parking stand and all other locking devices to prevent from any unforeseen movement during detachment or later on.
- Block machine wheels to avoid any unforeseen movement.
- During storage, wheels shall not carry any weight.
- NEVER detach machine in raised position.
- Remove pressure from hydraulic circuit (engine shut off, shake hydraulic control lever in the cab).
- Store machine away from human activity.
- Store machine in a dry and dust free area (shed). Protect ram rods that cannot be retracted from rust using grease or oil.

CAUTION : never let children play around farm equipment.

10. QUICKLY STARTING - GB Line Prima

Take all precautionary measures. Respect safety recommendations.

PREPARING THE TRACTOR

- 1. Check tyre pressure**
It should be the same on both sides on each axle.
- 2. Adjust tractor hitch levelling**
Set lift links length for tractor hitch to be perfectly level with the ground.
Arms shall be long enough so that working at desired depth there is still 30 mm chrome visible on lift ram.
- 3. Adjust lift links lateral sway**
Working position lateral sway 2 to 5 cm

HITCHING

- 4. Attach lower links**
- 5. Attach top link**
- 6. Make sure there are no interferences between machine and tractor from raised position to working position**
There should be no contact between tractor arms and machine yoke hitch from raised position to working position.
- 7. Connect hydraulic turn over circuit**
- 8. Transport / working positions**
Transport position raised machine, top link in fixed hole to prevent chocks
Working position top link in a slot, higher on machine side than on tractor side
- 8. Set working width**
Set individual bottoms' working width and main frame on shaft support according to tractor inter tyre distance and desired working width

FIRST PASS

- 9. Adjustment alignment**
Top link shall be lined up with tractor.
- 11. Adjust + / - working depth with wheel height**

SECOND PASS

- 12. Adjustment alignment**
- 13. Front to rear levelling**
Top link shall be positioned higher on machine side than on tractor side and shall be free in the slot while ploughing (adjust length).
Adjust both tractor hydraulic lift height and wheel height so that plough works in horizontal position at desired depth.
Check draft control adjustment and visible chrome visible on lift ram (30 mm minimum).
- 14. Side to side levelling**
Elements shall be perpendicular with the ground.

MAINTENANCE

- 15. Follow recommendations given in this manual according to lubrication and maintenance of the machine**

NOTES

GRÉGOIRE  **BESSION**

**48230 MONTFAUCON-MONTIGNÉ-SUR-MOINE
FRANCE**

**TÉL. (+33) (0)2 41 64 72 67
FAX (+33) (0)2 41 64 67 73**

GRÉGOIRE-BESSON UK

Bourne Road, Carlby - STAMFORD Lincs PE8 4 NG – ENGLAND
phone (44) 01 778 580 223 - Fax (44) 01 778 580 645

GRÉGOIRE-BESSON CANADA INC

4480, Rue Martineau - ST-HYACINTHE (P. Québec) - CANADA J2R 1V1
TÉL. (1) 450 788 56 15 - FAX (1) 450 788 56 28

GRÉGOIRE-BESSON POLSKA

Ruda 12 - PL - 6469 ROGOZNO – TÉL / FAX (48) (67) 261 87 78

ООО «ГРЕГУАР-БЕССОН ВОСТОК»

Россия 308006 г. Белгород,
ул. Корочанская, 132а
Тел/факс: +7(4722) 58 70 36, 58 70 35
E-mail: info@gbvostok.ru
www.gregoire-besson.com

法国格力格尔 - 贝松公司北京代表处
北京市朝阳区延静里中街3号长信大厦220室
邮编：100025

WEB : www.gregoire-besson.fr **E.MAIL** : Contactfr@gregoirebesson.fr