

GRÉGOIRE  **BESSON**

R W 9

**Fully mounted reversible plough
Hydraulic variable width**

OPERATOR'S MANUAL MAINTENANCE INSTRUCTIONS



GRÉGOIRE-BESSON S.A.

Rue Victor Grégoire
49 230 MONTFAUCON – MONTIGNÉ
France

Phone : 33 (0) 2 41 64 72 67
Fax : 33 (0) 2 41 64 67 73

Web : www.gregoire-besson.com
Email : Contactfr@gregoirebesson.com

Original version
November 2009

TABLE OF CONTENTS

1. INTRODUCTION	4
PRODUCT IDENTIFICATION	4
2. SAFETY INSTRUCTIONS	5
2.1. SAFETY STICKERS	5
2.2. SAFETY WHILE ATTACHING AND DETACHING	7
2.3. SAFETY WHILE CONNECTING HYDRAULIC LINES	7
2.4. SAFETY WHILE OPERATING MACHINE	7
2.5. SAFETY FOR MAINTENANCE	8
2.6. SAFETY FOR ON HIGHWAY TRANSPORT	8
3. MACHINE DESCRIPTION	9
3.1. IDENTIFICATION VIEWS	9
3.2. TECHNICAL SPECIFICATIONS	10
3.3. DIMENSIONS AND WEIGHTS	11
3.4. LIGHT AND SIGNS KITS	11
3.5. HEADSTOCK RHAD 150	12
<u>3.5.1. Hitch pins locked in rotation</u>	12
<u>3.5.2. Activ'+ suspension on top link</u>	12
<u>3.5.3. Hydraulic side to side levelling</u>	12
<u>3.5.4. Simple setting to transport position</u>	13
<u>3.5.5. Shaft Ø 140 mm</u>	13
3.6. HEADSTOCK TO MAIN FRAME LINKAGE	13
3.7. REAR FRAME "Z" DESIGN	13
3.8. OFFSET LEG ELEMENTS	14
3.9. WORKING WIDTH	14
3.10. THE BOGIE LATERAL DOUBLE WHEEL	15
3.11. SAFETY DEVICES	15
<u>3.11.1. Shear bolt safety device type « BR9 »</u>	15
<u>3.11.2. Non-Stop Hydraulic safety device type « Y » and « Z »</u>	16
4. PREPARING THE TRACTOR	17
4.1. REQUIRED HORSE POWER	17
4.2. TRACTOR WHEELS	17
<u>4.2.1. Tractor tyres</u>	17
<u>4.2.2. Distance between tractor tyres</u>	17
4.3. FRONT END WEIGHTING	17
4.4. LIFT LINKS LENGTH	18
4.5. POSITIONING STABILIZERS	18
4.6. TOP LINK	18
5. ATTACHING AND DETACHING	19
5.1. ATTACHING MACHINE TO TRACTOR	19
<u>5.1.1. Tractor equipped with tie rods lower links</u>	19
<u>5.1.2. Tractor equipped with automatic hooks lower links</u>	19
<u>5.1.3. Hitching top link</u>	20
5.2. DETACHING THE MACHINE	20

6. HYDRAULIC CONNEXIONS	22
6.1. REQUIRED HYDRAULIC REMOTES	22
6.2. REQUIRED HYDRAULIC PRESSURE	22
6.3. HYDRAULIC CONNECTIONS	22
6.4. HYDRAULIC AUTOMATIC VALVE TYPE RA6-2M-2M	23
6.5. CONTROL BOX	25
<u>6.5.1. Installing hydraulic control box</u>	25
<u>6.5.2. Using hydraulic control box</u>	25
<u>6.5.3. Control box particularities</u>	26
6.5.3.1. Function inactivity	26
6.5.3.2. Choosing first active function when switching ON	26
7. PREPARING THE MACHINE	28
7.1. ADJUSTING POINTS LOCALIZATION	28
7.2. MACHINE WHEELS	29
<u>7.2.1. Tyre inflation</u>	29
<u>7.2.2. Wheel studs</u>	29
<u>7.2.3. Height adjustment</u>	29
<u>7.2.4. Anti-rotation axle</u>	29
7.3. PREPARING PLOUGH BOTTOMS	30
7.4. WORKING WIDTH ADJUSTMENT	30
<u>7.4.1. Principle</u>	30
<u>7.4.2. Adjustment</u>	30
7.5. ALIGNMENT ADJUSTMENT	31
<u>7.5.1. Principle</u>	31
<u>7.5.2. Adjustment</u>	31
7.6. FRONT FURROW ADJUSTMENT	32
<u>7.6.1. Principle</u>	32
<u>7.6.2. Adjustment</u>	32
7.7. ACTIV+ SUSPENSION ADJUSTMENT	33
7.8. NON-STOP HYDRAULIC SAFETY DEVICE PRESSURE ADJUSTMENT ...	34
8. TRANSPORTING	35
8.1. CHANGING TO TRANSPORT POSITION	35
8.2. CHANGING TO WORKING POSITION	36
8.3. DRIVING ON PUBLIC ROAD	36
9. FIELD ADJSUTMENT	37
9.1. FIELD UTILIZATION	37
9.2. FIRST PASS	37
<u>9.2.1. Entering into the ground</u>	37
<u>9.2.2. Alignment adjustment</u>	37
<u>9.2.3. Ploughing depth adjustment</u>	38
9.2.3.1. Tractor hydraulic hitch height adjustment	38
9.2.3.2. Tractor draft control adjustment	38
9.2.3.3. Gauge wheel height adjustment	38
<u>9.2.4. Side to side levelling = inclination adjustment</u>	38
<u>9.2.5. Front furrow width adjustment</u>	38
9.3. SECOND PASS	39
<u>9.3.1. Alignment adjustment</u>	39
<u>9.3.2. Front to rear levelling</u>	39
<u>9.3.3. Side to side levelling</u>	40
<u>9.3.4. Front furrow width adjustment</u>	40

9.4. SAFETY DEVICE ADJUSTMENT	41
<u>9.4.1. Shear bolt safety device type « BR9 »</u>	41
<u>9.4.2. Non-Stop Hydraulic safety device type « Y » or « Z »</u>	41
9.5. BOTTOM PITCH ADJUSTMENT	42
9.6. SKIMMER ADJUSTMENT	43
<u>9.6.1. Shear bolt safety device</u>	43
<u>9.6.2. Skimmer height adjustment</u>	43
<u>9.6.3. Skimmer front to rear adjustment</u>	44
10. MAINTENANCE	45
10.1. GENERAL INSTRUCTIONS	45
10.2. LUBRICATION	45
10.3. SPARE PARTS	47
10.4. WORKING BOTTOMS MAINTENANCE	47
10.5. STORAGE SAFETY	47
11. QUICKLY STARTING - R W 9	48

Any use and / or reproduction of all or part of this manual without written authorization from Grégoire-Besson is strictly prohibited.

1. INTRODUCTION



READ CAREFULLY THIS MANUAL



To properly start, operate and service your equipment, follow all instructions given in this manual.

THIS MANUAL SHOULD BE CONSIDERED AS A PART OF THE EQUIPMENT AND SHOULD FOLLOW IT WHEN YOU SELL IT.

LEFT HAND SIDE AND RIGHT HAND SIDE, FRONT AND REAR are determined looking from equipment towards tractor when in work.

ALL INFORMATIONS, PICTURE, SPECIFICATIONS in this manual are based on the newer information available at the time of publication. Pictures and drawings might not represent standard equipment and show optional attachments.

Manufacturer reserves right to make any changes at all time **without any obligation to notice or to modify any delivered or already sold machine.**

If the machine has been modified in any way from the original design without written agreement from Grégoire-Besson, the manufacturer does not accept any liability for injury or warranty. Warranty would become void.



This symbol is used in the following manual to **catch your attention on warnings concerning your safety.**

So please when you see it in this manual or on the equipment, **strictly follow given information.**

Grégoire-Besson equipments are exclusively designed to be used by professionals for regular farm tillage in farmed fields. Manufacturer shall not be responsible for damage or injury resulting from any other use.

PRODUCT IDENTIFICATION

Please record here purchasing date, model and serial number of your equipment (refer to identification plate on hitch). Always refer to these information to get prompt and good service.

Purchasing date :

Model :

Serial number :

Salesman's phone :

2. SAFETY INSTRUCTIONS

2.1. SAFETY STICKERS



Reference : UI 1980

READ OPERATOR'S MANUAL

Read operator 's manual and safety instructions before starting the use of your equipment and follow them while using.



Reference : UI 1978

STAY IN A SAFE POSITION

Do not climb on the machine. Do not strand between machine and tractor.



Reference : UI 127

MOVE AWAY FROM THE MACHINE

Danger in the working area, stay clear from the machine.



Reference : UI 126

UNFOLDING AREA

Stay clear of equipment when folding or unfolding.



Reference : UI 131

SECURE THE MACHINE BEFORE ACTION

Always install all lockup devices to secure machine before any intervention on it.



Reference : UI 1979

MOVING PARTS

Always stay far away from parts in movement.



Reference : UI 128

HYDRAULIC LEAK AND MAINTENANCE

Caution, high pressure fluids can cause injury. Follow safe practices.



Reference : UI 1981

MACHINE UNFOLDING

Never stand under machine lateral sections.
Always store machine unfolded.

Positioning safety stickers on the machine

When cleaning the machine, do not damage stickers.
Replace any damaged or missing sticker.

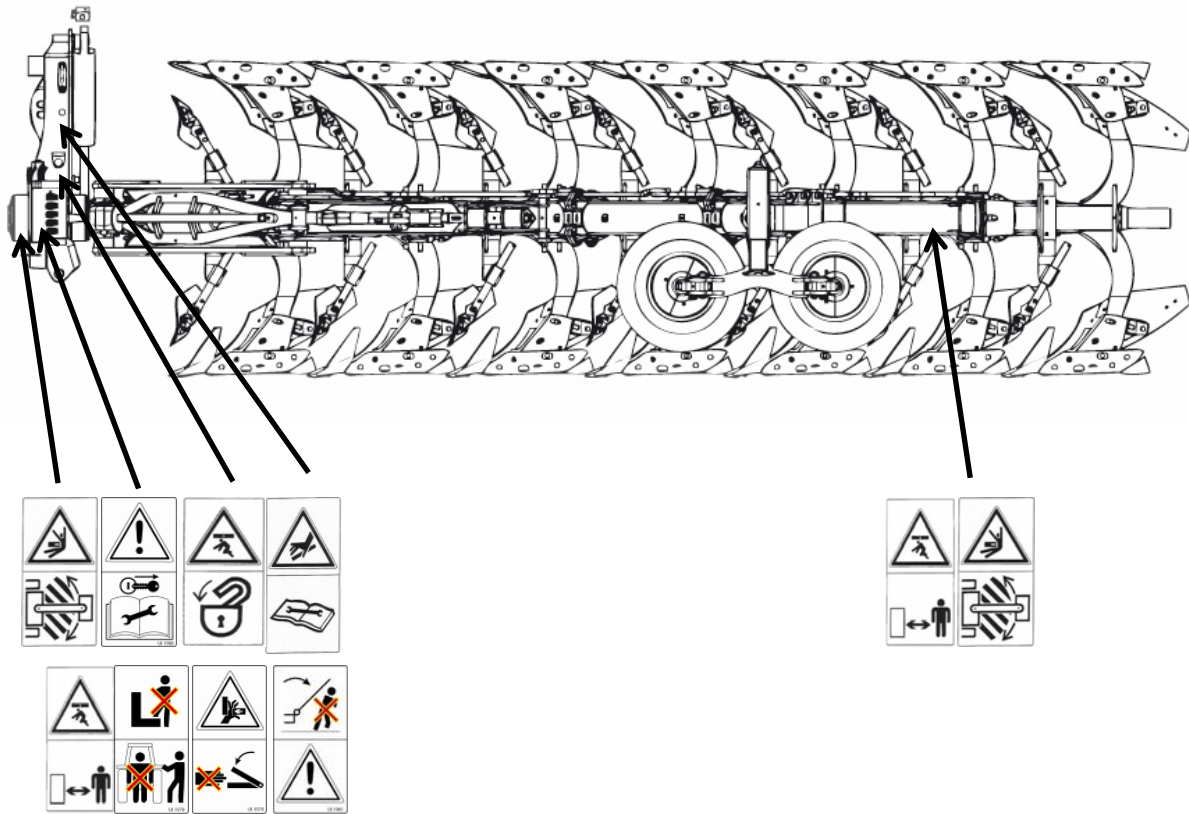

2.2. SAFETY WHILE ATTACHING AND DETACHING



- Do not let **anyone to stand between the machine and the tractor** when you back up to hitch.
- Before leaving the tractor to hitch or unhitch, set tractor parking brakes.
- Never attempt to attach the machine if pins, tractor hitching balls, tractor drawbar, or machine linkage are worn, cracked or not compatible.
- Completely lower the machine to the ground before unhitching. Make sure it is on a level and firm surface.
- Remove pressure from hydraulic lines before disconnecting them.
- Before leaving the machine for storage, make sure it is in a safe place and that there is no risk to damage whether anything or anyone.

2.3. SAFETY WHILE CONNECTING HYDRAULIC LINES



- Hydraulic circuit might be highly pressurised.
- **Never use your hands to locate a hydraulic leak.** Hydraulic fluids escaping under pressure have sufficient force to penetrate the skin, causing severe injury. In case of any injury, **see a doctor immediately.**
- For equipments loaded with several hydraulic connectors, **make logical and appropriated connections.**
- Before connecting hydraulic circuit, **make sure that there is no pressure on both sides (tractor and machine).**
- Regularly check hydraulic lines and connections. **Replace any damaged or leaking component** by an original part with the same specifications.
- Before any intervention on hydraulic circuit, **lower machine to the ground and release pressure moving control lever in the tractor's cab.**

2.4. SAFETY WHILE OPERATING MACHINE

- **Never attempt** any intervention on the machine while it is in motion.
- Do **not** allow anyone to **stand close to pivot points** : bottoms safety device (shearing bolt or non-stop), all pivoting linkage.
- Wear close **fitting clothing** and **appropriate safety devices** for the job you have to do (heavy leather gloves, safety shoes, earplugs, ...).
- Do not allow anyone to stand close to the machine.
- Do not attempt to do any adjustment if you have not perfectly understood its procedure.
- Always use tools or equipments appropriate to the job you are doing. All Grégoire-Besson equipments are metric standards.
- Learn how to operate your machine and how to use its controls. Do not let anyone operate without instruction.
- Do not extend turnbuckle adjusters too much to avoid any threads damaging or intempetive pulling out.
- Only one person (the operator) should be in the tractor's cab when it is in operation. **No one on the machine while working or travelling on the road.**
- When earring or feeling unusual vibrations, stop the machine. Find the problem and solve it before starting operating again.



If your machine is equipped with a hydraulic folding mechanism, **always use it from tractor's cab**, once you are sure that folding area is free from spectators or obstacles.

2.5. SAFETY FOR MAINTENANCE



- Maintenance area shall be **clean, dry, with enough light and ventilation**.
- For any intervention on the machine in raised position, **always securely support all components** before starting maintenance.
- **Maintenance operations on elements under pressure or under tension** (resorts, accumulators, ...) require specific procedure and equipments. **Only qualified persons shall perform them in appropriate conditions.**
- After servicing remove all tools, components and parts you used.
- Regularly **check tightness of wheel studs, wearing parts bolts, and all other bolts and nuts.**
- **Always use genuine parts corresponding to manufacturer's technical specification requirements.**

2.6. SAFETY FOR ON HIGHWAY TRANSPORT



FOR YOUR OWN SAFETY AND THE ONE OF THE OTHER, RESPECT THE FOLLOWING RULES :

- All Grégoire-Besson equipments shall be used **complying with area's current rules and laws** concerning **safety instructions, accident prevention and provision of Highway Code**.
- Before road transport, always **check for wheels studs** and wheels mounting brackets carriage bolts **tightness** ; **check tyres general state and pressure** : do not drive with low pressure, cuts or damaged tyres or rims.
- **Use all devices required by your area's current laws** (lights, reflectors, signs, ...). They might be removed during field operation to prevent from any damage. It is the operator's responsibility to comply with current law and to follow its evolutions.
- Regularly check hitching pins, change them if necessary. Tractor's ball joint may also wear, do not hesitate to replace them with new ones having at least Waltersheid fabrication quality.
- Drive **at reasonable speed** complying with local laws **to always keep control** of tractor and equipment. Pay special attention on irregular or rough roads. **Do not attempt to drive down a hill faster than it could be possible to drive it up.**
- Tractor used for road transport shall have the same power rating and weight as the one used for field operations.
- **Never attempt any manoeuvre if area is not free from spectators.**
- If your machine is equipped with a **folding mechanism** (manual or hydraulic), **use it making sure folding area is free from spectators** and obstacles.
- Follow all **safe driving practices** when travelling, moreover **on corners, rough or narrow roads**.
- When **leaving tractor** even for a short period, **shut off engine, remove ignition key and set parking brakes**.
- Forbid anyone to stand between tractor and machine or on the machine travelling on the road.

3. MACHINE DESCRIPTION

3.1. IDENTIFICATION VIEWS

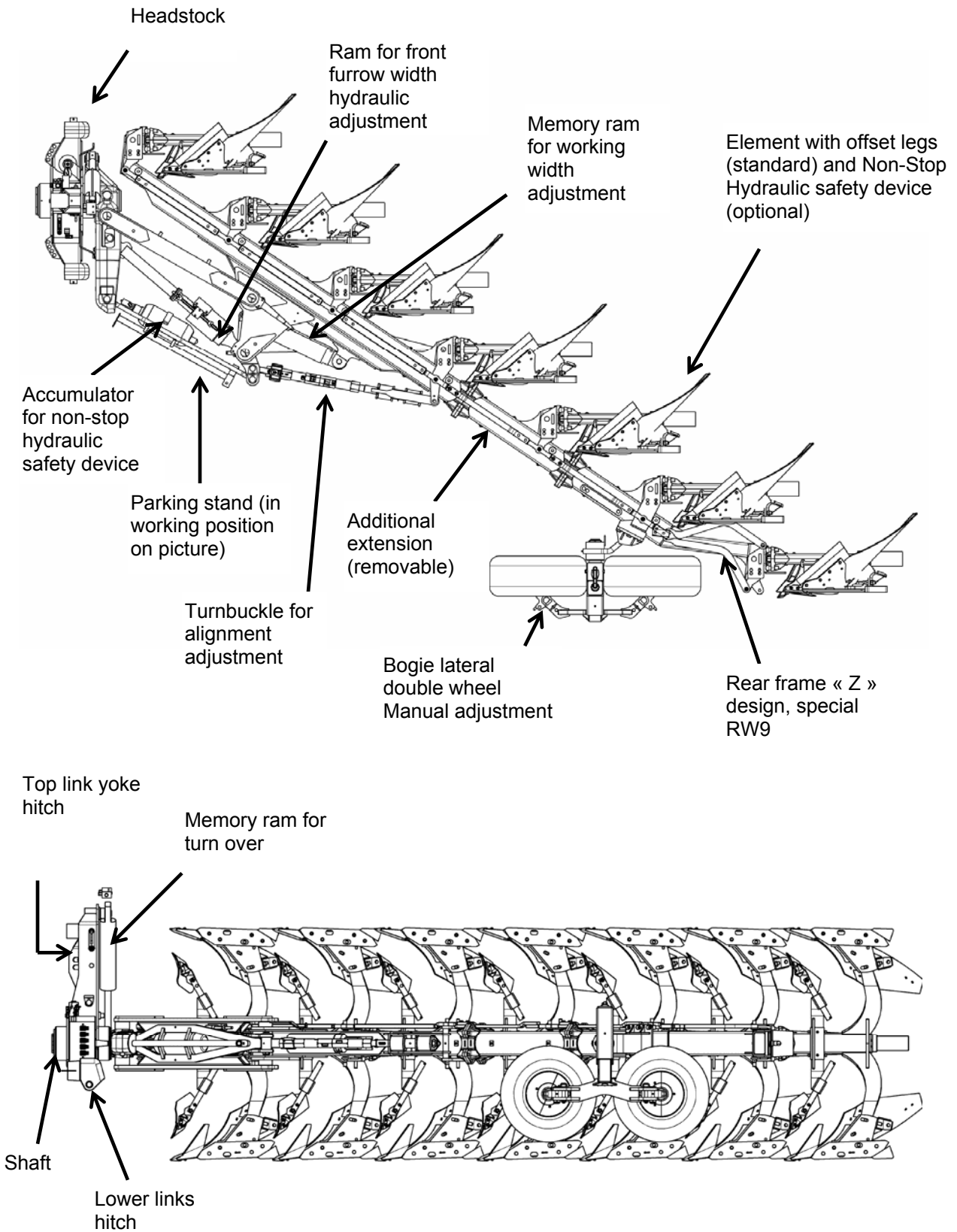

3.2. TECHNICAL SPECIFICATIONS

Specification	Standard equipment	Optional equipment
Turn over	<ul style="list-style-type: none"> Hydraulic with memory ram type RHAD 150 Side to side levelling with turn over memory ram Automatic plough alignment before turn over (with hydraulic working width memory ram) 	
Frame	<ul style="list-style-type: none"> Main frame 180 x 180 mm with possible modular arrangement of bottoms Rear frame "Z" design Moulded steel plates for linkage 	
Working width	<ul style="list-style-type: none"> Hydraulically adjustable with memory ram from 12" to 20" (= 30 to 50 cm) 	
Alignment adjustment	<ul style="list-style-type: none"> With mechanical turnbuckle with shock absorbers 	
Front furrow adjustment	<ul style="list-style-type: none"> With hydraulic ram, adjustable on the go 	
Inter body clearance	<ul style="list-style-type: none"> 90 cm (= 35") 	<ul style="list-style-type: none"> 100 cm (= 39")
Point to point height	<ul style="list-style-type: none"> 170 cm 	<ul style="list-style-type: none"> 180 cm
Safety device	<ul style="list-style-type: none"> Shear bolt (B) Non-Stop Hydraulic (Y) 	<ul style="list-style-type: none"> Non-Stop Hydraulic reinforced (Z)
Hydraulic requirements	<ul style="list-style-type: none"> 1 DA direct plug in tractor spool : turn over + automatic realignment with memory ram 1 DA direct plug in tractor spool : working width adjustment 1 DA plug in control box : front furrow hydraulic adjustment side to side levelling adjustment transport position lock / unlock bogie wheel hydraulic depth control (option) 1 free return to release pressure from hydraulic bloc valve 	
Wheel	<ul style="list-style-type: none"> RLBM double lateral bogie wheel bogie in working configuration carrier in transport configuration tyre 11.0/65x12 or 320x60-12 mechanical turnbuckle for depth control adjustment Wheel flanges 	<ul style="list-style-type: none"> Hydraulic depth adjustment RLBH
Bottoms	<ul style="list-style-type: none"> 16" self sharpening shares with reversible points or square bar point 35 mm Mouldboards helicoïdal short (H4 / H5), or American (3A / 5A), or Cylindrical standard (C 14 / C 16) or Cylindrical flat (P 14 / 16) Landside wearing plates Pitch adjustment 	<ul style="list-style-type: none"> Choice for mouldboards : helicoïdal long, plastic, slattered Mouldboard extensions Choice for share width : 14", 16", 18"
Wearing parts accessories		<ul style="list-style-type: none"> Trash covers Long knife coulters Subsoiler tine
Skimmers	<ul style="list-style-type: none"> Adjustable front to rear & up and down Shear bolt safety device Type mixed, manure or trash covers instead of skimmers 	<ul style="list-style-type: none"> Type maize, euro, universal or pasture

A large choice of options is available to improve machine's job.

Grégoire-Besson authorized dealers know area and working conditions. They may give information according to technical choices and latest equipments evolutions.

Grégoire-Besson is also represented on farm equipment shows.

3.3. DIMENSIONS AND WEIGHTS

Nb of furrows	Inter body clearance	Working width		Over all length (approx.)	Indicative weight (B)	Indicative weight (Y)	Indicative weight (Z)
5	90 cm	12" à 20 "	1.5 à 2.5 m	5.20 m	2 800 kg	2 950 kg	3 000 kg
6		=	1.8 à 3.0 m	6.10 m	3 000 kg	3 180 kg	3 240 kg
7		30 à 50 cm	2.1 à 3.5 m	7.00 m	3 200 kg	3 410 kg	3 480 kg
5	100 cm	12" à 20 "	1.5 à 2.5 m	5.60 m	2 850 kg	3 000 kg	3 050 kg
6		=	1.8 à 3.0 m	6.60 m	3 060 kg	3 240 kg	3 300 kg
7		30 à 50 cm	2.1 à 3.5 m	7.60 m	3 270 kg	not available	

Dimensions and weights are indicative and subject to variations according to equipments and options.

Note : after use, ground or residue accumulations may increase machine's weight.

3.4. LIGHT AND SIGNS KITS

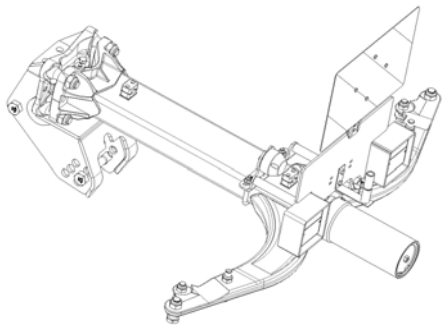

Light and signs kits are available for all Grégoire-Besson equipments. Contact an authorized dealer.

Note : it is the operator's responsibility to comply with local current applicable law before any transport on public road.

3.5. HEADSOTCK RHAD 150

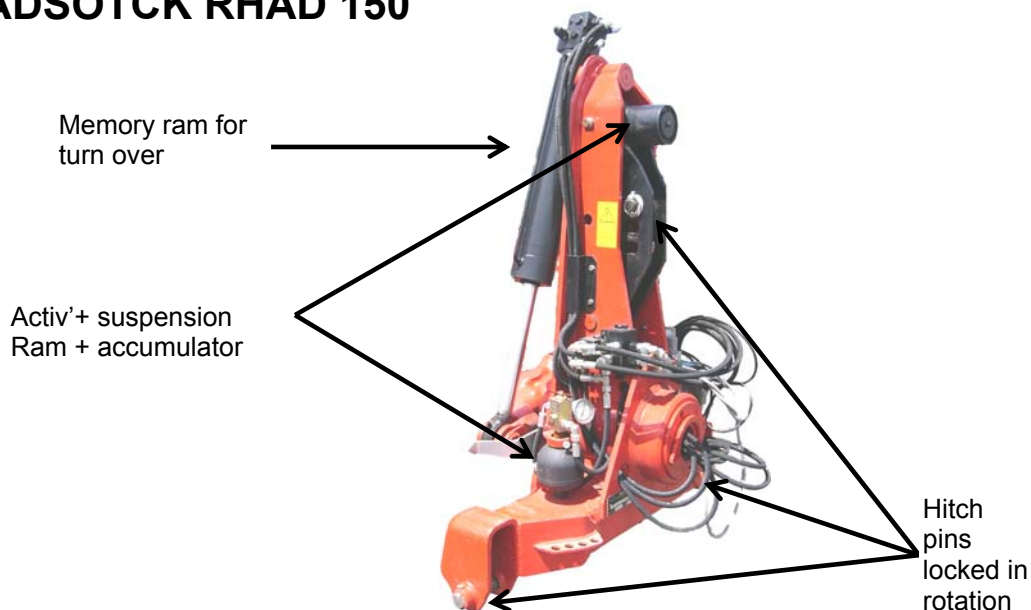

3.5.1. Hitch pins locked in rotation

All three hitch pins are locked in rotation to prevent from any loose or wear.

3.5.2. Activ'+ suspension on top link

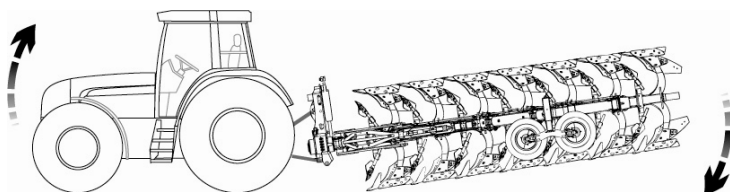

Length and weight of fully mounted equipments are source of sway phenomenon. This appears using a RW9, when the plough is in raised position during turnover or any other manoeuvre (refer to picture).

This is why Grégoire-Besson RW9 is equipped with an Activ'+ suspension on top link hitch point. This system (ram + nitrogen gas accumulator) absorbs main part of the forces responsible for sway phenomenon.

Driver's comfort is widely improved with Activ'+ used alone and / or combined with suspension systems loaded on most recent tractors (front axle and / or rear hydraulic hitch).

3.5.3. Hydraulic side to side levelling

Plough turn over is done with a memory ram, so side to side levelling (= inclination) is done hydraulically from the cab. No more stoppers to adjust on headstock. Adjustment can be done

- on the go, using hydraulic control lever : useful to open a field or working in sloping grounds
- using ram memory function : once inclination is set, it is put in memory. Plough will come back to the same position on both sides after each turn over.

Note : ram memory function may be used to detach plough with headstock in horizontal position. Manoeuvre is faster and safer. Next attaching manoeuvre will be easier too.

3.5.4. Simple setting to transport position

Transport position locking pin is hydraulically controlled from the cab.
Headstock Activ'+ suspension uses a double articulation system that allows settlement to transport position simply removing a pin. Top link does not have to be removed.
Setting to transport position is so an easy and safe manoeuvre.

3.5.5. Shaft Ø 140 mm

RW9 is equipped with a shaft Ø 140 mm with two conical bearings having the same size. This ensures strength and long lasting for the headstock.

3.6. HEADSTOCK TO MAIN FRAME LINKAGE

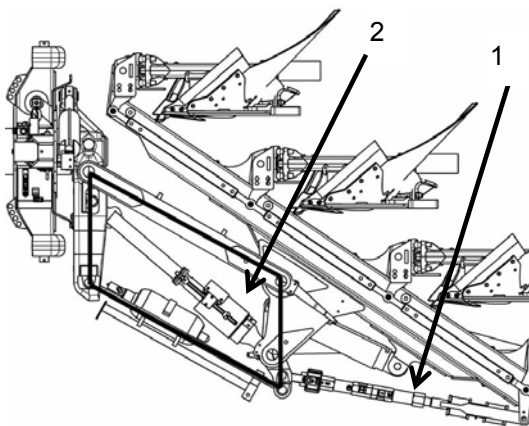

The headstock is connected to the main frame via a truth parallelogram (refer to picture).

Two independent arms allow plough adaptation to all conditions :

- alignment arm (1) : to line up the plough behind the tractor. Refer to section 7.5.
- front furrow width adjustment arm (2) : to adjust front furrow width of cut. Refer to section 7.6.

3.7. REAR FRAME “Z” DESIGN

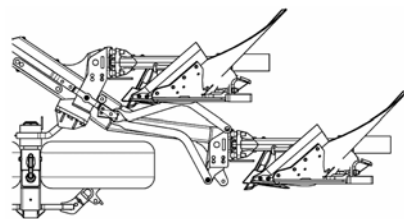

Main frame 180 x 180 mm section has been specially designed with a rear part in “Z” for an optimal gauge wheel positioning : both rear and taken out by rear furrow.

There is enough clearance to use large tractor type tyres to work in all conditions.

3.8. OFFSET LEG ELEMENTS

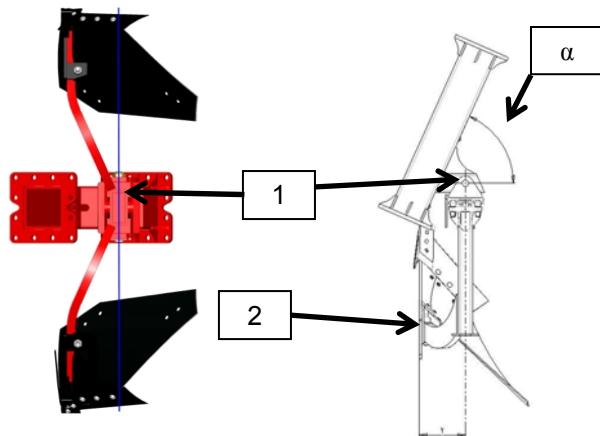

1 - Element pivot point (1) is positioned vertically to the middle of the share, for an even balance of forces.

2 - Frame angle (α) controls bottoms working width. They line up following traction line.

3 - Landsides (2) allow ploughing precision and machine stability in the ground.

These elements provide advantages :

- no needless lateral forces,
- landsides wearing reduction,
- reduced horse power requirement,
- improved capacity to loop around obstacles,
- fast machine adaptation to conditions (hydraulic variable working width),
- wheel track taken out by rear furrow.

3.9. WORKING WIDTH



Plough working width can be set at any time thanks to a memory ram. It controls a double rod mechanism positioned outside the beam and protected from shocks with rubber blocks.

- When ploughing : width of cut may be adjusted "on the go" at any time and is automatically memorized.
- When turning the plough over : realignment is done with closing to 12". Once turned over, memory ram brings plough back to its memorized working width.

Refer to 7.4. section.

3.10. THE BOGIE LATERAL DOUBLE WHEEL

The bogie lateral double wheel (Grégoire-Besson patented) is a combined wheel :



- **depth control, in bogie configuration** : pressure is shared between both wheels. First wheel track facilitates second wheel passage, so it is possible to keep working in extremes conditions. Bogie height adjustment is done by mechanical turnbuckle (RLBM) or hydraulic ram (RLBH). The two wheels are different models, it is impossible to change from one to the other,
- **transport wheel, in carrier configuration** : both wheels ensure plough stability for road transport. Rubber blocks are then useful as shocks absorbers (when plough is in 14" or 16" position).

Changing configuration is fast and easy : for each wheel remove lock pin, turn 90° around mounting bracket and put back lock pin.

Wheel positioning has been optimized :

- track taken out : wheel is "inside" the frame so that rear furrows ploughs its track,
- maximum rear position to have :

=> optimum depth regularity for rear furrow,

=> good weight transfer on tractor,

=> efficient tractor draft control.

3.11. SAFETY DEVICES

3.11.1. Shear bolt safety device type « BR9 »

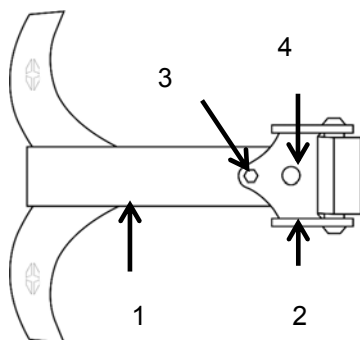

Element (1) is fixed in yoke in support (2). When hitting an obstacle, a two points breaking bolt (3) shears for the complete bottom to trip, pivoting around its articulation (4).

In case of safety bolt shearing, replace it by a new one, certified genuine Grégoire-Besson.

Point to point height	Bolt ref. 1 119 815 H M20x150, grade 8.8
170 cm	6 000 kg
180 cm	5 600 kg

Pressure on point for BR9 safety device tripping.

3.11.2. Non-Stop Hydraulic safety device type « Y » and « Z »

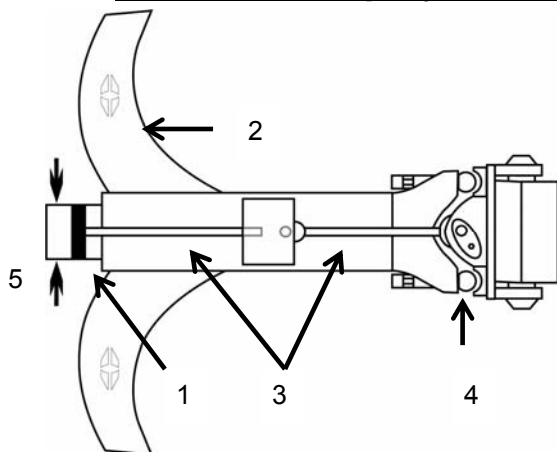

At the rear each element (2) has a safety ram (1). This ram is linked to the frame by a two parts rod (3), allowing 850 mm as ground clearance.

At the front, each element has four ball bearings (4) to hold it on the frame.

All safety rams are connected on the same hydraulic circuit also composed by a gas accumulator and a gauge to be able to check pressure at any time.

Hitting an obstacle, when pressure at the point becomes higher than pressure in the circuit, bottom will trip, sending oil into the accumulator. When

obstacle is gone, pressure at the point decreases, accumulator releases oil and bottom comes back to its position.

Pressure in the hydraulic circuit is adjustable. **Always stay in the green zone on the gauge.**

If it is necessary, there are two ways to reach higher resistance :

- using safety rams with larger diameter (5) : diameter is measured at the rear of the ram,
- using accumulator with larger pressure capacity : capacity is written on accumulator whether on a sticker or on a plate.

Note : it might be more interesting to choose an accumulator with larger pressure capacity : wider utilization flexibility, changing is fast and easy on an already delivered machine, no price difference between the two accumulators.

	Standard assembly	Optional assembly
Ram Ø on front furrow	100 mm	110 mm
Ram Ø on other furrows	90 mm	100 mm
Accumulator	6 liters - 150 bars	-

Characteristics of components for safety device non-stop hydraulic type Y and Z.

Point to point height	Safety device ram Ø	Accumulator 150 bars			
		Pressure mini : 160 bars		Pressure maxi : 200 bars	
170 cm	90 mm	860 kg	1 892 lbs	1 075 kg	2 365 lbs
	100 mm	1 110 kg	2 442 lbs	1 390 kg	3 058 lbs
	110 mm	1 390 kg	3 058 lbs	1 730 kg	3 806 lbs
180 cm	90 mm	810 kg	1 782 lbs	1 020 kg	2 244 lbs
	100 mm	1 050 kg	2 310 lbs	1 320 kg	2 904 lbs
	110 mm	1 320 kg	2 904 lbs	1 650 kg	3 630 lbs

Pressure on point for **Y type** non-stop hydraulic safety device tripping.

Point to point height	Safety device ram Ø	Accumulator 150 bars			
		Pressure mini : 160 bars		Pressure maxi : 200 bars	
170 cm	90 mm	973 kg	2 140 lbs	1 217 kg	2 678 lbs
	100 mm	1 258 kg	2 768 lbs	1 572 kg	3 460 lbs
	110 mm	1 572 kg	3 460 lbs	1 965 kg	4 323 lbs
180 cm	90 mm	925 kg	2 035 lbs	1 157 kg	2 546 lbs
	100 mm	1 196 kg	2 631 lbs	1 495 kg	3 289 lbs
	110 mm	1 495 kg	3 289 lbs	1 869 kg	4 112 lbs

Pressure on point for **Z type** non-stop hydraulic safety device tripping.

4. PREPARING THE TRACTOR

Follow recommendations given in the safety section of this manual. They are not restrictive.

4.1. REQUIRED HORSE POWER

Tractor requirements may vary according to ground and working conditions (type of soil, type of tractor, type of tyres, ...). Following data are only indicative. Ask an authorized Grégoire-Besson dealer for any further information.

Number of furrows	Medium type soils (15 to 30 % clay)	Heavy type soils (> 50 % clay)
5	170 - 200 HP	210 - 250 HP
6	190 - 220 HP	230 - 300 HP
7	220 - 250 HP	260 - 350 HP

4.2. TRACTOR WHEELS

4.2.1. Tractor tyres

Check tractor tyres general state and pressure. Pressure should be the same on both sides of the tractor for a nice drivability in the field and on the road.



IMPORTANT : inflate tyres following manufacturer's recommendations.

4.2.2. Distance between tractor tyres

Generally, using a plough with large number of bottoms, the wider is the distance between tyres, the better is the drivability.

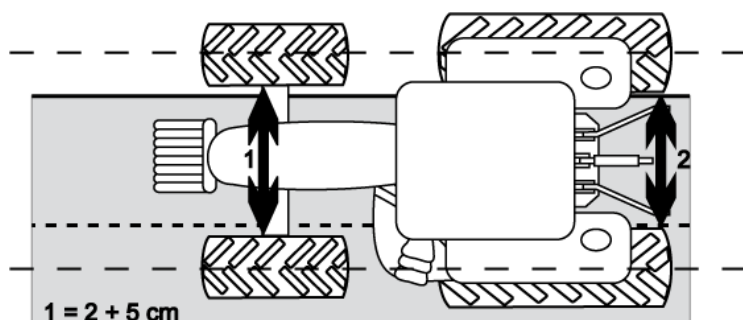

To be able to steer the tractor in the furrow, the middle of the front axle shall be lined up with the middle of the rear axle. This would also prevent from useless friction of front wheel on the furrow wall. Hydraulic ram for front furrow width of cut adjustment will allow adaptation to all conditions.

Inter tyre distance is related to the front furrow arm adjustment and to the ploughing width. In sloping fields, larger distance will provide better stability.

Minimum inter tyre distance (2) : 1.30 m.

Maximum inter tyre distance (2) : 2.35 m.

4.3. FRONT END WEIGHTING

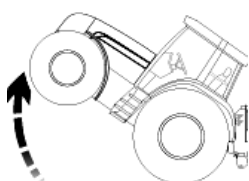

Wheels weights (front and rear) and front end weights may be required to avoid excessive slippage and to increase stability in rough and sloppy grounds.

Weights shall not be added once all slippage is eliminated. Refer to tractor operator's manual and to tractor's dealer. Follow tyre manufacturer's recommendations.

4.4. LIFT LINKS LENGTH

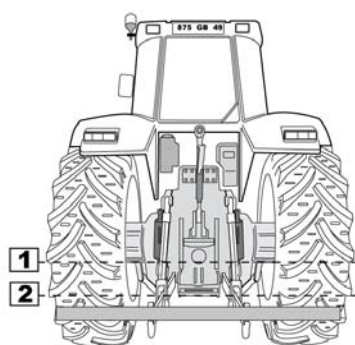

Lift link arms length determines tractor hitch levelling and lift cylinder position at working depth.

- Set lift links length so that tractor hitch is level (refer to picture).
- Set lift links length to have at least 30 mm clearance on lift cylinder rod when machine is working at desired depth. This will give adjustment possibilities for front gang depth from tractor's cab and allow efficient tractor draft control

4.5. POSITIONING STABILIZERS

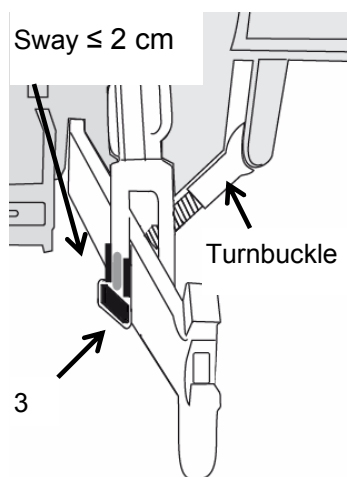

To hitch a fully mounted equipment; stabilizers shall be positioned so that :

- **in transport position** : lift links arm have **minimum sway ($\leq 1\text{ cm}$)**. This will prevent from chocks between machine and tractor during manoeuvres or transport
- **in working position** : lift links arms shall have **2 to 5 cm** loose.

If necessary, install bushings to avoid lateral movement of hitch arms on hitch pins. Always check for compatibility between hitch pins and bushings (\varnothing and length).

Note : it is easier to adjust and / or service stabilisers bolts and threads before hitching the machine.

Horizontal lift links pins (3) shall be in fixed position to avoid any loose and / or damageable shock.

4.6. TOP LINK

Before attaching the machine, make sure that thread length is the same on both sides of top link. Refer to picture, A shall equal B.

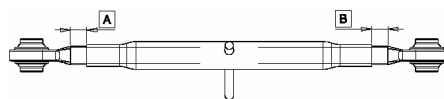

NOTE : an excess of grease inside top link tube may make it impossible to shorten. Remove grease fitting to let grease free to go out.

IMPORTANT : connection between machine and top link shall be done through a tie rod and never through an automatic hook.

- Automatic hooks sizes and designs change according to models and manufacturers and may cause interference with machine hitch in particular conditions.
- Spring shutter may block hitch ball which may wear or break. This is particularly true for hitches cat III: pin diameter is larger giving less quantity of matter for the ball becoming less strong.

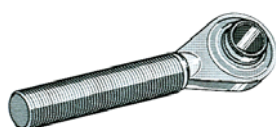

Tie rod
CORRECT

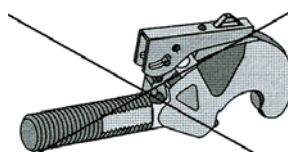

Automatic hook
DO NOT USE

5. ATTACHING AND DETACHING

Follow recommendations given in the safety section of this manual. They are not restrictive.

IMPORTANT : always make sure that hitching never leads to :

- overload : respect maximum hitch capacity
- unbalance: load tractor front end if necessary. Refer to point 4.3.

5.1. ATTACHING MACHINE TO TRACTOR

5.1.1. Tractor equipped with tie rods lower links

- Before any manoeuvre, check for diameter and length compatibility between hitch pins and tractor tie rods.
- Remove safety bolts and hitch pins.
- Back up tractor to line up tie rods and machine hitch holes.
- Install pins and secure them with their safety clips.
- If holes are difficult to line up : extend telescopic arms as indicated in tractor operator's manual. Once hitch pins are inserted and secured with their safety clips, slowly back up tractor to lock back lift arms. Check for lift arms locking.
- Hitch top link.

5.1.2. Tractor equipped with automatic hooks lower links

- Remove safety bolts and hitch pins.
- Remove balls from tractor lift link automatic hooks.
- Check for balls and pins general state and compatibility.
- Install balls on pins through lower machine hitching holes. Secure with safety bolts.
- Slowly back up tractor till automatic hooks are lined up underneath hitch balls.
- Raise tractor hitch about 5 cm above ground surface till automatic hooks are locked.
- Check for automatic hooks latch handles good locking.
- Hitch top link.



IMPORTANT : before hitching top link, **make sure to have enough clearance between machine yoke hitch and tractor lower lift links to avoid any possibility of contact from working to raised position. A second verification shall be done once machine is in the field in truth working conditions.**

Note : if headstock is not horizontal, use turn over memory ram to level it. This will make attaching manoeuvre easier and safer.

5.1.3. Hitching top link

Connexion between top link and machine has to be done through a tie rod (refer to previous section).

Once tractor lift links are correctly hooked up, check top link general state and compatibility with tie rod. Then attach top link in one of the three available slots.

Raise machine to the maximum and make sure there are no interference with tractor. Final top link adjustments (length and position) will be made in the field.

Put parking stand in working position : remove safety clip and pivot it into horizontal position. Do not forget to install safety clip back.



IMPORTANT : make sure to have enough clearance between machine yoke hitch and top link to avoid any contact from working to raised position. A second verification shall be done once machine is in the field in truth working conditions.

Connect hydraulic hoses and control box.

5.2. DETACHING THE MACHINE

Before detaching, make sure that ground is flat and firm enough to support the machine. Use safety blocks to support machine components if necessary.



DANGER : do not let any part of your body underneath the machine when lowering it to the ground. Crushing may lead to death.

Proceed in the logical attaching opposite way :

- 1) Put machine in working position = it shall stay on its bottoms L.H. or R.H. side
- 2) Put stand in parking position = vertical
- 3) Put headstock in horizontal position using turn over memory ram, this will help for both detaching and next attaching
- 4) Completely lower the machine to the ground,
- 5) Detach top link
- 6) Remove pressure, disconnect hydraulic lines and control box (which can be totally removed from the machine if stored outside)
- 7) Detach lower lift links

Always operate with care.

NOTES

6. HYDRAULIC CONNEXIONS

Follow recommendations given in the safety section of this manual. They are not restrictive.

6.1. REQUIRED HYDRAULIC REMOTES

- **1 DA for turn over + automatic realignment** with width adjustment memory ram + **Activ'+ headstock suspension pressure settlement** (independent circuit, valve shall be opened to adjust it) + **NSH safety device pressure adjustment** (independent circuit, valve shall be opened to adjust it)
- **1 DA for working width** adjustment
- **1 DA for hydraulic control box :**
 - ⇒ **front furrow width** adjustment,
 - ⇒ **inclination** adjustment (= side to side levelling),
 - ⇒ **transport position pin locking / unlocking**,
 - ⇒ optional hydraulic bogie wheel **RLBH depth control**,
 - ⇒ **free return to tractor** to release pressure when changing function with hydraulic box in the cab. Without this free return, oil may remain under pressure in a circuit. It may look for evacuation through another circuit. This could lead to unforeseen effects as transport position unlocking.

6.2. REQUIRED HYDRAULIC PRESSURE

Required tractor hydraulic pressure is 180 to 200 bars.

6.3. HYDRAULIC CONNECTIONS

- Always wipe hydraulic couplers with a clean rag on both tractor and machine sides before connecting circuits.
- Always check for machine hydraulic connectors and tractor remotes compatibility.
- Logically connect hydraulic lines for the user :
 - ⇒ Put most frequently used functions on closest lever
 - ⇒ Watch for the way hydraulic flow is delivered : pull the lever to put machine in transport position (raise up / fold), push it to put machine in working position (lower / unfold).
 - ⇒ Identify hoses using colour collars and signs (+ to extend rods, - to retract them).
 - Check for hydraulic hoses length : too short they may break during sharp turns, too long they may interfere with tractor lift arms or tyres.

In case of any problem, do not hesitate to contact an authorized Grégoire-Besson dealer.

6.4. HYDRAULIC AUTOMATIC VALVE TYPE RA6-2M-2M

Plough is equipped with an hydraulic automatic valve type RA6 - 2M - 2M to control turnover cycle = realignment + turnover. It is situated on headstock. Realignment is made through working width.

Principle

When driver acts on hydraulic control lever in the cab, turnover operation goes on following hereafter cycle :

- **realignment** through working width : plough comes to 12", its minimal width
- **turnover** ram retracts and extends, it comes back to its previously set position = same axle to axle distance (memory ram)
- **opening back** plough opens to its previously set working width (memory ram).

Connection drawing

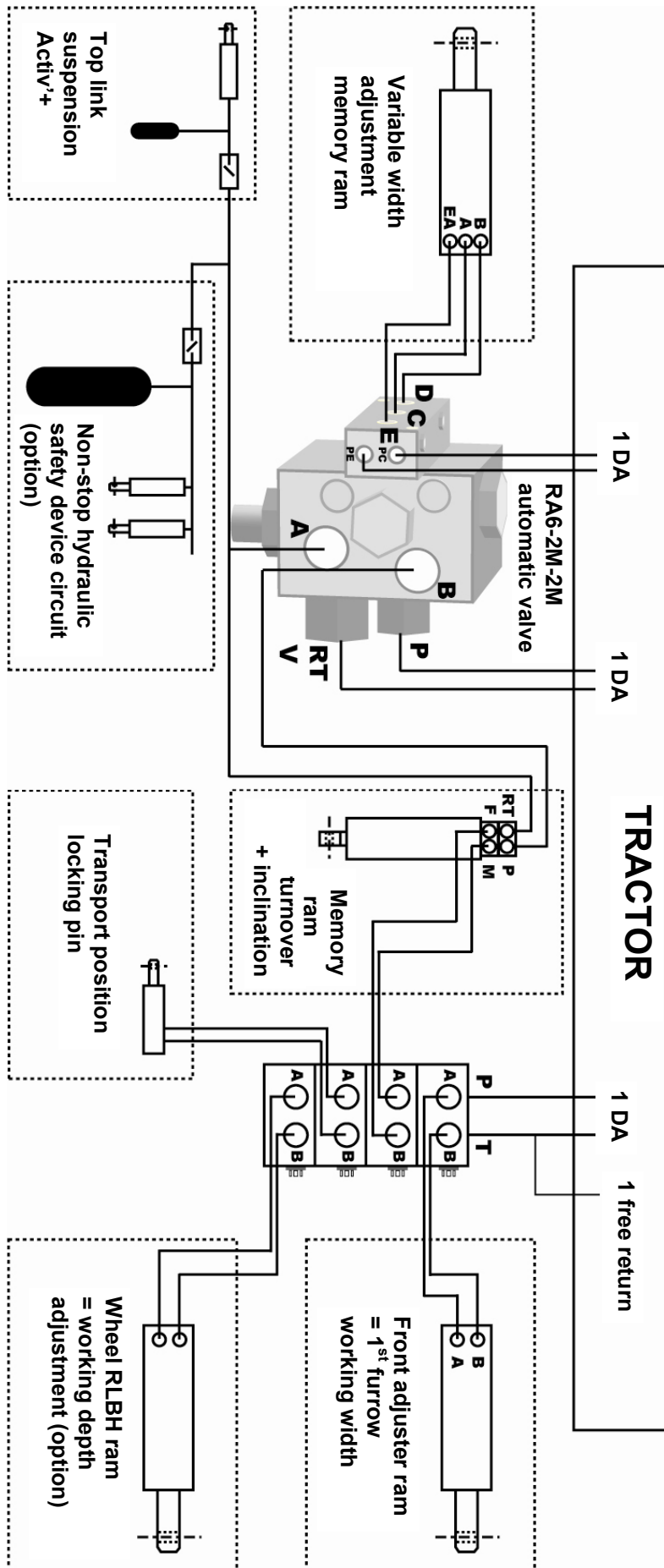

6.5. CONTROL BOX

6.5.1. Installing hydraulic control box

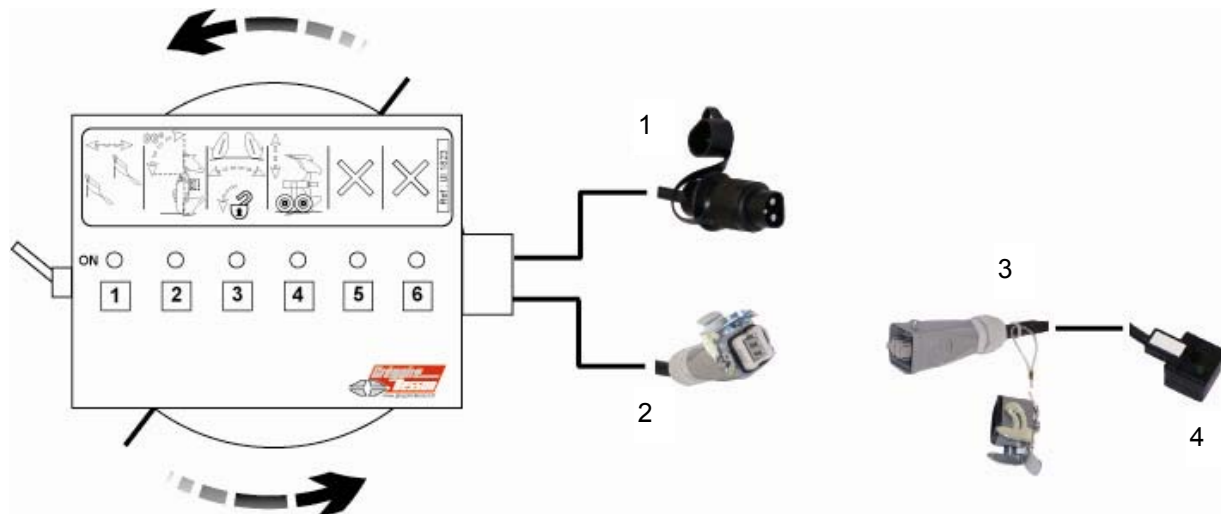

Properly fix control box in the cab (quarter turn on suction pad mounting bracket).

Both wires shall be properly connected :

- black wire (1) : for control box electric supply (european standard, DIN 3 plug and sockets connector). Most tractors are equipped with a corresponding female plug in the cab. On several tractors, this plug is full time on : so to avoid battery discharging, while not in use, put control box switch on OFF position,
- grey wire (2) : for control box connection to extension (3), and then to electro valves (4) situated on plough headstock+.

Notes :if plough has to be stored outside, hydraulic control box can be completely removed (disconnecting both wires) and installed back for the following season,

to check for correct plugging, remove block valve protection plate on the L.H. side of the headstock. On each plug (4), DIN 4 plugs-and-sockets european standard, a LED is ON when correctly connected.

6.5.2. Using hydraulic control box

- Put switch on « ON » position (refer to picture here above).
- Function 1 shall be active (LED is on to confirm).
- Push on the button corresponding to the desired adjustment to do :

=> **button 1 = front furrow width** to adjust front furrow ploughing width. Refer to section 9.3.4.

=> **button 2 = inclination** to adjust side to side levelling. Refer to section 9.3.3.

=> **button 3 = locking pin** to put / remove transport position safety locking pin. Refer to section 8.1.

=> **button 4 = RLBH wheel** to adjust optional RLBH height. Refer to section 9.3.2.

- Then act on hydraulic control lever to perform desired adjustment.

6.5.3. Control box particularities

6.5.3.1. Function inactivity

To inactivate a function :

- press on corresponding button and keep holding till LED switches OFF,
- function is inactive when LED is OFF,
- confirm inactivation by pressing on button 1.

To re-activate a function :

- press on corresponding button and keep holding till LED switches ON,
- function is re-active when LED is ON,
- confirm inactivation by pressing on button 1.

Note : function 1 cannot be inactive

6.5.3.2. Choosing first active function when switching ON

When switching control box ON, first active function may be

- function 1 (standard settlement),
- last function active when switching off control box.

To change control box configuration, press button 1 for several seconds.

NOTES

7. PREPARING THE MACHINE

Follow recommendations given in the safety section of this manual. They are not restrictive.

7.1. ADJUSTING POINTS LOCALIZATION

Find adjusting points and check their lubrication and work. Doing this checking task close from a machine shop is better than doing it in the field.

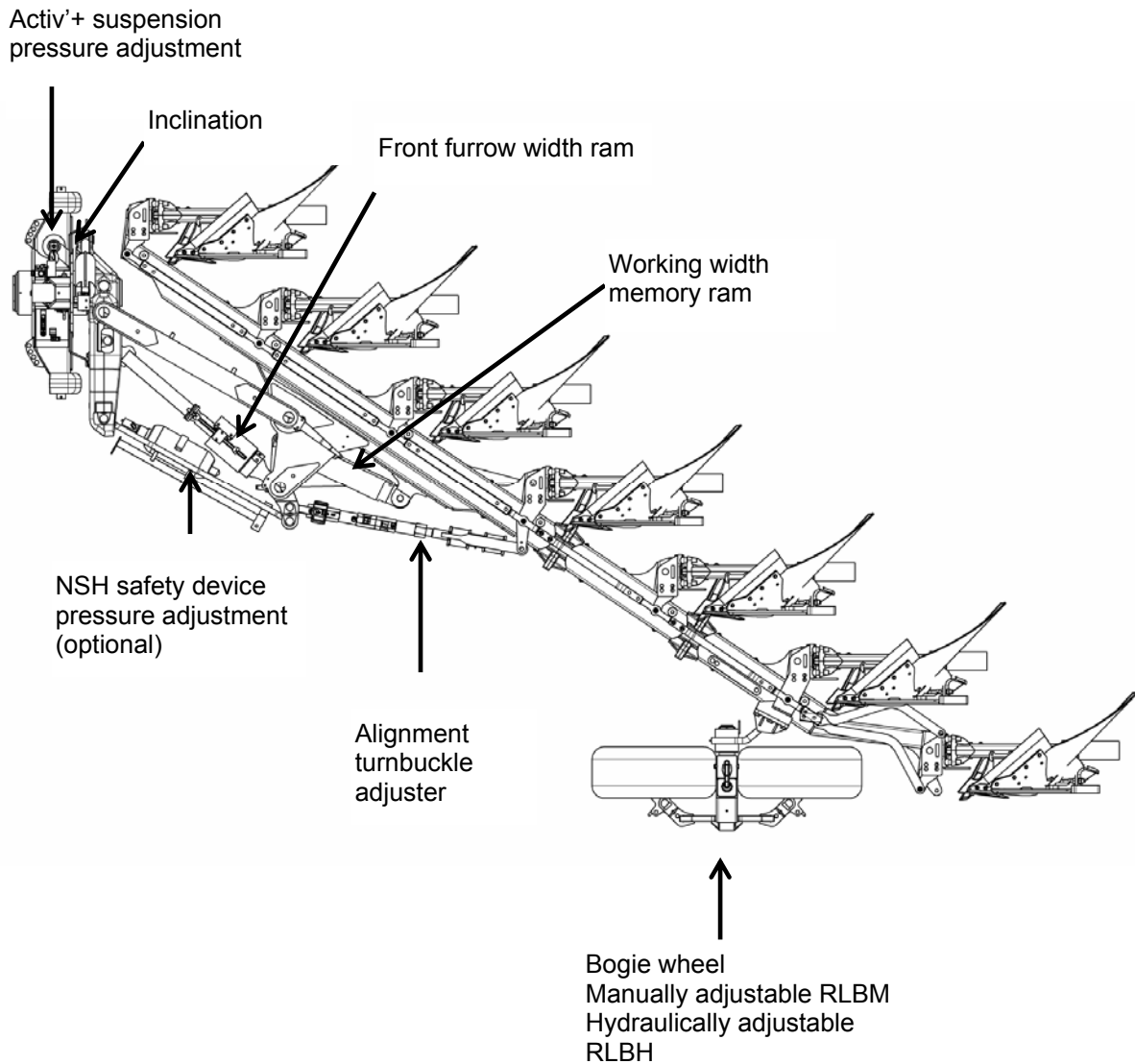

7.2. MACHINE WHEELS

7.2.1. Tyre inflation

Air pressure shall be checked every week. Do not let it drop below recommended pressure.

Tyre dimension	Recommended pressure	Minimum pressure	Maximum pressure	Maximum Speed
11.0 / 65 -12	3.0 bars	2.5 bars	3.5 bars	25 km/h
320 x 60 -12	2.5 bars	2.0 bars	3.0 bars	25 km/h

Follow tyre manufacturer recommendations (written on tyre side).



Tyre « above - inflation » = exploding risk.
Tyre « below - inflation » = rim come off risk.

7.2.2. Wheel studs

Check wheels general state and studs tightness every day.

Tread types tires may need more checking than conventional tires (more vibrations).

Always check for studs tightness before driving on public road. Tight them if necessary.

7.2.3. Height adjustment

The bogie double wheel height controls rear furrows ploughing depth.

- To increase ploughing depth, raise bogie wheel.
- To decrease ploughing depth, lower bogie wheel.

7.2.4. Anti-rotation axle

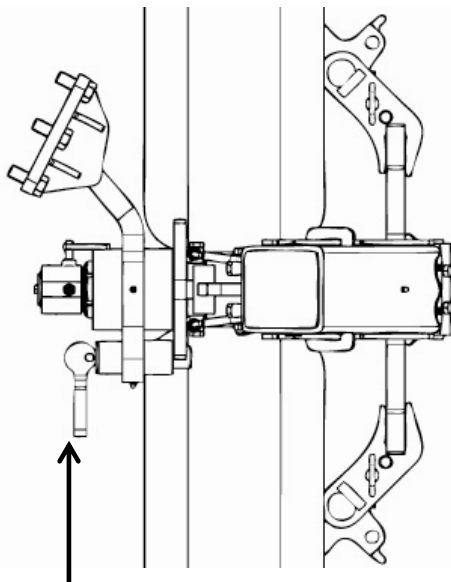

Anti-rotation axle
locked position

Anti-rotation axle limits wheel bracket rotation possibilities around its attaching pivot.

When it is locked (refer to picture), it prevents from wheel bracket rocking. Bogie can so control ploughing depth in irregular conditions : headlands, fields with heavy tracks, ...

Locking anti-rotation axle is an adaptation possibility to particular conditions.

Axle shall not be locked in most ploughing conditions.

Axle shall never be locked when wheel is in transport position.

7.3. PREPARING PLOUGH BOTTOMS

Grégoire-Besson plough bottoms are protected before leaving the factory to prevent rusting. Good field work can not be accomplished until this coating is removed : mouldboards do not shine, ground is stuck to the steel.

If necessary, use a solvent, such as paint remover to take the protective black paint off.



CAUTION : keep work area well ventilated when using solvent such as paint remover to remove protective paint. Wear eye and hand protection.

7.4. WORKING WIDTH ADJUSTMENT

7.4.1. Principle

RW9 is equipped with a mechanism for uninterrupted adjustment of working width according to conditions : type of soils, available horse power, type of ploughing desired (width / depth ratio, ...). Each bottom can plough from 12" to 20" wide (= 30 to 50 cm).

Mechanism is composed by a memory ram and an external double linkage. Maintenance and adding or removing extra furrows are easy.

Before each turn over, the machine is automatically closed to 12" wide. Once rolled over, memory ram brings it back to the previous ploughing width.

Refer to indicator on main frame to see bottom's individual working width.

7.4.2. Adjustment

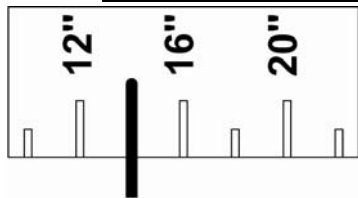

- Extend width memory ram to increase bottom's working width.
- Retract width memory ram to reduce bottom's working width.

7.5. ALIGNMENT ADJUSTMENT

7.5.1. Principle

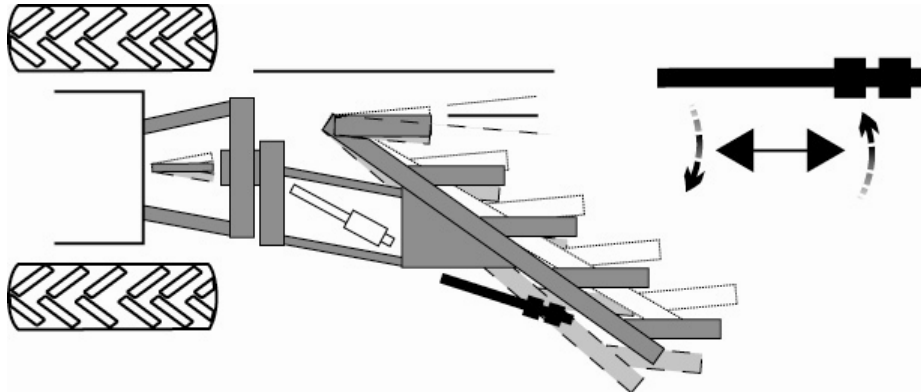

Alignment adjustment allows plough positioning behind tractor (rotation movement). Main frame shall pivot so that traction line of both bottoms and tractor are lined up. Then useless side draft is minimum and plough steering is easy.

7.5.2. Adjustment

Ploughing at desired depth and width, if alignment arm is properly set, top link shall be strictly lined up behind tractor. Therefore, final adjustment shall be done in the field. Refer to section 9.2.2.

However, check for alignment pre-adjustment before beginning field operations :

- Alignment arm axle to axle length for inter body distance **900 mm : 1 329 mm.**
- Alignment arm axle to axle length for inter body distance **1 000 mm : 1 666 mm.**

7.6. FRONT FURROW ADJUSTMENT

7.6.1. Principle

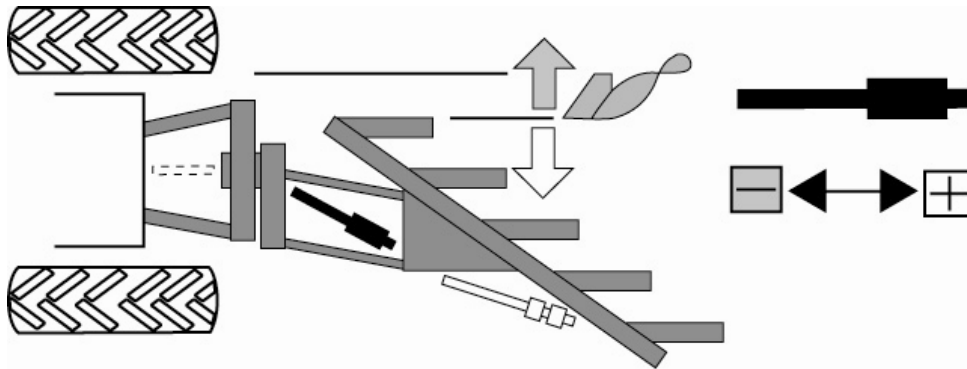

Front furrow adjustment allows width adaptation of first furrow according to the others (translation movement).
All bottoms working the same width will provide an even ploughing.

7.6.2. Adjustment

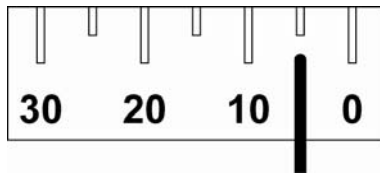

Starting at the second pass, when there is a furrow to fill, adjust front furrow so that it ploughs the same width as the others. Refer to section 9.3.4.

Note : in transport position, close front furrow to the minimum.

7.7. ACTIV'+ SUSPENSION ADJUSTMENT

Activ'+ hydraulic suspension of top link yoke hitch is composed by a ram (above yoke) and a gas accumulator (suspension). Refer to picture on section 3.5. In working conditions, when plough is lifted up, suspension absorbs pressures responsible for sway phenomenon. From the cab, operator shall see a **light movement of the top link yoke hitch** when he feels that tractor front end would raise, what should not occur.



IMPORTANT : this movement shall never exceed 5 mm.

- If **movement exceeds 5 mm**, **pressure** shall be **increased**.
- If there is no visible movement, pressure may be reduced.

Activ'+ suspension works only when plough is raised on working position.
It is inactive while ploughing since top link shall be free in the slot of the yoke.
It is inactive during road transport since top link yoke is disconnected.

Adjustment procedure

- Put plough in working position and lower it to the ground.
- Check for good connection of turn over hydraulic circuit, since Activ'+ suspension is a derivative of this circuit.
- Open suspension set screw situated on the front R.H. side of the headstock.
- To **increase pressure** in the system, **add oil** acting on turn over hydraulic control lever.
- To **decrease pressure** in the system, **remove oil** acting on turn over hydraulic control lever.
- **Always stay on the green zone of the gauge.**
- Once desired pressure is reached, close set screw. Activ'+ suspension circuit is now independent from turn over.
- Adjust Activ'+ suspension till optimum pressure is reached according to working conditions (number of bottoms, tractor weight, optional equipments, stuck ground, ...).

7.8. NON-STOP HYDRAULIC SAFETY DEVICE PRESSURE ADJUSTMENT

Plough is equipped with a 150 bars accumulator. For regular working conditions, pressure in non-stop hydraulic safety device shall be set between **160 and 200 bars**, which corresponds to the green zone on the gauge. **Always stay in this range.**

Adjustment procedure :

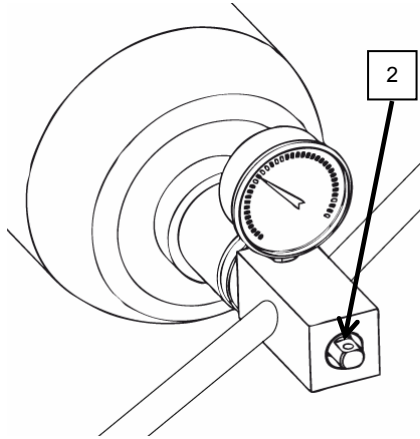

- Put plough in working position and lower it to the ground.
- Check for good connection of turn over hydraulic circuit, since non-stop hydraulic safety device is a derivative of this circuit.
- Open set screw (2) on accumulator situated on external fixed arm of parallelogram.
- To **increase Non-Stop Hydraulic safety device resistance**, increase hydraulic pressure in the system, **adding oil** acting on hydraulic control lever.
- To **decrease Non-Stop Hydraulic safety device resistance**, decrease hydraulic pressure in the system, **removing oil** acting on hydraulic control lever.
- Once desired pressure is reached, close set screw (2). Non-Stop Hydraulic safety device circuit is now independent from turnover circuit.

Clever way for an operator alone in the field :

- Open valve (2) and add more pressure than required in the circuit. Shut valve (2).
- In tractor's cab, put hydraulic control lever on "Float position".
- Slightly open valve (2) so that oil slowly goes back to tractor.
- Once desired pressure is reached, close valve (2). Then hydraulic hose (1) may be disconnected.

8. TRANSPORTING

Follow recommendations given in the safety section of this manual. They are not restrictive.

8.1. CHANGING TO TRANSPORT POSITION

Before driving on a public road with the machine, put it in transport position :



Carrier configuration



Transport lock pin



Top link yoke hitch in working position

Top link yoke hitch in transport position

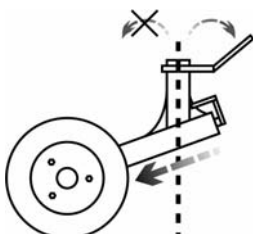

- **Put wheels in carrier configuration** : pivot each wheel $\frac{1}{4}$ turn around its mounting bracket and install lock pin. Anti-rotation axle must be removed.
- **Lower wheels to the maximum** : extend mechanical turnbuckle or hydraulic ram. This will improve stability during transport.
- **Install lock pin** : install transport safety lock pin (choose proper position on control box and use hydraulic control lever). Lubricate spring if lock pin is hard to move..
- **Retract front furrow width ram** : to lower plough's gravity centre (choose proper position on control box and use hydraulic control lever).
- **Turn plough over for $\frac{1}{4}$ turn** :
 - => before pivoting, it shall automatically close to 12" position,
 - => when turn over ram comes vertical, lock pin enters into frame hole which secures plough in transport position,
 - => use variable width ram to put machine in 14" width position. This will avoid contacts between elements and supports allowing rubber blocks to absorb shocks both ways.
- **Lower tractor hitch** : put plough on its carrier.
- **Release top link yoke** : move tractor hitch if pin is hard to remove. Then put pin in lower hole.
- **Adjust tractor hitch height** : wheel attaching pivot shall be vertical or slightly looking towards tractor. This will give good stability for on highway transport.
- **In the cab lock all control levers** : lock all control levers (hydraulic remotes, hitch, ...) to avoid any unforeseen movement, and potential accident.
- If tractor is equipped with a stabilizers locking system, install it to prevent any useless movement.
- **Install all lights, reflectors and signs required by current applicable law.**

8.2. CHANGING TO WORKING POSITION

To put machine in working position, follow here above described procedure in the opposite way.

8.3. DRIVING ON PUBLIC ROAD

Before driving on a public road :

- **Be sure all signs, reflectors and lights required by local current law are in place, clean and visible to traffic.**
- Make sure there are no interferences between tractor and machine.
- Adopt a gentle attitude towards other public road users.

On public road, comply with local applicable laws :

- Tractor required for road transport shall equal the size and the horse power rating of the tractor used to work in the field.
- Do not drive over 25 km/h (= 15 mph).
- Drive at a reasonable speed to maintain complete control of both tractor and machine.
- Reduce speed on corners and on rough grounds.
- Do not drive down a hill faster than it could be possible to drive it up.
- Do not apply the tractor brakes to attempt a sharp turn.
- Always check wheel studs tightness before driving on a public road. They may get loose because of vibrations.
- Respect authorized maximum size for transport load (width, weight, length). For over sized loads, comply with current law taking all necessary precautions (signs, lights, escort, authorizations, ...).
- Respect the maximum wheel axle load and the maximum total driving load. Make sure front axle carries at least 20% of tractor's tare. Use front end weights if necessary.

ATTENTION : driving on public roads, operator is responsible for both tractor and equipment. He has to comply with current applicable law (getting in conformity with it and following its evolutions).

9. FIELD ADJSUTMENT

Follow recommendations given in the safety section of this manual. They are not restrictive.

9.1. FIELD UTILIZATION

Put machine in working position (refer to previous section).

To reach a decent ploughing, operating speed shall be between 6 and 8 km / h (= 3.7 to 5 mph). Higher speed may lead to over wearing of wearing parts.

Always lift up machine before manoeuvring or turning on headlands.

Never attempt a sharp turn with the machine in the ground.

Reduce speed before manoeuvring or crossing obstacles (ditch, ridge, rocky spots, ...).

As long as possible, regularly change field opening side to avoid rolling ground always the same way. This could result in creating a ridge on one side of the field and a ditch on the other side.

Several up and down passes might be necessary before reaching an optimum ploughing, moreover with a new plough or at the beginning of a new season. During each pass, mouldboards get more polished, soil flow gets better and adjustments can be improved.

IMPORTANT : before beginning field utilization, entirely read this chapter to understand all adjustments, their order and procedure.

IMPORTANT : always do one adjustment at a time. Then it is easier to check its performance and to change it if necessary.

9.2. FIRST PASS

First pass differs from the others since tractor is not running in the furrow. This interferes with several adjustments : inclination and front furrow (width and depth).

9.2.1. Entering into the ground

Adjust working width using width adjustment ram hydraulic control lever. Refer to section 7.4. Drive slowly and lower the machine to have a smooth entering into the ground.

9.2.2. Alignment adjustment

This is the first adjustment to do ploughing with a fully mounted roll over plough. Stabilizers shall be free (2 to 5 cm loose). Refer to section 7.5.

- **Top link** shall be **strictly lined up** behind tractor.
- If **top link** looks **towards ploughed ground**, plough shall be lined up with tractor traction line **extending alignment arm**.
- If **top link** looks **towards non ploughed ground**, plough shall be lined up with tractor traction line **shortening alignment arm**.

9.2.3. Ploughing depth adjustment

Ploughing depth is controlled by :

- tractor hydraulic hitch height for the front end of the plough,
- gauge wheel height for the rear end of the plough.

9.2.3.1. Tractor hydraulic hitch height adjustment

Tractor hitch height is controlled from the cab. For the first pass first bottom cannot fill any furrow with ground. So set hitch height so that there is no formation of an excessive ridge.

9.2.3.2. Tractor draft control adjustment

To begin, set draft control on a minimum sensibility. Therefore front furrow depth will be easier to check and / or to adjust.

Later on, once plough is properly adjusted, draft control sensibility may be increased to improve tractor's adhesion.

Note : in bad conditions (wet fields, low horse power reserve, ...) it is impossible to work with minimum draft control. Hitch reactions to the load shall then be taken in account for average front furrow working depth estimation.

9.2.3.3. Gauge wheel height adjustment

Gauge wheel height may be approximately adjusted during first pass. Checking and / or readjustments will be done on the following passes.

- **To increase working depth, raise the wheel :**
 - ⇒ RLBM : shorten mechanical arm screwing turnbuckle
 - ⇒ RLBH : shorten hydraulic ram (use control box)
- **To decrease working depth, lower the wheel :**
 - ⇒ RLBM : extend mechanical arm unscrewing turnbuckle
 - ⇒ RLBH : extend hydraulic ram (use control box)

9.2.4. Side to side levelling = inclination adjustment

Final side to side levelling has to be done once tractor runs in the furrow.

For the first pass, set elements perpendicular with the ground (better penetration, easier pulling, ...). Use control box. Refer to section 9.3.3.

9.2.5. Front furrow width adjustment

Final front furrow width adjustment has to be done once tractor runs in the furrow.

For the first pass, set front furrow maximum offset from the tractor to plough as close as possible from the fence. Use control box. Refer to section 9.3.4.

9.3 SECOND PASS

Before any final adjustment, make sure mouldboards are scoured. Ground shall slide along steel and never stick. In heavy conditions, removing bolted points for the first working hours might help scouring mouldboards. Do not hesitate to contact an authorized Grégoire-Besson dealer in case of problem.

9.3.1. Alignment adjustment

Check for good alignment adjustment. Plough shall be properly lined up behind tractor, top link strict. Landsides shall slide along furrow wall, without excessive pressure.

9.3.2. Front to rear levelling

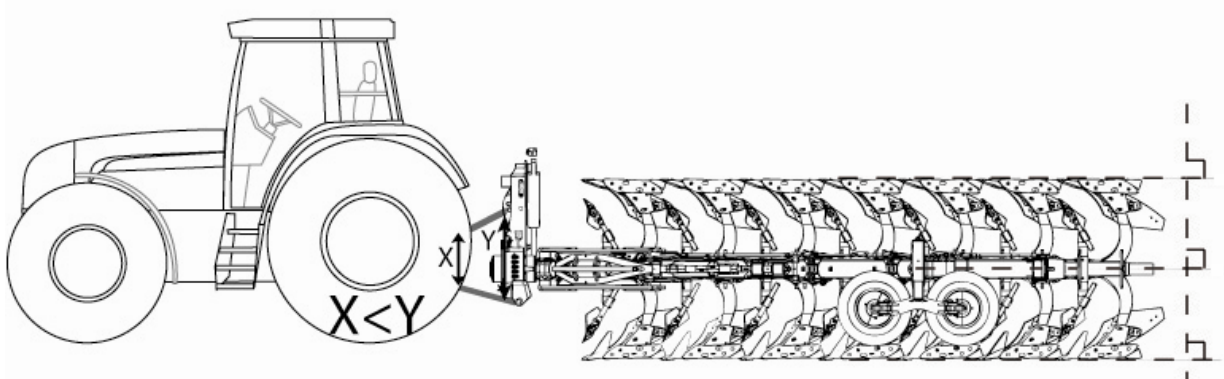

Once tractor runs in the furrow, plough has to be levelled from front to rear so that all bottoms work at the same depth (refer to picture).

Adjustment procedure

- For the desired ploughing depth, find the right balance between tractor hydraulic hitch height, gauge wheel height and top link length.
- **Top link position** : at work, top link shall always be positioned higher on machine side than on tractor side. This will allow a good weight transfer on front axle. Refer to picture, $X < Y$. Change top link fixing on tractor if necessary.
- **Top link length** : top link length shall be adjusted so that working at desired depth top link pin stays free to move in the slot.

9.3.3. Side to side levelling

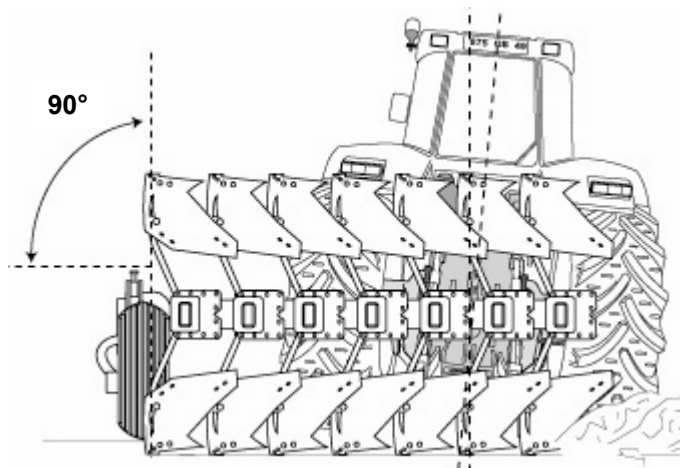

Once tractor runs in the furrow, plough shall be levelled from side to side. Bottoms shall run perpendicular with the ground. Refer to picture.

In specific conditions (sloping fields, heavy clay, ...) plough may be slightly tilted towards ploughed ground to increase mouldboard action on the soil.

Adjustment procedure :

- Put control box on “inclination” position. Corresponding hydraulic control lever commands turn over ram memory stopper.
- Act on hydraulic control lever to adjust side to side levelling “on the go”.
- When elements are strict up and down, machine pulls easier and ploughs evenly.
- Then control box can be used for another adjustment. After each turn over, memory ram will bring the plough back to the same position.

9.3.4. Front furrow width adjustment

If front furrow has been opened maximum for the first pass, close it for the second one. Final front furrow width adjustment shall be done once plough is correctly lined up both front to rear and side to side. For ploughs equipped with an hydraulic ram, this adjustment can be done “on the go”.

- **If front furrow leaves a ridge**, it ploughs too much ground. **Its width shall be reduced shortening front furrow arm.**
- **If front furrow leaves a hole**, it does not plough enough ground. **Its width shall be increased extending front furrow arm.**
- **Particular case :** => if front furrow ploughs excessive width, a hole may appear : mouldboard is so far from its theoretical position that it cannot bring ground far enough to fill the furrow,
=> working on sloping fields, it may be necessary to re-adjust front furrow width for each pass to leave a really levelled surface

Adjustment procedure

- Put control box on “front furrow width” position. Corresponding hydraulic control lever commands front furrow width ram.
- Act on control lever to adjust front furrow width “on the go”.
- When it is correctly set, it properly fills the furrow and there is no mark between two passes.
- Then control box can be used for another adjustment.

9.4. SAFETY DEVICE ADJUSTMENT

9.4.1. Shear bolt safety device type « BR9 »

In case of safety bolt shearing :

- Put plough in transport position, elements shall be horizontal to replace bolts without crushing risks.
- Pivot element to line up holes.
- Install new safety bolt. Special pointed screw allow chasing of all broken parts.



IMPORTANT : respect safety bolts specifications. Only use certified genuine Grégoire-Besson spare parts.

9.4.2. Non-Stop Hydraulic safety device type « Y » or « Z »

In case of excessive tripping

Ploughing is not even.

Pressure shall be increased in the circuit. Refer to section 7.8.



CAUTION : always stay in the green zone on the gauge. If maximum pressure is not high enough, contact an authorized Grégoire-Besson dealer. Larger diameter safety rams may be required.

In case of insufficient tripping

Bottoms hit rocks and bring them up. There is a risk for wearing and / or structure parts breaking. Useless pressures may damage the plough and affect its life time.

Pressure shall be reduced in the circuit. Refer to section 7.8.



CAUTION : never reduce too much the pressure in the circuit. Elements could fall down and cause severe injury or death by crushing.

9.5. BOTTOM PITCH ADJUSTMENT

$$Y = X - 15 \text{ mm}$$

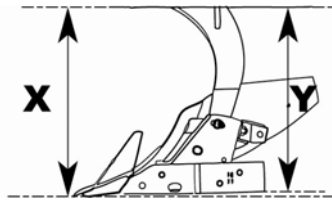

Grégoire-Besson bottom's pitch is adjustable. At the manufacture, it is set so that in working conditions front part (point) is 15 mm lower than rear part (end of landside). This adjustment is adapted to most ploughing conditions.

Before any modification of standard adjustments

Check wearing parts general state

Wearing parts worn out may lead to poor ploughing and / or poor penetration.

Think ahead for possible consequences

Pitch augmentation	better penetration (specially in dry grounds) plough harder to pull (more fuel consumption) excessive pressure on safety device stone climbing
Pitch reduction	ground escaping underneath mouldboard opposite effects poor penetration

FOR ALL CONDITIONS NEVER HAVE X < Y

Adjustment procedure

- Remove dirt from all bolts, nuts and threads.
- Remove wear plate (45) to reach bolt (41).
- Loose bolts (41) and (42), and both jam nuts (43) located on eye bolt (44).
- To increase the pitch, screw rear nut (43) on eye bolt (44).
- To decrease the pitch, unscrew front nut (43) on eye bolt (44).
- Once desired pitch is set, tight all bolts and install back wear plate (45).
- **All bottoms on both sides shall have the same pitch for the plough to work evenly.**

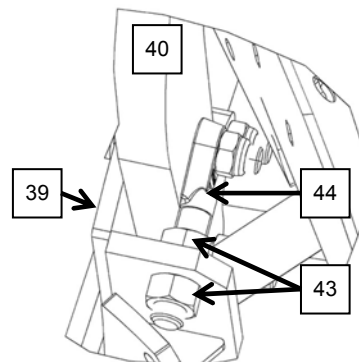
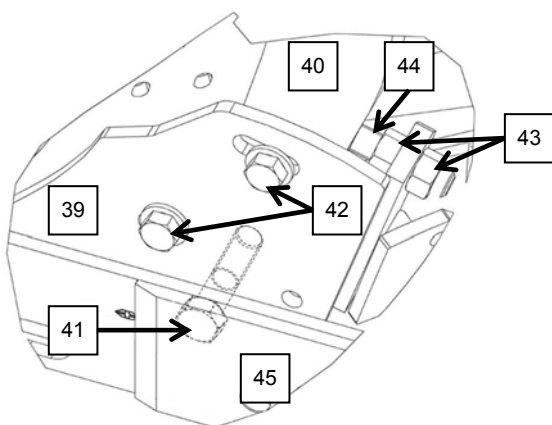

9.6. SKIMMER ADJUSTMENT

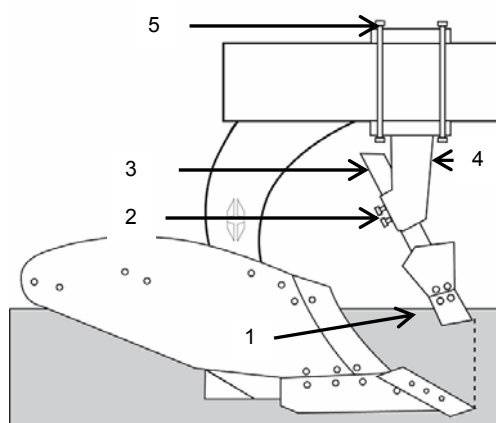

Skimmers provide good trash coverage. They are protected by a shear bolt safety device. Grégoire-Besson skimmers have been specially designed to be adjustable by an operator alone in the field.

9.6.1. Shear bolt safety device

Each skimmer is protected by a shear bolt. When hitting an obstacle, this bolt would break for skimmer to raise up.

In case of bolt shearing

- Remove all broken parts
- Install a new safety bolt

=> standard : screw ref. VI 29 08, H M12x45, grade 8.8 + nut ref. VJ 322.

=> reinforced : screw ref. VI 29 09, H M12x45, grade 10.9 + nut ref. VJ 322.

9.6.2. Skimmer height adjustment

In general, skimmer share (1) should work the ground for half of its height to be efficient (refer to picture).

Guideline for adjustment

- Skimmer height adjustment is linked to ploughing depth, so it shall be checked after each ploughing depth changing.
- If skimmer is set too high : there is a plugging risk behind it, if there is still too much residue on the surface.
- If skimmer is set too low : there is a plugging risk ahead it, if there is too much material coming in. In this case, plough is hard to pull.

=> Both situations lead to poor trash coverage.

Adjustment procedure

- Loose the two pointed screws (2).
- Move skimmer arm (3) through its mounting bracket (4) to reach the desired height.
- Tight both pointed screws (2) inside marks of arm (3).
- In a first time, adjust 1 or 2 skimmers and make a try. If it is better, then adjust all other skimmers. If not, go back and try another adjustment.
- **All skimmers shall be set the same on both sides so that plough works evenly.**
- Special long arms (3) for shallow ploughing are available. Contact an authorized Grégoire-Besson dealer.

9.6.3. Skimmer front to rear adjustment

In general, skimmers are pre-adjusted at the manufacture for its share to be lined up with bottom's point (refer to picture on previous page).

Guideline for adjustment

- If skimmer is ahead from the point, crop residue is ploughed down in the furrow.
- If skimmer is behind the point, crop residue is ploughed higher in the furrow.
- In heavy trash conditions, it might be necessary to set skimmer behind the point.

Adjustment procedure

- Loose the four carriage bolts (5).
- Move skimmer mounting bracket (4) to the desired position.
- Tight all four carriage bolts (5).
- In a first time, adjust 1 or 2 skimmers and make a try. If it is better, then adjust all other skimmers. If not, go back and try another adjustment.
- **All skimmers shall be set the same on both sides so that plough works evenly.**

10. MAINTENANCE

Follow recommendations given in the safety section of this manual. They are not restrictive.

10.1. GENERAL INSTRUCTIONS



Operator and user are responsible for good machine maintenance.



Inspect machine before and after each use. Repairs and service have to be done immediately so that they are not forgotten. Always leave the machine in a good state.

Cleaning the machine facilitates inspection. Check general state of machine, weldings, wheels studs, tyres, ...

Be careful with hydraulic lines : frictions may lead to excessive wearing and lines may leak. Never search a leak with your hands. Immediately replace any defective component. Spare components shall have the same characteristics.

Parts working in the ground may be sharpened and cause severe injury. Take particular care and use heavy leather gloves to remove them.

Never attempt any intervention on the machine while tractor engine is running.

Always properly secure all components before starting any maintenance operation underneath the machine.

Before using the machine for the first time, check all bolts tightness. Verify after 50 working hours and then at the beginning of each season. Pay special daily attention on :

- wheel studs tightness
- wearing parts bolts and nuts tightness in rocky or dry conditions (lots of vibrations).

Wrong waste management is a danger for environment : collect waste oil, paint removers, accumulators, worn tyres ... Bring them back to a distributor or to an authorized collector. Do not let them in the nature.

10.2. LUBRICATION

A good lubrication of all moving parts will both allow the machine to work fine and insure its long-lasting.

Grease fittings are installed on all pivot points. Grease both lubricates moving parts and chases away abrasive dust or water that could come into pivot points.

Use quality grease, type Unil – Opal MS02 or equivalent.

Always wipe grease fittings with a clean rag before introducing grease. Do not hesitate to change any worn or broken grease fitting. Check for good grease course.

Remove all grease accumulation around grease fittings or moving parts.

Refer to grease fittings placement on the following drawing. Grease every 50 working hours on a regular use. Hard or intense conditions would require more.

The best is to grease regularly with regular quantity. Do not over grease.

GREASE FITTINGS ON ELEMENTS

- 1 on element attaching pivot
- 1 on each side on vari-width link rod
- Safety B 0 grease fitting
- Safety Y or Z 1 grease fitting on each element rod pivot pin

Safety Y or Z : for good greasing on pivot point, put machine in transport position and release pressure on hydraulic circuit

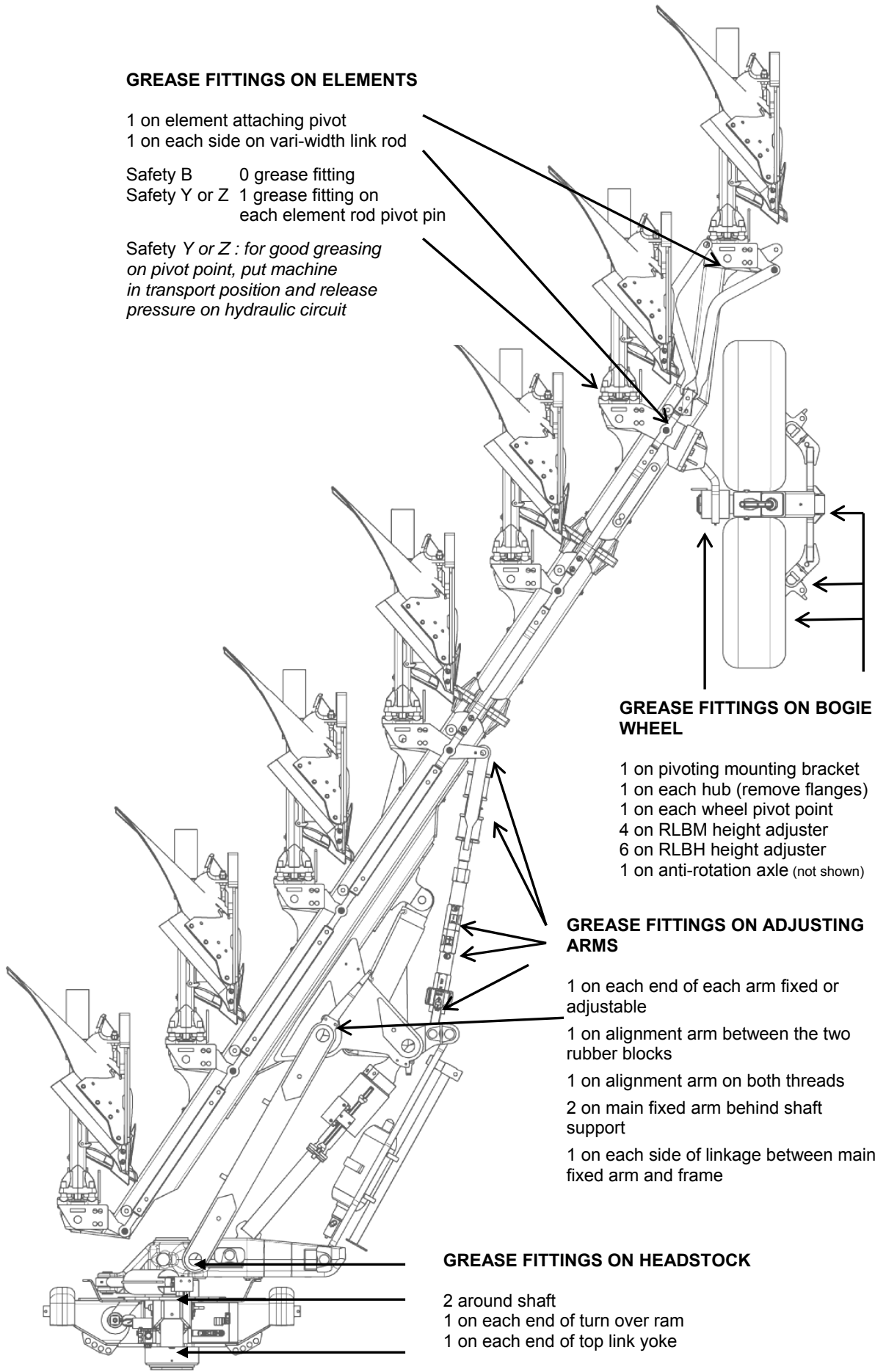

GREASE FITTINGS ON BOGIE WHEEL

- 1 on pivoting mounting bracket
- 1 on each hub (remove flanges)
- 1 on each wheel pivot point
- 4 on RLBH height adjuster
- 6 on RLBH height adjuster
- 1 on anti-rotation axle (not shown)

GREASE FITTINGS ON ADJUSTING ARMS

- 1 on each end of each arm fixed or adjustable
- 1 on alignment arm between the two rubber blocks
- 1 on alignment arm on both threads
- 2 on main fixed arm behind shaft support
- 1 on each side of linkage between main fixed arm and frame

GREASE FITTINGS ON HEADSTOCK

- 2 around shaft
- 1 on each end of turn over ram
- 1 on each end of top link yoke

10.3. SPARE PARTS

Genuine Grégoire-Besson parts have been specially designed and developed. Only the use of these parts will ensure proper fit, longevity and field quality work of the machine.



Using any other spare part than certified from Grégoire-Besson will void warranty.

Changing wearing parts too late may be cause of poor quality work (penetration troubles, poor mixing ...) and may damage structure parts°.

10.4. WORKING BOTTOMS MAINTENANCE

Protect all parts working into the ground (mouldboards, shares, shins, disc blades) from rust whenever the plough is not used by applying a light coating of oil or grease.

While working in sticky grounds, even for a short stop, cover mouldboard with a coat of light oil (WD 40 in spray).

For longer stops, heavier oil will stay longer on mouldboards. Dry spray type graphite also, this one being removed faster.

10.5. STORAGE SAFETY

- Before detaching the machine for storage, make sure ground is clean, flat and firm enough.
- Use parking stand and all other locking devices to prevent from any unforeseen movement during detachment or later on.
- Block machine wheels to avoid any unforeseen movement.
- During storage, wheels shall not carry any weight.
- NEVER detach machine in raised position.
- Remove pressure from hydraulic circuit (engine shut off, shake hydraulic control lever in the cab).
- Store machine away from human activity.
- Store machine in a dry and dust free area (shed). Protect ram rods that cannot be retracted from rust using grease or oil.

CAUTION : never let children play around farm equipment.

11. QUICKLY STARTING - R W 9

Take all precautionary measures. Respect safety recommendations.

PREPARING THE TRACTOR

- 1. Check tyre pressure**
It should be the same on both sides on each axle.
- 2. Adjust tractor hitch levelling**
Set lift links length for tractor hitch to be perfectly level with the ground.
Use a strict bar to verify lift links length alignment with the ground and / or rear axle.
Arms shall be long enough so that working at desired depth there is still 30 mm chrome visible on lift ram.
- 3. Adjust lift links lateral sway**
Transport position minimal sway (≤ 1 cm)
Working position lateral sway 2 to 5 cm
- 4. Check top link**
Connexion between top link and machine must be done through a tie rod and not through an automatic hook.

HITCHING

- 5. Attach lower links**
- 6. Attach top link**
- 7. Make sure there are no interferences between machine and tractor from raised position to working position**
Machine shall never come in contact with tractor.
There should be no contact between tractor lift links and machine yoke hitch from raised position to working position.
- 8. Connect hydraulic lines and control box**
- 9. Transport / working positions**
Transport position wheels in carrier configuration, elements in horizontal position, safety lock pin installed, top link yoke free, front furrow width ram retracted, plough in 14" width position, wheel mounting bracket maximum extended, wheel attaching pivot vertical or slightly looking towards tractor, anti-rotation axle removed.
Working position wheels in bogie configuration, frame safety lock pin unlocked, top link yoke attached, ACTIV+ suspension MAXIMUM movement = 5 mm.

FIRST PASS

- 10. Adjustment alignment**
Top link shall be lined up with tractor.
- 11. Adjust + / - working depth with bogie wheel height**
- 12. Adjust + / - working width with according to conditions**

SECOND PASS

- 13. Adjustment alignment**
- 14. Front to rear levelling**
Top link shall be positioned higher on machine side than on tractor side and shall be free in the slot while ploughing (adjust length).
Adjust both tractor hydraulic lift height and bogie wheel height so that plough works in horizontal position at desired depth.
Check draft control adjustment and visible chrome visible on lift ram (30 mm minimum).
- 15. Side to side levelling**
Elements shall be perpendicular with the ground.
- 16. Adjust front furrow width of cut**
Once plough is levelled, adjust front furrow width of cut so that ploughing is even, without formation of ridge or hole between two passes.

MAINTENANCE

- 17. Follow recommendations given in this manual according to lubrication and maintenance of the machine**

GRÉGOIRE  **BESSON**

**49230 MONTFAUCON-MONTIGNÉ-SUR-MOINE
FRANCE**

**TÉL. (+33) (0)2 41 64 72 67
FAX (+33) (0)2 41 64 67 73**

GRÉGOIRE-BESSON UK

Bourne Road, Carlby - STAMFORD Lincs PE9 4 NG – ENGLAND
phone (44) 01 778 590 223 - Fax (44) 01 778 590 645

GRÉGOIRE-BESSON CANADA INC

4480, Rue Martineau - ST-HYACINTHE (P. Québec) - CANADA J2R 1V1
TÉL. (1) 450 799 56 15 - FAX (1) 450 799 56 29

GRÉGOIRE-BESSON POLSKA

Ruda 12 - PL - 64610 ROGOZNO – TÉL / FAX (48) (67) 261 97 79

ООО «ГРЕГУАР-БЕССОН ВОСТОК»

Россия 308006 г. Белгород,
ул. Корочанская, 132а
Тел/факс: +7(4722) 58 70 36, 58 70 35
E-mail: info@gbvostok.ru
www.gregoire-besson.com

法国格力格尔 - 贝松公司北京代表处
北京市朝阳区延静里中街3号长信大厦220室
邮编：100025

WEB : www.gregoire-besson.fr **E.MAIL** : Contactfr@gregoirebesson.fr