

GRÉGOIRE  **BESSON**

CULTIS & CULTIS R

Fully mounted light cultivators

Fixed or 3 parts vertical foldable

OPERATOR'S MANUAL MAINTENANCE INSTRUCTIONS



GRÉGOIRE-BESSON S.A.

Rue Victor Grégoire
49 230 MONTFAUCON – MONTIGNÉ
France

Phone : 33 (0) 2 41 64 72 67
Fax : 33 (0) 2 41 64 67 73

Web : www.gregoire-besson.com
Email : Contactfr@gregoirebesson.com

Original version
November 2009

TABLE OF CONTENTS

1. INTRODUCTION	4
PRODUCT IDENTIFICATION	4
2. SAFETY INSTRUCTIONS	5
2.1. SAFETY STICKERS	5
2.2. SAFETY WHILE ATTACHING AND DETACHING	7
2.3. SAFETY WHILE CONNECTING HYDRAULIC LINES	7
2.4. SAFETY WHILE OPERATING MACHINE	7
2.5. SAFETY FOR MAINTENANCE	8
2.6. SAFETY FOR ON HIGHWAY TRANSPORT	8
3. MACHINE DESCRIPTION	9
3.1. IDENTIFICATION VIEWS	9
3.2. TECHNICAL SPECIFICATIONS	10
3.3. DIMENSIONS AND WEIGHTS	10
3.4. LIGHTS AND SIGNS KITS	10
3.5. TINE SQUARE 30 mm	11
3.6. ACCESSORIES	11
<u>3.6.1. Accessories availability</u>	11
3.6.1.1. Rear roller	11
3.6.1.2. Gauge wheels	11
3.6.2. Combination possibilities	11
4. PREPARING THE TRACTOR	12
4.1. REQUIRED HORSE POWER	12
4.2. TRACTOR WHEELS	12
<u>4.2.1. Tractor tyre</u>	12
<u>4.2.2. Distance between tractor tyres</u>	12
4.3. POSITIONING STABILIZERS	13
4.4. LIFT LINKS LENGTH	13
4.5. FRONT END WEIGHTING	13
4.6. TOP LINK	14
5. ATTACHING AND DETACHING	15
5.1. ATTACHING MACHINE TO TRACTOR	15
<u>5.1.1. Tractor equipped with tie rods lower links</u>	15
<u>5.1.2. Tractor equipped with automatic hooks lower links</u>	15
<u>5.1.3. Hitching top link</u>	16
5.2. DETACHING THE MACHINE	16
6. HYDRAULIC CONNEXIONS	18
6.1. REQUIRED HYDRAULIC REMOTES	18
6.2. HYDRAULIC CONNECTIONS	18
7. PREPARING THE MACHINE	19
7.1. ADJUSTING POINTS LOCALIZATION	19
<u>7.1.1. Configuration Cultis + rear roller</u>	19
<u>7.1.2. Configuration Cultis + gauge wheels</u>	19
7.2. ADJUSTING REAR ROLLER	20
7.3. ADJUSTING GAUGE WHEELS	20

8. TRANSPORTING	21
8.1. CHANGING TO TRANSPORT POSITION	21
8.2. CHANGING TO WORKING POSITION	22
8.3. DRIVING ON PUBLIC ROAD	22
9. FIELD ADJSUTMENT	23
9.1. FIELD UTILIZATION	23
9.2. CONFIGURATION CULTIS + ROLLER	24
<u>9.2.1. Depth control and front to rear levelling</u>	24
<u>9.2.2. Side to side levelling</u>	24
<u>9.2.3. If ground is not levelled</u>	24
9.3. CONFIGURATION CULTIS + GAUGE WHEELS	25
<u>9.3.1. Depth control and front to rear levelling</u>	25
<u>9.3.2. Side to side levelling</u>	25
10. MAINTENANCE	27
10.1. GENERAL INSTRUCTIONS	27
10.2. LUBRICATION	27
10.3. SPARE PARTS	28
10.4. STORAGE SAFETY	28
ANNEX 1 – WEIGHT DISTRICTION	29
QUICKLY STARTING - CULTIS & CULTIS R	32

Any use and / or reproduction of all or part of this manual without written authorization from Grégoire-Besson is strictly prohibited.

NOTES

1. INTRODUCTION



READ CAREFULLY THIS MANUAL



To properly start, operate and service your equipment, follow all instructions given in this manual.

THIS MANUAL SHOULD BE CONSIDERED AS A PART OF THE EQUIPMENT AND SHOULD FOLLOW IT WHEN YOU SELL IT.

LEFT HAND SIDE AND RIGHT HAND SIDE, FRONT AND REAR are determined looking from equipment towards tractor when in work.

ALL INFORMATIONS, PICTURE, SPECIFICATIONS in this manual are based on the newer information available at the time of publication. Pictures and drawings might not represent standard equipment and show optional attachments.

Manufacturer reserves right to make any changes at all time **without any obligation to notice or to modify any delivered or already sold machine.**

If the machine has been modified in any way from the original design without written agreement from Grégoire-Besson, the manufacturer does not accept any liability for injury or warranty. Warranty would become void.



This symbol is used in the following manual to **catch your attention on warnings concerning your safety.**

So please when you see it in this manual or on the equipment, **strictly follow given information.**

Grégoire-Besson equipments are exclusively designed to be used by professionals for regular farm tillage in farmed fields. Manufacturer shall not be responsible for damage or injury resulting from any other use.

Grégoire Besson equipments are designed according to applicable european regulation : EEC directive 2006/42. The CE logo is on identification plate. Provided Declaration of Conformity testifies that machine complies with essential health and safety requirements for users.

PRODUCT IDENTIFICATION

Please record here purchasing date, model and serial number of your equipment (refer to identification plate on hitch). Always refer to these information to get prompt and good service. Fill and send back machine registration form for warranty.

Purchasing date :

Model :

Serial number :

Salesman's phone :

2. SAFETY INSTRUCTIONS

2.1. SAFETY STICKERS



Reference : UI 1980

READ OPERATOR'S MANUAL

Read operator 's manual and safety instructions before starting the use of your equipment and follow them while using.



Reference : UI 1978

STAY IN A SAFE POSITION

Do not climb on the machine. Do not stand between machine and tractor.



Reference : UI 127

MOVE AWAY FROM THE MACHINE

Danger in the working area, stay clear from the machine.



Reference : UI 126

UNFOLDING AREA

Stay clear of equipment when folding or unfolding.



Reference : UI 131

SECURE THE MACHINE BEFORE ACTION

Always install all lockup devices to secure machine before any intervention on it.



Reference : UI 1979

MOVING PARTS

Always stay far away from parts in movement.



Reference : UI 128

HYDRAULIC LEAK AND MAINTENANCE

Caution, high pressure fluids can cause injury. Follow safe practices.



Reference : UI 1981

MACHINE UNFOLDING

Never stand under machine lateral sections. Always store machine unfolded.

Positioning safety stickers on the machine

When cleaning the machine, do not damage stickers.
Replace any damaged or missing sticker.

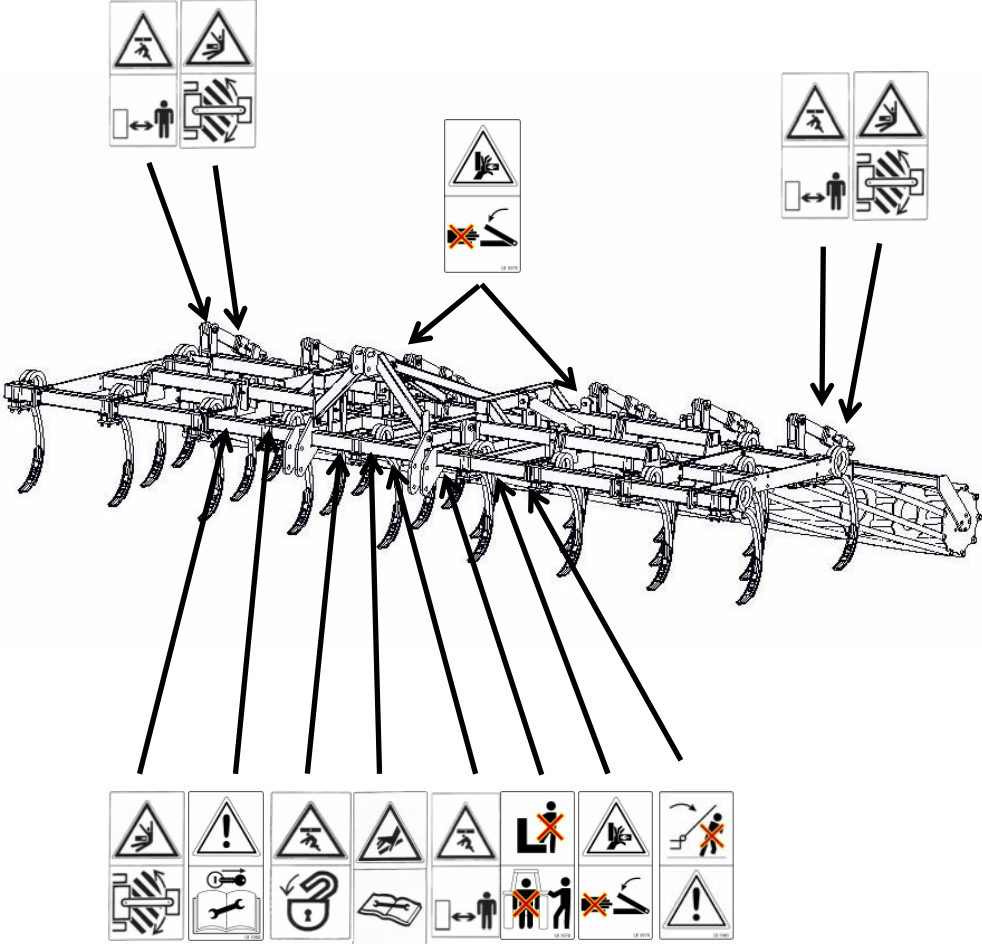

2.2. SAFETY WHILE ATTACHING AND DETACHING



- Do not let **anyone to stand between the machine and the tractor** when you back up to hitch.
- Before leaving the tractor to hitch or unhitch, set tractor parking brakes.
- Never attempt to attach the machine if pins, tractor hitching balls, tractor drawbar, or machine linkage are worn, cracked or not compatible.
- Completely lower the machine to the ground before unhitching. Make sure it is on a level and firm surface.
- Remove pressure from hydraulic lines before disconnecting them.
- Before leaving the machine for storage, make sure it is in a safe place and that there is no risk to damage whether anything or anyone.

2.3. SAFETY WHILE CONNECTING HYDRAULIC LINES



- Hydraulic circuit might be highly pressurised.
- **Never use your hands to locate a hydraulic leak.** Hydraulic fluids escaping under pressure have sufficient force to penetrate the skin, causing severe injury. In case of any injury, **see a doctor immediately.**
- For equipments loaded with several hydraulic connectors, **make logical and appropriated connections.**
- Before connecting hydraulic circuit, **make sure that there is no pressure on both sides (tractor and machine).**
- Regularly check hydraulic lines and connections. **Replace any damaged or leaking component** by an original part with the same specifications.
- Before any intervention on hydraulic circuit, **lower machine to the ground and release pressure moving control lever in the tractor's cab.**

2.4. SAFETY WHILE OPERATING MACHINE

- **Never attempt** any intervention on the machine while it is in motion.
- Do **not** allow anyone to **stand close to pivot points** : bottoms safety device (shearing bolt or non-stop), all pivoting linkage.
- Wear close **fitting clothing** and **appropriate safety devices** for the job you have to do (heavy leather gloves, safety shoes, earplugs, ...).
- Do not allow anyone to stand close to the machine.
- Do not attempt to do any adjustment if you have not perfectly understood its procedure.
- Always use tools or equipments appropriate to the job you are doing. All Grégoire-Besson equipments are metric standards.
- Learn how to operate your machine and how to use its controls. Do not let anyone operate without instruction.
- Do not extend turnbuckle adjusters too much to avoid any threads damaging or intempesive pulling out.
- Only one person (the operator) should be in the tractor's cab when it is in operation. **No one on the machine while working or travelling on the road.**
- When earring or feeling unusual vibrations, stop the machine. Find the problem and solve it before starting operating again.



If your machine is equipped with a hydraulic folding mechanism, **always use it from tractor's cab**, once you are sure that folding area is free from spectators or obstacles.

2.5. SAFETY FOR MAINTENANCE



- Maintenance area shall be **clean, dry, with enough light and ventilation**.
- For any intervention on the machine in raised position, **always securely support all components** before starting maintenance.
- **Maintenance operations on elements under pressure or under tension** (resorts, accumulators, ...) require specific procedure and equipments. **Only qualified persons shall perform them in appropriate conditions.**
- After servicing remove all tools, components and parts you used.
- Regularly **check tightness of wheel studs, wearing parts bolts, and all other bolts and nuts.**
- **Always use genuine parts corresponding to manufacturer's technical specification requirements.**

2.6. SAFETY FOR ON HIGHWAY TRANSPORT



FOR YOUR OWN SAFETY AND THE ONE OF THE OTHER, RESPECT THE FOLLOWING RULES :

- All Grégoire-Besson equipments shall be used **complying with area's current rules and laws** concerning **safety instructions, accident prevention and provision of Highway Code**.
- Before road transport, always **check for wheels studs** and wheels mounting brackets carriage bolts **tightness** ; **check tyres general state and pressure** : do not drive with low pressure, cuts or damaged tyres or rims.
- **Use all devices required by your area's current laws** (lights, reflectors, signs, ...). They might be removed during field operation to prevent from any damage. It is the operator's responsibility to comply with current law and to follow its evolutions.
- Regularly check hitching pins, change them if necessary. Tractor's ball joint may also wear, do not hesitate to replace them with new ones having at least Waltersheid fabrication quality.
- Drive **at reasonable speed** complying with local laws **to always keep control** of tractor and equipment. Pay special attention on irregular or rough roads. **Do not attempt to drive down a hill faster than it could be possible to drive it up.**
- Tractor used for road transport shall have the same power rating and weight as the one used for field operations.
- **Never attempt any manoeuvre if area is not free from spectators.**
- If your machine is equipped with a **folding mechanism** (manual or hydraulic), **use it making sure folding area is free from spectators** and obstacles.
- Follow all **safe driving practices** when travelling, moreover **on corners, rough or narrow roads**.
- When **leaving tractor** even for a short period, **shut off engine, remove ignition key and set parking brakes**.
- Forbid anyone to stand between tractor and machine or on the machine travelling on the road.

3. MACHINE DESCRIPTION

3.1. IDENTIFICATION VIEWS

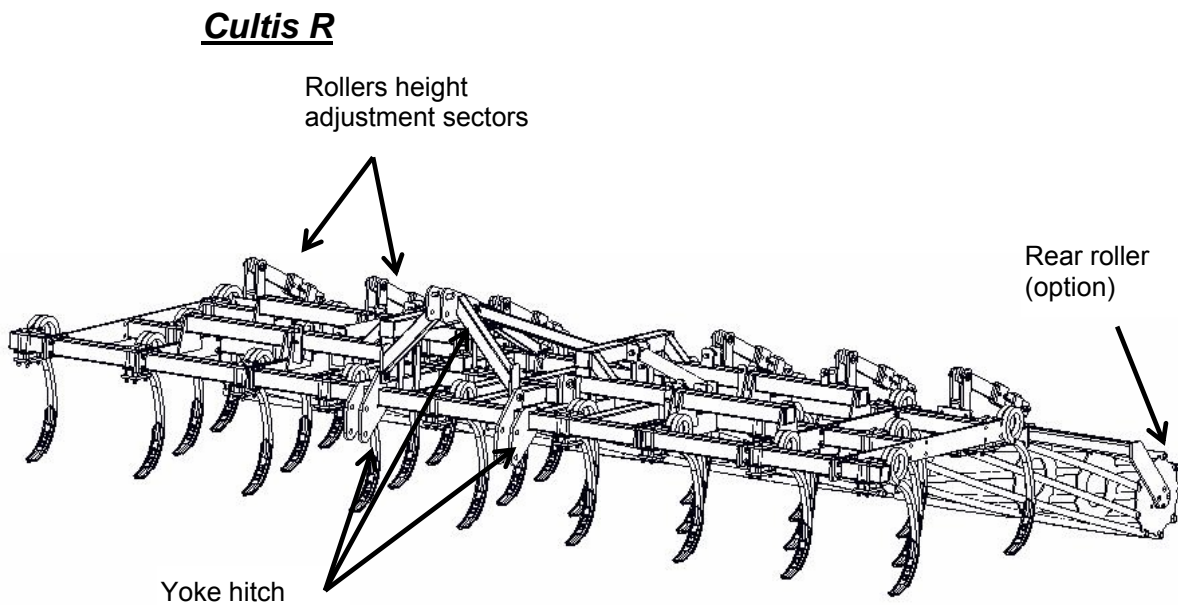
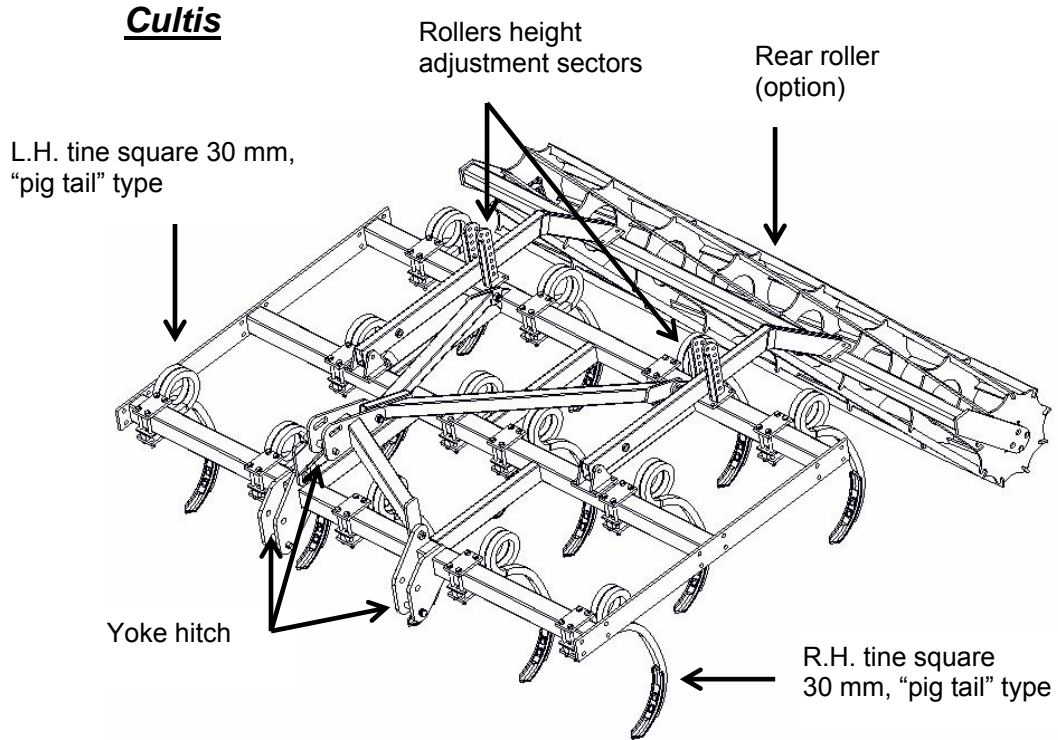

3.2. TECHNICAL SPECIFICATIONS

Specification	Équipement
Hitch	<ul style="list-style-type: none"> • 3 points hitch in yoke, cat. II
Frame	<ul style="list-style-type: none"> • Three beams 80 x 80 mm • Under frame clearance 680 mm • Beam to beam distance 700 mm • Cultis = fixed frame • Cultis R = foldable 3 parts frame, transport width 3.00 m
Working width	<ul style="list-style-type: none"> • From 2.60 m (11 tines) to 6.10 m (27 tines)
Depth control	<ul style="list-style-type: none"> • By rear roller Ø 500 mm or Ø 600 mm • By gauge wheels
Tines	<ul style="list-style-type: none"> • Tine square 30 mm, « pig tail » type • Reversible bolted point 40 x 16 mm • Wing shares (option)

A large choice of options is available to improve machine's job. Grégoire-Besson authorized dealers know area and working conditions. They may give information according to technical choices and latest equipments evolutions. Grégoire-Besson is also represented on farm equipment shows.

3.3. DIMENSIONS AND WEIGHTS

Number of tines	Working width	Transport width (mach. alone)	Longueur hors tout		Indicative weight (machine alone)
			Alone	With roller	
11 (fixed)	2.60 m	2.60 m	2.20 m	3.20 m	510 kg
13 (fixed)	3.00 m	3.00 m	2.20 m	3.20 m	560 kg
15 (fixed)	3.40 m	3.40 m	2.20 m	3.20 m	700 kg
17 (fixed)	3.80 m	3.80 m	2.20 m	3.20 m	760 kg
17 (fold.)	4.10 m	3.00 m	2.20 m	3.20 m	1 050 kg
19 (fold.)	4.50 m	3.00 m	2.20 m	3.20 m	1 110 kg
21 (fold.)	4.90 m	3.00 m	2.20 m	3.20 m	1 250 kg
23 (fold.)	5.30 m	3.00 m	2.20 m	3.20 m	1 310 kg
25 (fold.)	5.70 m	3.00 m	2.20 m	3.20 m	1 450 kg
27 (fold.)	6.10 m	3.00 m	2.20 m	3.20 m	1 510 kg

Dimensions and weights are indicative and subject to variations according to equipments and options.

Note : after use, ground or residue accumulations may increase machine's weight.

3.4. LIGHT AND SIGNS KITS



Light and signs kits are available for all Grégoire-Besson equipments. Contact an authorized dealer.

Note : it is the operator's responsibility to comply with local current applicable law before any transport on public road.

3.5. TINE SQUARE 30 mm



Machine is equipped with « pig tail » tines square 30 mm (refer to picture). These tines have reversible bolted points.



As an option, wing shares may be added (refer to picture). They are recommended for shallow tillage (stubble cultivation, ...).

3.6. ACCESSORIES

3.6.1. Accessories availability

3.6.1.1. Rear roller



Machine may be equipped with a rear crumbler roller flat steel profile, Ø 500 mm or Ø 600 mm (round tube or square bar profile as an option). Roller use allows depth control and improves machine stability in the field. Indicative weight : 140 kg / linear meter.

3.6.1.2. Gauge wheels

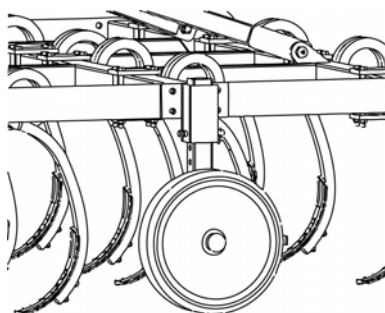

Machine may be equipped with a pair of gauge wheels. Gauge wheels use allows depth control and improves machine stability in the field.

Gauge wheels may have :

- pneumatic tyre, type 200 x 14.5, Ø 610 mm, width 210 mm, maximal pressure : 5 bars, follow manufacturer's recommendations
- steel wheels Ø 500 mm

Indicative weight : 130 kg / pair

3.6.2. Combination possibilities

Several combinations are possible for Cultis range :

- Cultis + rear roller
- Cultis + gauge wheels

4. PREPARING THE TRACTOR

Follow recommendations given in the safety section of this manual. They are not restrictive.

4.1. REQUIRED HORSE POWER

Tractor requirements may vary according to ground and working conditions (type of soil, type of tractor, type of tyres, ...). Following data are only indicative. Ask an authorized Grégoire-Besson dealer for any further information.

Working width	Indicative required HP
2.60 m	80 HP
3.00 m	90 HP
3.40 m	100 HP
3.80 m	110 HP
4.10 m	120 HP
4.50 m	130 HP
4.90 m	145 HP
5.30 m	160 HP
5.70 m	175 HP
6.10 m	190 HP

4.2. TRACTOR WHEELS

4.2.1. Tractor tyres

Check tractor tyres general state and pressure. Pressure should be the same on both sides of the tractor for a nice drivability in the field and on the road.



IMPORTANT : inflate tyres following manufacturer's recommendations.

4.2.2. Distance between tractor tyres

Generally, using a large tillage equipment, the wider is the distance between tyres, the better is the drivability.

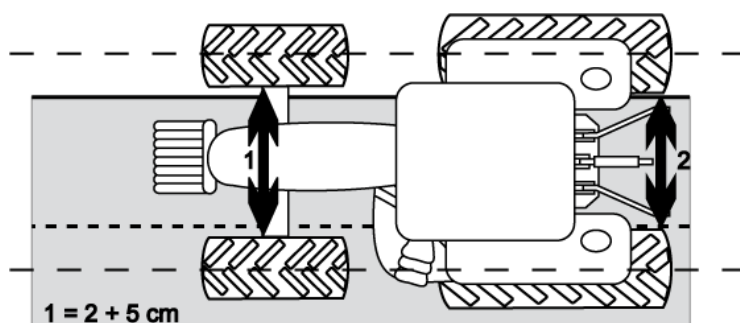

To be able to steer the tractor, the middle of the front axle shall be lined up with the middle of the rear axle.

In sloping fields, a large distance will provide good stability.

4.3. POSITIONING STABILIZERS

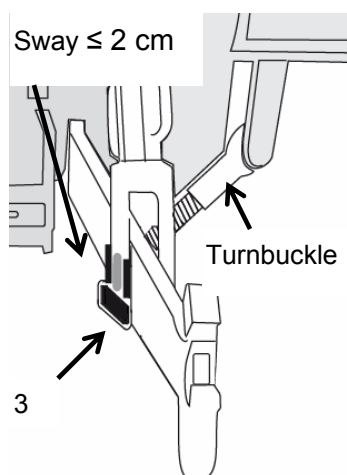

To hitch any tillage equipment on lower link arms, stabilizers shall be set so that arms have minimum lateral sway (≤ 2 cm) and are centred with tractor traction line. This will both prevent from any risk of shock during manoeuvre or road transport and keep machine lined up behind tractor at work.

Note : it is easier to adjust and / or service stabilisers bolts and threads before hitching the machine.

Horizontal lift links pins (3) shall be in fixed position to avoid any loose and / or damageable shock.

4.4. LIFT LINKS LENGTH

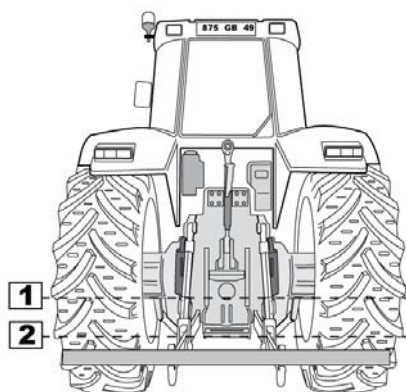

Lift link arms length determines tractor hitch levelling and lift cylinder position at working depth.

- Set lift links length so that tractor hitch is level (refer to picture).
- Set lift links length to have at least 30 mm clearance on lift cylinder rod when machine is working at desired depth. This will give adjustment possibilities for front gang depth from tractor's cab and allow efficient tractor draft control

4.5. FRONT END WEIGHTING

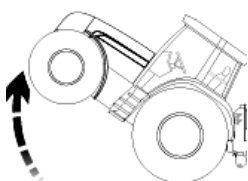

Wheels weights (front and rear) and front end weights may be required to avoid excessive slippage and to increase stability in rough and sloppy grounds.

Weights shall not be added once all slippage is eliminated. Refer to tractor operator's manual and to tractor's dealer. Follow tyre manufacturer's recommendations.

4.6. TOP LINK

Before attaching the machine, make sure that thread length is the same on both sides of top link. Refer to picture, A shall equal B.

Top link length will be adjusted in the field.

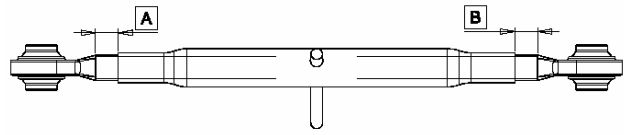

NOTE : an excess of grease inside top link tube may make it impossible to shorten. Remove grease fitting to let grease free to go out.

IMPORTANT : connection between machine and top link shall be done through a tie rod and never through an automatic hook.

- Automatic hooks sizes and designs change according to models and manufacturers and may cause interference with machine hitch in particular conditions.
- Spring shutter may block hitch ball which may wear or break. This is particularly true for hitches cat III : pin diameter is larger giving less quantity of matter for the ball becoming less strong.

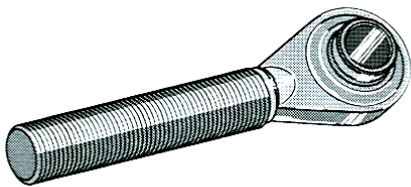

Example of tie rod
CORRECT

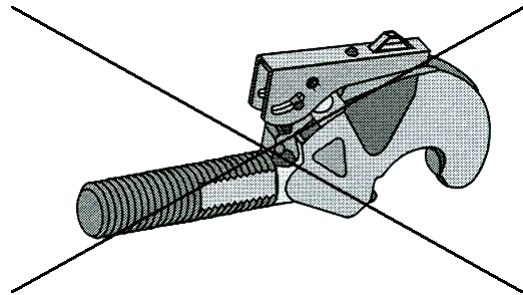

Example of automatic hook
DO NOT USE

Do not hesitate to contact an authorized Grégoire-Besson dealer for any further information.

5. ATTACHING AND DETACHING

Follow recommendations given in the safety section of this manual. They are not restrictive.

IMPORTANT : always make sure that hitching never leads to :

- overload : respect maximum admissible hitch load,
- unbalance: load tractor front end if necessary. Refer to point 4.5.

5.1. ATTACHING MACHINE TO TRACTOR

Before any manoeuvre, check for diameter and length compatibility between hitch pins and tractor tie rods.

5.1.1. Tractor equipped with tie rods lower links

- Remove safety bolts and hitch pins.
- Back up tractor to line up tie rods and machine hitch holes.
- Install pins and secure them with their safety clips.
- If holes are difficult to line up : extend telescopic arms as indicated in tractor operator's manual. Once hitch pins are inserted and secured with their safety clips, slowly back up tractor to lock back lift arms. Check for lift arms locking.
- Hitch top link.

5.1.2. Tractor equipped with automatic hooks lower links

- Remove safety bolts and hitch pins.
- Remove balls from tractor lift link automatic hooks.
- Install balls on pins through lower machine hitching holes. Secure with safety bolts.
- Slowly back up tractor till automatic hooks are lined up underneath hitch balls.
- Raise tractor hitch about 5 cm above ground surface till automatic hooks are locked.
- Check for automatic hooks latch handles good locking.
- Hitch top link.



IMPORTANT : make sure to have enough clearance between machine yoke hitch and tractor lower lift links to avoid any possibility of contact from working to raised position. A second verification shall be done once machine is in the field in truth working conditions.

5.1.3. Hitching top link

Connexion between top link and machine has to be done through a tie rod (refer to previous section).

Once tractor lift links are correctly hooked up, check top link general state and compatibility with tie rod. Then attach top link in upper yoke hitch.

Raise machine to the maximum and make sure there are no interference with tractor. Final top link adjustments (length and position) will be made in the field.

Do not forget to install safety clip back.



IMPORTANT : make sure to have enough clearance between machine yoke hitch and top link to avoid any contact from working to raised position. A second verification shall be done once machine is in the field in truth working conditions.

Connect hydraulic hoses.

5.2. DETACHING THE MACHINE

Before detaching, make sure that ground is flat and firm enough to support the machine. Use safety blocks to support machine components and / or parking stand if necessary.



DANGER : do not let any part of your body underneath the machine when lowering it to the ground.
Crushing may lead to death.

Proceed in the logical attaching opposite way :

- 1) Put machine in working position = it shall stay on its tines
- 2) Completely lower the machine to the ground,
- 3) Remove pressure and disconnect hydraulic lines
- 4) Detach top link and lower lift links.

NOTES

6. HYDRAULIC CONNEXIONS

Follow recommendations given in the safety section of this manual. They are not restrictive.

6.1. REQUIRED HYDRAULIC REMOTES

- 1 DA for hydraulic **vertical folding** (according to model).

6.2. HYDRAULIC CONNECTIONS

- Always wipe hydraulic couplers with a clean rag on both tractor and machine sides before connecting circuits.
 - Always check for machine hydraulic connectors and tractor remotes compatibility.
 - Logically connect hydraulic lines for the user :
- ⇒ Put most frequently used functions on closest lever
- ⇒ Watch for the way hydraulic flow is delivered : pull the lever to put machine in transport position (raise up / fold), push it to put machine in working position (lower / unfold).
- ⇒ Identify hoses using colour collars and signs (+ to extend rods, - to retract them).
- Check for hydraulic hoses length : too short they may break during sharp turns, too long they may interfere with tractor lift arms or tyres.

In case of any problem, do not hesitate to contact an authorized Grégoire-Besson dealer.

7. PREPARING THE MACHINE

Follow recommendations given in the safety section of this manual. They are not restrictive. For available accessories combinations possibilities refer to section 3.6.

7.1. ADJUSTING POINTS LOCALIZATION

Find adjusting points and check their lubrication and work. Doing this checking task close from a machine shop is better than doing it in the field.

7.1.1. Configuration Cultis + rear roller

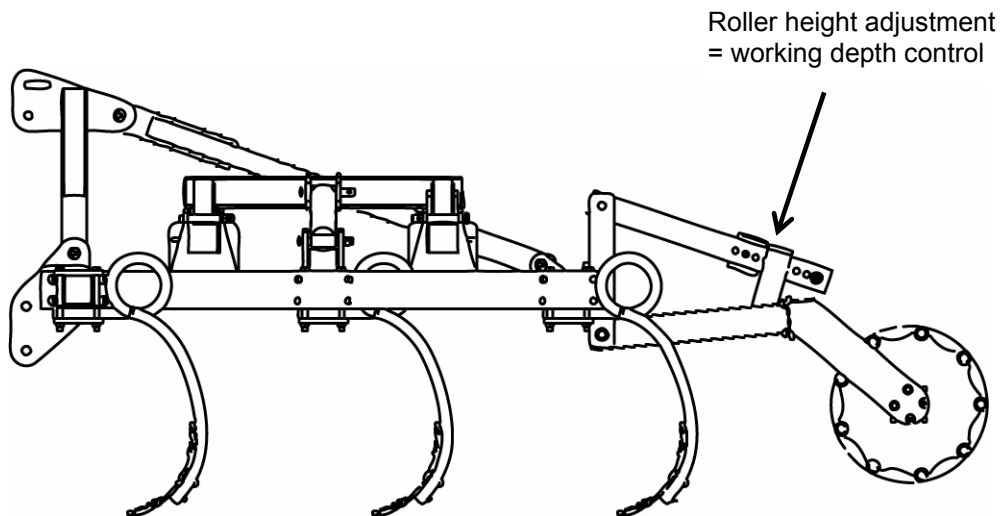

7.1.2. Configuration Cultis + gauge wheels

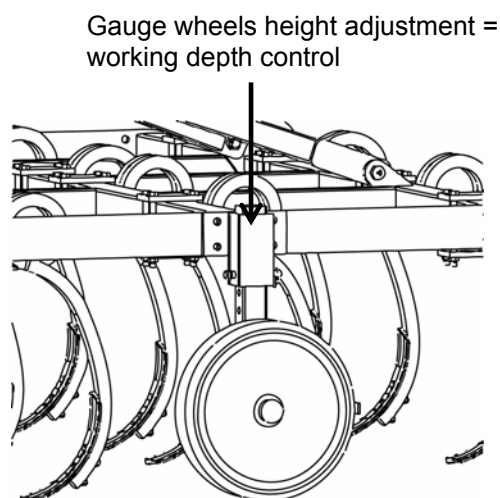

7.2. ADJUSTING REAR ROLLER

Each roller is set on the machine with two arms. The use of the roller controls working depth. This adjustment is done through sectors.

Roller height adjustment procedure

- On every single sector, remove safety clip and pin 1
- Change pin 1 position
 - => set it higher to increase working depth
 - => set it lower to decrease working depth
- Do not forget to install safety clip back
- **All sectors shall be adjusted the same for machine to work level.**
- Pin 2 sets roller stroke : the closer it is from pin 1, the shorter is roller stroke when lifting up the machine on headlands.

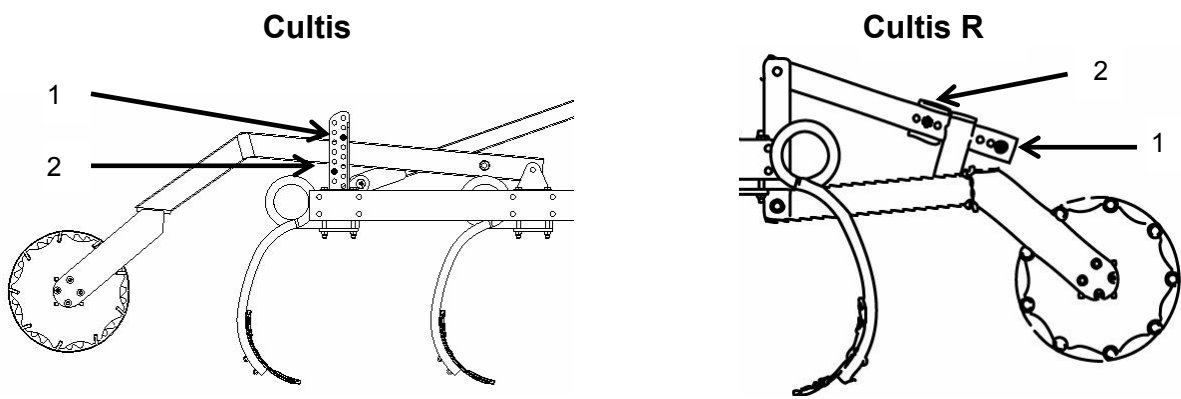

7.3. ADJUSTING GAUGE WHEELS

Machine shall be equipped with a pair of gauge wheels to control working depth.

- To **increase working depth, raise the wheels.**
- To **decrease working depth, lower the wheels.**
- **Both wheels shall be set the same for machine to work correctly.**

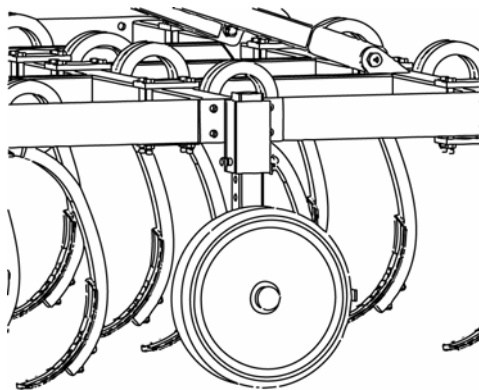

Wheels height adjustment procedure

- Stop tractor and raise the machine
- On each wheel mounting bracket,
 - => remove safety clip and pin
 - => slide wheel post through mounting bracket
 - => put pin back once desired position is reached. Do not forget safety clip.
- Lower the machine and check adjustment performance
- Change it if necessary.

8. TRANSPORTING

Follow recommendations given in the safety section of this manual. They are not restrictive.

8.1. CHANGING TO TRANSPORT POSITION

Before driving on a public road with the machine, put it in transport position :

- **Attach top link in a fixed hole.**
- **Raise machine to the maximum.**
- **Remove lateral wings working position locking pins** (foldable models only).
- **Fold lateral wings** (foldable models only).
- **Install transport position safety turnbuckle** (foldable models only).
- Lower the machine to lower gravity centre if necessary. Do not lower too much to avoid any contact with the ground.
- **In the cab lock all control levers** (hydraulic remotes, hitch, ...), to prevent any unforeseen movement and potential accident.
- **Install all lights, reflectors and signs required by current applicable law.**

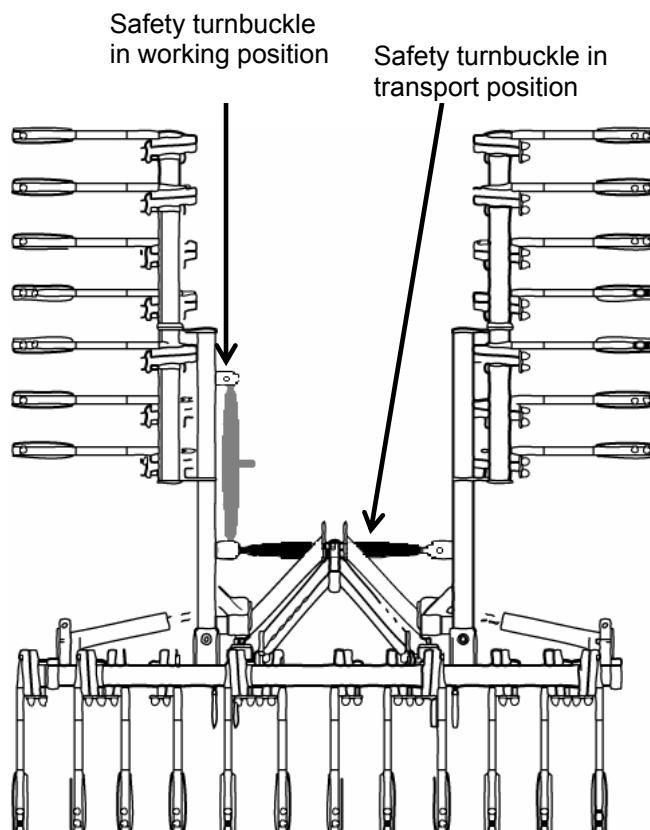

Cultis R folded in transport position

8.2. CHANGING TO WORKING POSITION

Follow here above described procedure in the opposite way.

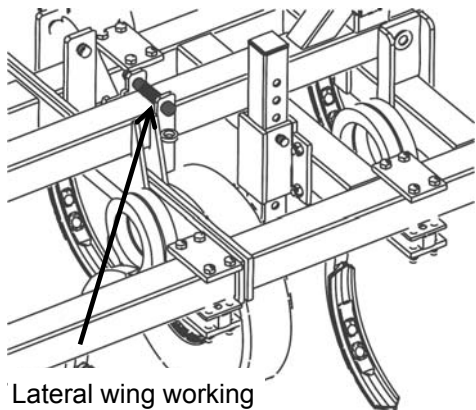

Lateral wing working position locking pin

- **Remove safety turnbuckle** before unfolding the machine (foldable models only).
- **Unfold lateral wings** (foldable models only).
- **Put safety turnbuckle in working position and install lateral wings working position locking pins** (foldable models only, refer to picture).
- Remove lights and signalization kits if necessary.

8.3. DRIVING ON PUBLIC ROAD

Before driving on a public road :

- **Be sure all signs, reflectors and lights required by local current law are in place, clean and visible to traffic.**
- Make sure there are no interferences between tractor and machine.
- Adopt a gentle attitude towards other public road users.

On public road, comply with local applicable laws :

- Tractor required for road transport shall equal the size and the horse power rating of the tractor used to work in the field.
- Do not drive over 25 km/h (= 15 mph).
- Drive at a reasonable speed to maintain complete control of both tractor and machine.
- Reduce speed on corners and on rough grounds.
- Do not drive down a hill faster than it could be possible to drive it up.
- Do not apply the tractor brakes to attempt a sharp turn.
- Always check wheel studs tightness before driving on a public road. They may get loose because of vibrations.
- Respect authorized maximum size for transport load (width, weight, length). For over sized loads, comply with current law taking all necessary precautions (signs, lights, escort, authorizations, ...).
- Respect the maximum wheel axle load and the maximum total driving load. Make sure front axle carries at least 20% of tractor's tare. Use front end weights if necessary.

ATTENTION : driving on public roads, operator is responsible for both tractor and equipment. He has to comply with current applicable law (getting in conformity with it and following its evolutions).

9. FIELD ADJSUTMENT

Follow recommendations given in the safety section of this manual. They are not restrictive.

9.1. FIELD UTILIZATION

Put machine in working position (refer to previous section).

To reach the best result, use machine with a slight angle regarding previous crop seeding line (15° to 30°). Operating speed shall be between 7 and 12 km / h (= 4.4 to 7.5 mph). this will allow :

- to prevent form any excessive track compaction,
- to improve trash flow, mixing and repartition of crop residue,
- to leave a levelled finish.

Always lift up machine before manoeuvring on headlands.

Never attempt a sharp turn with the machine in working position.

Slow down before manoeuvring or crossing any obstacle (ditch, ridge, rocky spot, ...).

IMPORTANT : before beginning field utilization, entirely read this chapter to understand all adjustments, their order and procedure.

IMPORTANT : always do one adjustment at a time. Then it is easier to check its performance and to change it if necessary.

9.2. CONFIGURATION CULTIS + ROLLER

9.2.1. Depth control and front to rear levelling

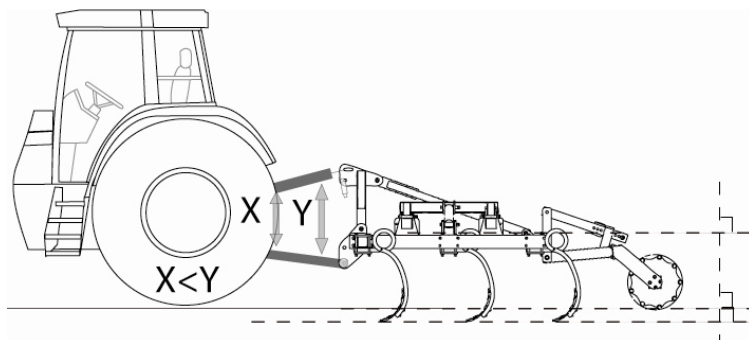

Top link shall be positioned in a fixed hole on machine yoke hitch. It shall be attached higher on machine side than on tractor side. At work once machine is lowered into the ground, put tractor's hydraulic lift height control lever on float position.

- Working depth is controlled by rear roller height (refer to section 7.2.).
- Machine main frame shall run levelled front to rear with the ground (refer to picture).

9.2.2. Side to side levelling

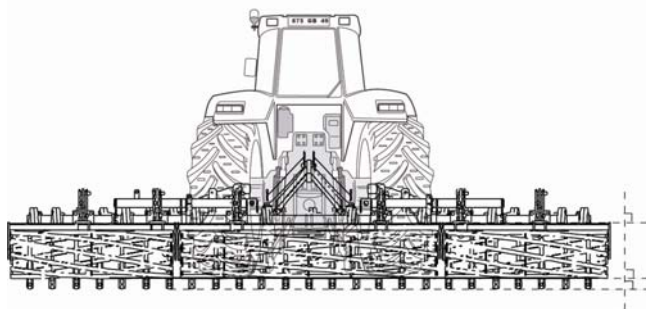

Machine main frame shall run levelled side to side with the ground (refer to picture). This is what happens in most conditions when :

- tractor's preparation has been correctly done : same tyre pressure on each side, tractor hitch levelled, stabilisation device installed, ...
- rear rollers all set at the same.

Note : when machine works at desired depth, take a few meters back to check its good levelling.

9.2.3. If ground is not levelled

If machine does not leave a perfectly flat surface, check and modify if necessary the following adjustments :

- machine levelling (front to rear and side to side),
- rear rollers adjustment (refer to section 7.2.).

9.3. CONFIGURATION CULTIS + GAUGE WHEELS

9.3.1. Depth control and front to rear levelling

Top link shall be positioned in a slot on machine yoke hitch. It shall be attached higher on machine side than on tractor side.

At work once machine is lowered into the ground, put tractor's hydraulic lift height control lever on float position.

- Working depth is controlled by gauge wheels height (refer to section 7.3.).
- Machine main frame shall run levelled front to rear with the ground.
- Top link length shall be set so that pin is free in the slot.

Particular conditions

In some particular conditions, light grounds for example, gauge wheels dig into the ground. It is then difficult to control working depth properly so part of the pressure shall be put on the tractor :

- attach top link in a fixed hole, always higher on machine side than on tractor side,
- set tractor hydraulic lift height and top link length so that machine runs parallel with the ground at desired speed and depth,
- to begin, set draft control on a minimum sensibility (10% to 20%), then once machine is properly set it could be increased.

9.3.2. Side to side levelling

Machine main frame shall run levelled side to side with the ground (refer to picture on previous page). This is what happens in most conditions when tractor's preparation has been correctly done : same tyre pressure on each side, tractor hitch levelled, stabilisation device installed.

Note : when machine works at desired depth, take a few meters back to check its good levelling.

NOTES

10. MAINTENANCE

Follow recommendations given in the safety section of this manual. They are not restrictive.

10.1. GENERAL INSTRUCTIONS



Operator and owner are responsible for good machine maintenance.



Inspect machine before and after each use. Repairs and service have to be done immediately so that they are not forgotten. Always leave the machine in a good state.

Cleaning the machine facilitates inspection. Check general state of machine, weldings, wheels studs, tyres, ...

Be careful with hydraulic lines : frictions may lead to excessive wearing and lines may leak. Never search a leak with your hands. Immediately replace any defective component. Spare components shall have the same characteristics.

Parts working in the ground may be sharpened and cause severe injury. Take particular care and use heavy leather gloves to remove them.

Never attempt any intervention on the machine while tractor engine is running.

Always properly secure all components before starting any maintenance operation underneath the machine.

Before using the machine for the first time, check all bolts tightness. Verify after 50 working hours and then at the beginning of each season. Pay special daily attention on wearing parts bolts and nuts tightness in rocky or dry conditions (lots of vibrations).

Wrong waste management is a danger for environment : collect waste oil, paint removers, accumulators, worn tyres ... Bring them back to a distributor or to an authorized collector. Do not let them in the nature.

10.2. LUBRICATION

A good lubrication of all moving parts will both allow the machine to work fine and insure its long-lasting.

Grease fittings are installed on all pivot points. Grease both lubricates moving parts and chases away abrasive dust or water that could come into pivot points.

Use quality grease, type Unil – Opal MS02 or equivalent.

Always wipe grease fittings with a clean rag before introducing grease. Do not hesitate to change any worn or broken grease fitting. Check for good grease course.

Remove all grease accumulation around grease fittings or moving parts.

Refer to grease fittings placement and frequency on the following drawing. Hard or intense conditions would require more.

The best is to grease regularly with regular quantity. Do not over grease.

Grease fitting placement	Frequency
Gauge wheels hubs (option)	50 h
Rear roller bearings (option)	20 h

10.3. SPARE PARTS

Genuine Grégoire-Besson parts have been specially designed and developed. Only the use of these parts will ensure proper fit, longevity and field quality work of the machine.



Using any other spare part than certified from Grégoire-Besson will void warranty.

Changing wearing parts too late may be source of poor quality work (penetration troubles, poor mixing ...) and may damage structure parts.

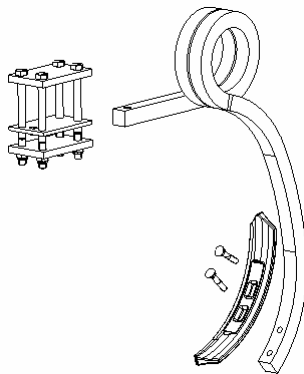

Tine 30 x 30 L.H. complete (edge + point)	M301015G
Tine 30 x 30 R.H. complete (edge + point)	M301015D
=> <i>picture shows a L.H. tine</i>	
Bracket for tine 30 x 30	E5300402
Screw H M12x90	BV129001
Lock nut M12	VJ322
Straight point 55 x 15	M320061
Wing share for straight point	7C00159
Bolt TFCC M12x65	BB126500

10.4. STORAGE SAFETY

- Before detaching the machine for storage, make sure ground is clean, flat and firm enough.
- Use parking stand and all other locking devices to prevent from any unforeseen movement during detachment or later on.
- Always store machine in working position (= unfolded).
- Block machine wheels to avoid any unforeseen movement.
- During storage, wheels shall not carry any weight.
- NEVER detach machine in raised position.
- Remove pressure from hydraulic circuit (engine shut off, shake hydraulic control lever in the cab).
- Store machine away from human activity.
- Store machine in a dry and dust free area (shed). Protect ram rods that cannot be retracted from rust using grease or oil.

CAUTION : never let children play around farm equipment.

ANNEX 1 – WEIGHT DISTRIBUTION

1. RESPECT WEIGHT DISTRIBUTION

Before hitching fully mounted equipments a tractor (front hitch and / or rear hitch), check the following points :

- do not exceed tractor maximum authorized weight,
- do not exceed maximum authorized weight on hitching points
- do not exceed maximum authorized weight on wheel axles
- do not exceed maximum authorized weight on tyres
- weight on front axle shall be at least 20 of unladen weight of the tractor

2. REQUIRED DATAS

Indicator	Data	How to find it ?
PV	Tractor unladen weight (kg)	Instructions manual or registration documents
	Tractor maximum authorized weight (kg)	Instructions manual or registration documents
	Maximum authorized weight on tractor front axle (kg)	Instructions manual or registration documents
P1	Tractor unladen weight on front axle (kg)	Instructions manual or registration documents
P1 _{cal}	Tractor real weight on front axle (kg)	Calculation
	Maximum authorized weight on tractor rear axle (kg)	Instructions manual or registration documents
P2	Tractor unladen weight on rear axle (kg)	Instructions manual or registration documents
P2 _{cal}	Tractor real weight on rear axle (kg)	Calculation
M1	Total front end weight or front implement weight (kg)	Front end specifications or front implement instructions manual
M2	Total rear implement weight (kg)	Implement instructions manual
a	Distance between front end weight (or implement) centre of gravity and the middle of front axle (m)	Instructions manuals or measurement
b	Distance between the middle of front and rear axles (m)	Instructions manual or registration documents
c	Distance between the middle of rear axle and rear hitching points (m)	Instructions manual or measurement
d	Distance between rear hitching points and rear implement centre of gravity (m)	Implement instructions manual

3. CALCULATIONS

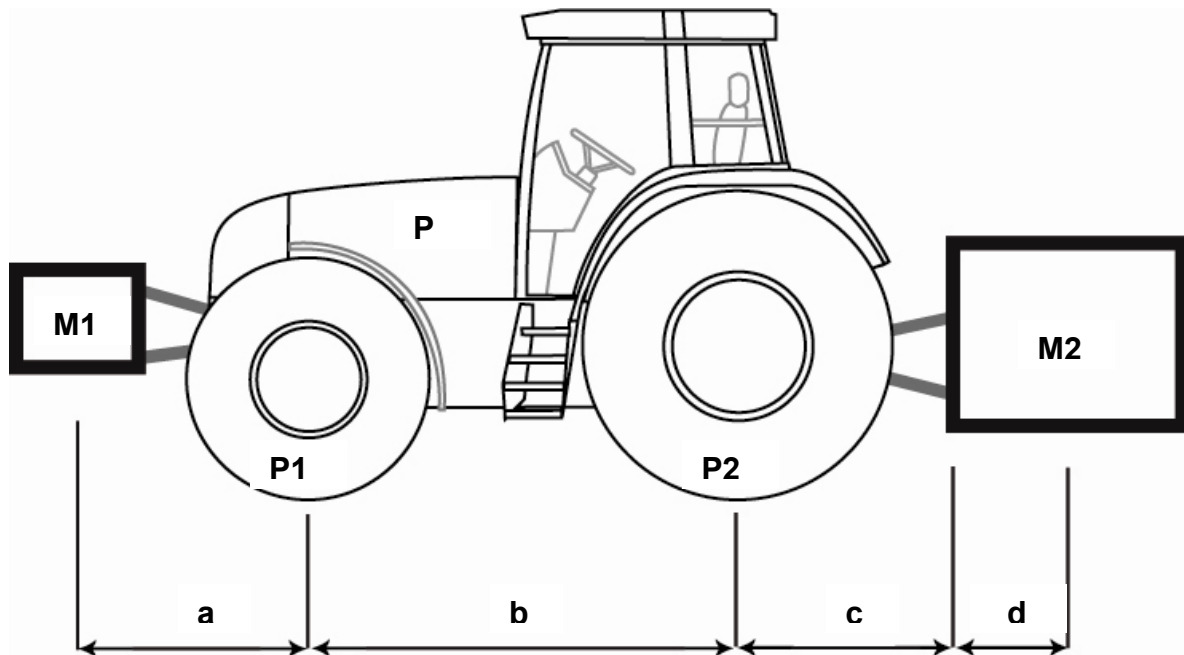

3.1. Minimum front end weighting calculation

$$M1_{\text{mini}} = \frac{M2 \times (c+d) - P1 \times b + 0.2 \times P \times b}{a + b}$$

3.2. Minimum rear end weighting calculation

$$M2_{\text{mini}} = \frac{M1 \times a - P2 \times b + 0.45 \times P \times b}{b + c + d}$$

3.3. Real over all weight calculation

$$PT_{\text{réel}} = PV + M1 + M2$$

3.4. Real front axle weight calculation

$$P1_{\text{cal}} = \frac{M1 \times (a+b) + P1 \times b - M2 \times (c+d)}{b}$$

3.5. Real rear axle weight calculation

$$P2_{\text{cal}} = PT_{\text{réel}} - P1_{\text{cal}}$$

NOTES

QUICKLY STARTING - CULTIS & CULTIS R

Take all precautionary measures. Respect safety recommendations.

PREPARING THE TRACTOR

- 1. Check tyre pressure**
It should be the same on both sides on each axle.
Always follow tyre manufacturer recommendations.
- 2. Adjust tractor hitch levelling**
Set lift links length for tractor hitch to be perfectly level with the ground.
Arms shall be long enough so that working at desired depth there is still 30 mm chrome visible on lift ram.
- 3. Adjust lift links sway**
Lateral sway minimum (≤ 2 cm)
- 4. Check top link**
Connexion between top link and machine must be done through a tie rod and not through an automatic hook.

HITCHING

- 5. Attach lower link arms and top link**
- 6. Make sure there are no interferences between machine and tractor from raised position to working position**
Machine shall never come in contact with tractor.
There should be no contact between tractor lift links and machine yoke hitch.
- 7. Connect hydraulic lines (foldable models only)**
- 8. Transport / working positions**

Transport position	top link in a fixed hole, machine raised high enough to prevent any contact with the ground, but not too much to let visibility, lateral wings folded, safety turnbuckle in transport position, control lever locked in the cab
Working position	safety turnbuckle removed, lateral wings unfolded and locked in working position, hydraulic control lever on float position

FIELD ADJUSTMENT

- 9. Machine shall be parallel with the ground at desired depth and speed**

Side to side levelling	tractor hydraulic lift arms length machine accessories (rollers or gauge wheels)
Front to rear levelling	machine working depth controlling devices (roller or gauge wheels) tractor hydraulic lift height top link length and position

MAINTENANCE

- 10. Follow recommendations given in this manual according to lubrication and maintenance of the machine**

GRÉGOIRE  **BESSON**

**49230 MONTFAUCON-MONTIGNÉ-SUR-MOINE
FRANCE**

TÉL. (+33) (0)2 41 64 72 67

FAX (+33) (0)2 41 64 67 73

GRÉGOIRE-BESSON UK

Bourne Road, Carlby - STAMFORD LINCS PE9 4 NG – ENGLAND
phone (44) 01 778 590 223 - Fax (44) 01 778 590 645

GRÉGOIRE-BESSON CANADA INC

4480, Rue Martineau - ST-HYACINTHE (P. Québec) - CANADA J2R 1V1
TÉL. (1) 450 799 56 15 - FAX (1) 450 799 56 29

GRÉGOIRE-BESSON POLSKA

Ul. Obornicka 1a - PL - 64 600 OBORNIKI - Polska
TEL/FAX : (061) 29 77 530
gbesson@poczta.onet.pl
Ruda 12 - PL - 64610 ROGOZNO – TÉL / FAX (48) (67) 261 97 79

ООО «ГРЕГУАР-БЕССОН ВОСТОК»

Россия 308018 г. Белгород,
ул. Корочанская, 132а
Тел/факс: +7(4722) 58 70 36, 58 70 35
E-mail: info@gbvostok.ru

法国格力格尔 - 贝松公司北京代表处
北京市朝阳区延静里中街3号 长信大厦 220室
邮编：100025

WEB : www.gregoire-besson.fr E.MAIL : Contactfr@gregoirebesson.fr