

GRÉGOIRE  **BESSON**

HELIOS

Twin beam subsoiler not foldable

OPERATOR'S MANUAL MAINTENANCE INSTRUCTIONS

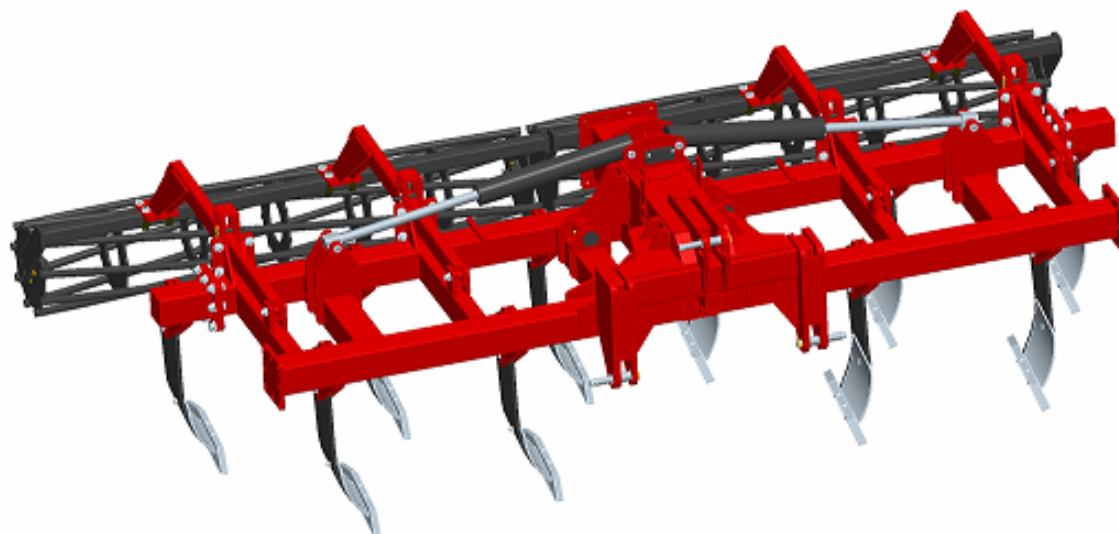

GRÉGOIRE-BESSON S.A.

Rue Victor Grégoire
49 230 MONTFAUCON – MONTIGNÉ
France

Phone : 33 (0) 2 41 64 72 67
Fax : 33 (0) 2 41 64 67 73

Web : www.gregoire-besson.com
Email : Contactfr@gregoirebesson.com

September 2008

TABLE OF CONTENTS

1. INTRODUCTION	3
2. SAFETY INSTRUCTIONS	4
2.1. SAFETY STICKERS	4
2.2. SAFETY WHILE ATTACHING AND DETACHING	6
2.3. SAFETY WHILE CONNECTING HYDRAULIC LINES	6
2.4. SAFETY WHILE OPERATING MACHINE	6
2.5. SAFETY FOR MAINTENANCE	7
2.6. SAFETY FOR ON HIGHWAY TRANSPORT	7
3. MACHINE DESCRIPTION	8
3.1. IDENTIFICATION VIEWS	8
3.2. « MICHEL » TINE	9
3.3. TECHNICAL SPECIFICATIONS	10
3.4. DIMENSIONS AND WEIGHTS	10
3.5. OPTIONAL EQUIPMENTS	11
<u>3.5.1. Gauge wheels</u>	11
<u>3.5.2. Rear roller</u>	11
<u>3.5.3. Tip Top point</u>	11
<u>3.5.4. Lights and signs kits</u>	11
<u>3.5.5. Lateral extensions</u>	11
4. PREPARING THE TRACTOR	12
4.1. REQUIRED HORSE POWER	12
4.2. TRACTOR TYRES	12
4.3. POSITIONING STABILISERS OR SWAY BLOCKS	12
4.4. LIFT LINKS PINS	13
4.5. LIFT LINKS LENGTH	13
<u>4.5.1. Tractor hitch levelling</u>	13
<u>4.5.2. Lift cylinders position</u>	13
4.6. TOP LINK	14
4.7. FRONT END WEIGHTING	14
5. ATTACHING AND DETACHING	15
5.1. ATTACHING MACHINE TO TRACTOR	15
<u>5.1.1. Tractor equipped with tie rods lower links</u>	15
<u>5.1.2. Tractor equipped with automatic hooks lower links</u>	15
<u>5.1.3. Hitching top link</u>	16
5.2. DETACHING THE MACHINE	16
6. HYDRAULIC CONNEXIONS	17
6.1. REQUIRED HYDRAULIC COUPLERS	17
6.2. HYDRAULIC CONNECTIONS	17
6.3. HYDRAULIC PRESSURE IN NON-STOP SAFETY DEVICE (OPTION) ...	17

7. DRIVING ON PUBLIC ROAD	18
8. FIELD ADJUSTMENT	18
8.1. USING HELIOS	18
8.2. ADJUSTING THE MACHINE	19
<u>8.2.1. Depth control and front to rear levelling</u>	19
<u>8.2.2. Weight transfer</u>	19
<u>8.2.3. Side to side levelling</u>	19
8.3. MACHINE EQUIPPED WITH GAUGE WHEELS (OPTION)	20
8.4. MACHINE EQUIPPED WITH REAR ROLLER (OPTION)	20
9. MAINTENANCE	21
9.1. GENERAL INSTRUCTIONS	21
9.2. SPARE PARTS	21
9.3. CHANGING WEARING PARTS	22
9.4. LUBRICATION	22
9.5. ADDING OR REMOVING LATERAL EXTENSIONS	23
10. QUICKLY STARTING HELIOS	25

Any use and / or reproduction of all or part of this manual without written authorization from Grégoire-Besson is strictly prohibited.

1. INTRODUCTION



READ CAREFULLY THIS MANUAL



To properly start, operate and service your equipment, follow all instructions given in this manual.

THIS MANUAL SHOULD BE CONSIDERED AS A PART OF THE EQUIPMENT AND SHOULD FOLLOW IT WHEN YOU SELL IT.

LEFT HAND SIDE AND RIGHT HAND SIDE, FRONT AND REAR are determined looking from equipment towards tractor when in work.

ALL INFORMATIONS, PICTURE, SPECIFICATIONS in this manual are based on the newer information available at the time of publication. Pictures and drawings might not represent standard equipment and show optional attachments.

Manufacturer reserves right to make any changes at all time **without any obligation to notice or to modify any delivered or already sold machine.**

If the machine has been modified in any way from the original design without written agreement from GREGOIRE-BESSON, the manufacturer does not accept any liability for injury or warranty. Warranty would become void.



This symbol is used in the following manual to **catch your attention on warnings concerning your safety.**

So please when you see it in this manual or on the equipment, **strictly follow given information.**

GREGOIRE-BESSON equipments are exclusively designed to be used for regular farm tillage in farmed fields. Manufacturer shall not be responsible for damage or injury resulting from any other use.

PRODUCT IDENTIFICATION NUMBER

Please record here purchasing date, model and serial number of your equipment (refer to identification plate on hitch). Always refer to these information to get prompt and good service.

Purchasing date :

Model :

Serial number :

Salesman's phone :

2. SAFETY INSTRUCTIONS

2.1. SAFETY STICKERS



READ OPERATOR'S MANUAL

Read operator 's manual and safety instructions before starting the use of your equipment and follow them while using.



Reference : UI 129



UNFOLDING AREA

Stay clear of equipment when folding or unfolding.

Reference : UI 126



MOVE AWAY FROM THE MACHINE

Danger in the working area, stay clear from the machine.

Reference : UI 127

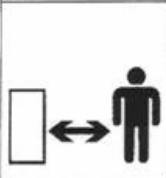

SECURE THE MACHINE BEFORE ACTION

Always install all lockup devices to secure machine before any intervention on it.

Reference : UI 131



HYDRAULIC LEAK AND MAINTENANCE

Caution, high pressure fluids can cause injury. Follow safe practices.

Reference : UI 128



Positioning safety stickers on the machine

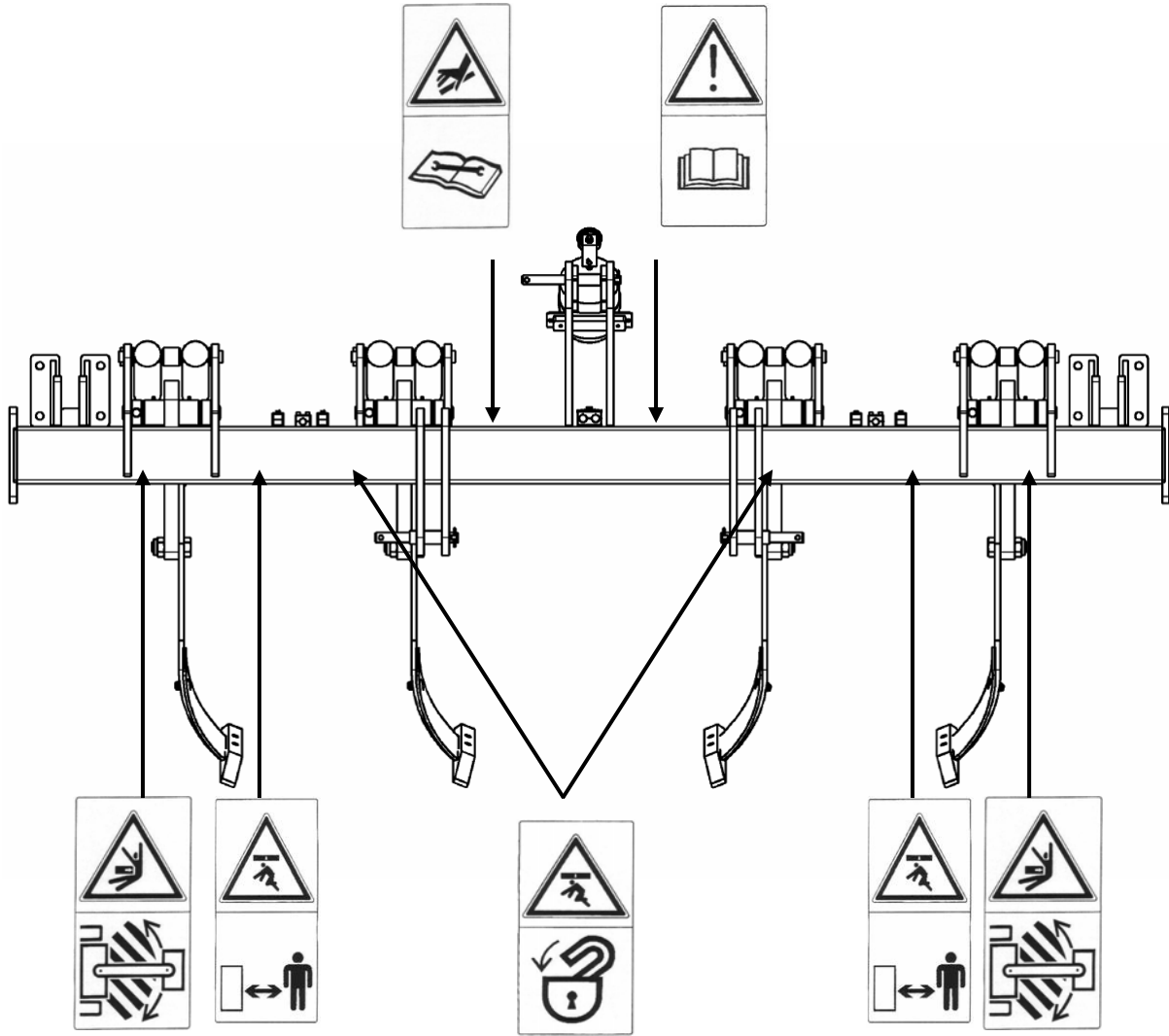

2.2. SAFETY WHILE ATTACHING AND DETACHING



- Do not let **anyone to stand between the machine and the tractor** when you back up to hitch.
- Before leaving the tractor to hitch or unhitch, set tractor parking brakes.
- Do not try to hitch the machine if you do not have the right size pins (diameter and length shall be compatible between both tractor and machine).
- Completely lower the machine to the ground before unhitching. Make sure it is on a level and firm surface.
- Remove pressure from hydraulic lines before disconnecting them.
- Before leaving the machine for storage, make sure it is in a safe place and that there is no risk to damage whether anything or anyone.

2.3. SAFETY WHILE CONNECTING HYDRAULIC LINES



- Hydraulic circuit might be highly pressurised.
- **Never use your hands to locate a hydraulic leak.** Hydraulic fluids escaping under pressure have sufficient force to penetrate the skin, causing severe injury. In case of any injury, **see a doctor immediately.**
- For equipments loaded with several hydraulic connectors, **make logical and appropriated connections.**
- Before connecting hydraulic circuit, **make sure that there is no pressure on both sides (tractor and machine).**
- Regularly check hydraulic lines and connections. **Replace any damaged or leaking component** by an original part with the same specifications.
- Before any intervention on hydraulic circuit, **lower machine to the ground and release pressure moving control lever in the tractor's cab.**

2.4. SAFETY WHILE OPERATING MACHINE

- **Never attempt** any intervention on the machine while it is in motion.
- Wear close **fitting clothing** and **appropriate safety devices** for the job you have to do (heavy leather gloves, safety shoes, earplugs, ...).
- Do not allow anyone to stand close to the machine.
- Do not attempt to do any adjustment if you have not perfectly understood its procedure.
- Always use tools or equipments appropriate to the job you are doing. All GREGOIRE-BESSON equipments are metric standards.
- Learn how to operate your machine and how to use its controls. Do not let anyone operate without instruction.
- Only one person (the operator) should be in the tractor's cab when it is in operation. **No one on the machine while working or travelling on the road.**



If your machine is equipped with a hydraulic folding mechanism, **always use it from tractor's cab, once you are sure that folding area is free from spectators or obstacles.**

2.5. SAFETY FOR MAINTENANCE



During maintenance operation, comply with the following rules

- Maintenance area shall be **clean, dry, with enough light and ventilation.**
- For any intervention on the machine in raised position, **always securely support all components** before starting maintenance.
- After servicing remove all tools, components and parts you used.
- Regularly check tightness of wheel studs, tine bottom studs, and other bolts and nuts.
- **Always use genuine parts corresponding to manufacturer's technical specification requirements.**

2.6. SAFETY FOR ON HIGHWAY TRANSPORT



FOR YOUR OWN SAFETY AND THE ONE OF THE OTHER, RESPECT THE FOLLOWING RULES :

- All GREGOIRE-BESSON equipments shall be used **complying with area's current rules and laws** concerning **safety instructions, accident prevention** and **provision of Highway Code.**
- Always **check for wheels studs tightness before road transport.**
- **Use all devices required by your area's current laws** (lights, reflectors, signs, ...). You might remove them in during field operation to prevent from any damage. It is the operator's responsibility to comply with current law and to follow its evolutions.
- Regularly check hitching pins, change them if necessary. Tractor's ball joint may also wear, do not hesitate to replace them with new ones having at least Waltersheid fabrication quality.
- Drive **at reasonable speed** complying with local laws **to always keep control** of tractor and equipment. Pay special attention on irregular or rough roads. **Do not attempt to drive down a hill faster than it could be possible to drive it up.**
- **Never attempt any manoeuvre if area is not free from spectators.**
- If your machine is equipped with a **folding mechanism** (manual or hydraulic), **use it making sure folding area is free from spectators** and obstacles.
- Follow all **safe driving practices** when travelling, moreover **on corners, rough or narrow roads.**
- When **leaving tractor** even for a short period, **shut off engine, remove ignition key and set parking brakes.**
- Forbid anyone to stand between tractor and machine or on the machine travelling on the road.

3. MACHINE DESCRIPTION

3.1. IDENTIFICATION VIEWS

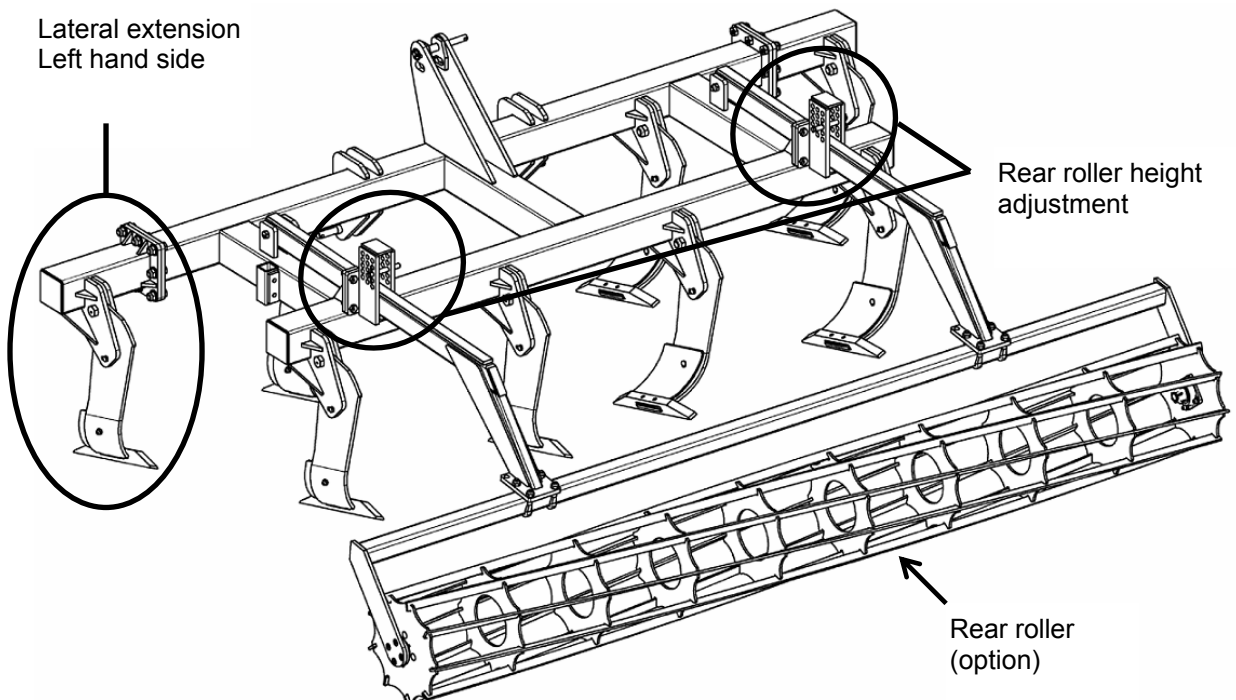
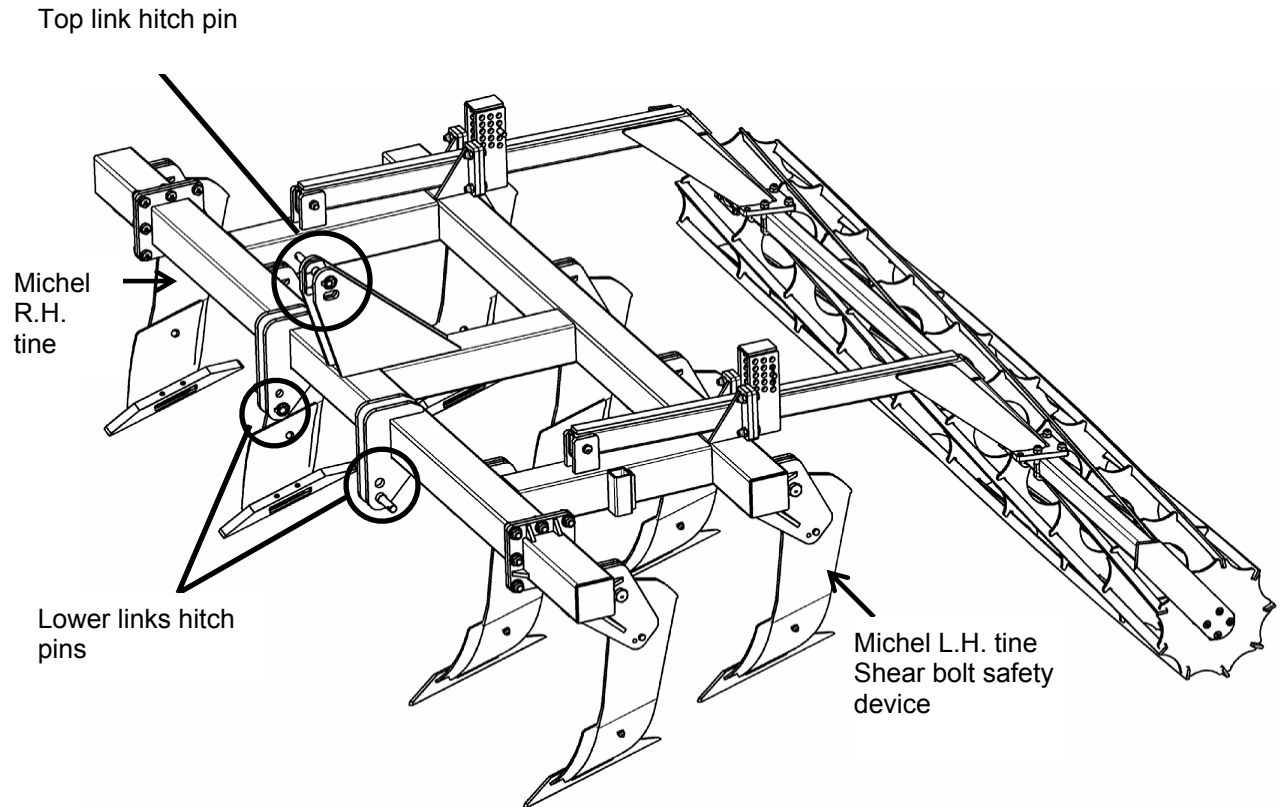

3.2. « MICHEL » TINE

Shear bolt safety device

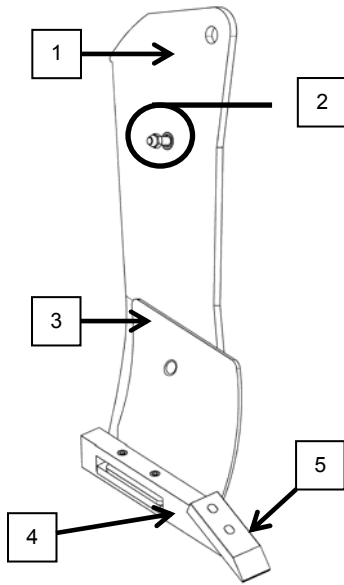

Non-Stop Hydraulic Safety device

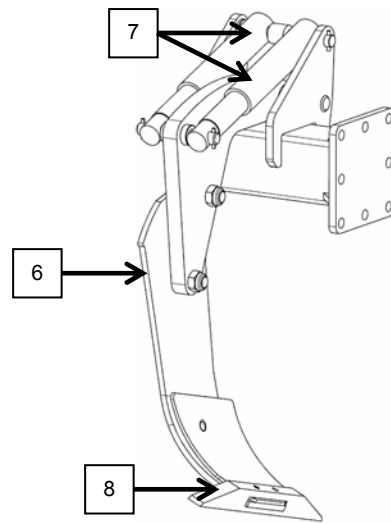

1. Heliplow twisted tine shear bolt safety device
2. Shear bolt
3. Heliplow counter blade
4. Heliplow point support only
5. Heliplow bolted point (standard assembly)

6. Heliplow twisted tine NSH
7. Safety cylinders
8. Reversible share (option)

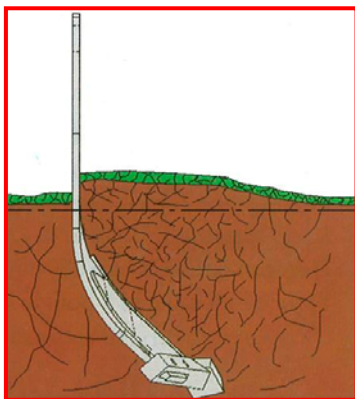

Michel tine works in deep. It loosens the ground without any lay mixing.

Tine passage creates a “wave effect” responsible of ground fissuring all along worked depth. On the surface, it seems that nothing changed : no clods or rocks climbing, top soil and trash stays on top. Erosion and water run-off risks are avoided.

Tine is equipped with a point bolted on a tilted support. It can be used in all conditions without any risks of compaction lay creation.

In a loose and aerated soil, water and air circulation is improved, crop implanting is easier.

3.3. TECHNICAL SPECIFICATIONS

Specification	Standard equipments	Optional equipments
3 points linkage	<ul style="list-style-type: none"> In yoke Ø II and III, width III 	
Frame	<ul style="list-style-type: none"> Main frame twin beam 160 x 160 mm 	<ul style="list-style-type: none"> Pair of gauge wheels tyres 200 x 14.5 Boltable lateral extensions for 3.00 m frame
Clearance between beams	<ul style="list-style-type: none"> 700 mm 	
Underbeam clearance	<ul style="list-style-type: none"> 900 mm 	
Working tines	<ul style="list-style-type: none"> Tine support welded Curved tines type « Michel » in special treated steell Bolted point on tilted support 	<ul style="list-style-type: none"> Carbide bolted point on tilted support Reversible share Tip-top point (= quick change) on tilted support
Safety device	<ul style="list-style-type: none"> Shear bolt (T) or non stop hydraulic (NSH) with 2 cylinders per tines 	
Rear accessories		<ul style="list-style-type: none"> Rear crumbler roller tube or full metal bar, Ø 500 or 600 mm Twin roller

A large choice of options is available to improve machine's job.

Grégoire-Besson authorized dealers know area and working conditions. They may give information according to technical choices and latest equipments evolutions.

Grégoire-Besson is also represented on farm equipment shows.

3.4. DIMENSIONS AND WEIGHTS

Nb of blades	Safety device	Working Width	Transport Width	Indicative weight
4	B	2.00 to 3.00 m	3.00 m	830 kg
6	B	3.00 m	3.00 m	980 kg
6	B	3.00 to 4.00 m	4.00 m	1 130 kg
8	B	4.00 m	4.00 m	1 240 kg
4	NSH	2.80 m	3.00 m	1 100 kg
6	NSH	3.00 m	3.00 m	1 340 kg
8	NSH	4.00 m	4.00 m	1 720 kg

Dimensions and weights are indicative and subject to variations according to equipments and options.

NOTE : after use, ground or residue accumulations may increase machine's weight.

3.5. OPTIONAL EQUIPMENTS

3.5.1. Gauge wheels



One pair of gauge wheels can be added on the machine. Using the wheels improves field stability and can control working depth.

Gauge wheels are equipped with tyres :

- 200 x 14.5, AW radial profile, Ø 610 mm, width 210 mm, max pressure : 5 bars, follow manufacturer's recommendations.

3.5.2. Rear roller



A rear roller can be added on the machine. Different profiles are available according to desired finishing :

- Crumbler roller tube or full metal bar (not shown) : improves machine's field stability, controls working depth, levels ground surface.
- Twin roller (refer to picture) : a double row of wavy disks works ground surface, improving mixing and organic matter decomposition

3.5.3. Tip Top point

This wearing parts assembly allows fast and easy changing of points (= Quick Change system).

3.5.4. Lights and signs kits

Lights and signs kits are available for all Grégoire-Besson equipments. Contact an authorized dealer.

3.5.5. Lateral extensions

Lateral extensions are available to turn a 3.00 m frame into a 4.00 m

Note : for machine equipped with a rear roller, adding extensions requires changing roller. The 3.20 m wide roller used on the 3.00 m frame will not cover the full working width of a 4.00 m frame.

Contact an authorized Grégoire-Besson dealer.

4. PREPARING THE TRACTOR

Follow recommendations given in the safety section of this manual. They are not restrictive.

4.1. REQUIRED HORSE POWER

Tractor requirements may vary according to ground and working conditions (type of soil, type of tractor, type of tyres, ...). Following data are only indicative. Ask an authorized Grégoire-Besson dealer for any further information.

Number of tines	Working width	Required HP (average)
4	2.00 to 3.00 m	80 / 120 cv
6	3.00 to 4.00 m	120 / 200 cv
8	4.00 m	150 / 240 cv

**shear bolt safety device only*

4.2. TRACTOR TYRES

Check tractor tyres general state and pressure. Pressure should be the same on both sides of the tractor for a nice drivability in the field and on the road.

Follow manufacturer's recommendations.

4.3. POSITIONING STABILISERS OR SWAY BLOCKS

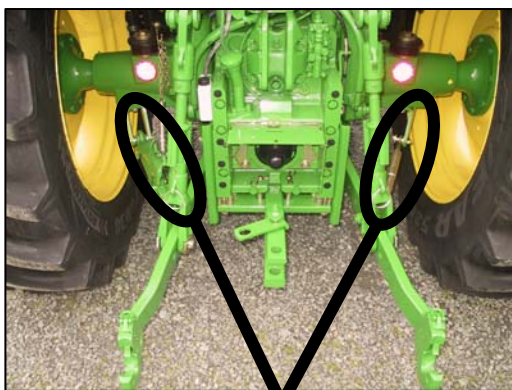

STABILISER

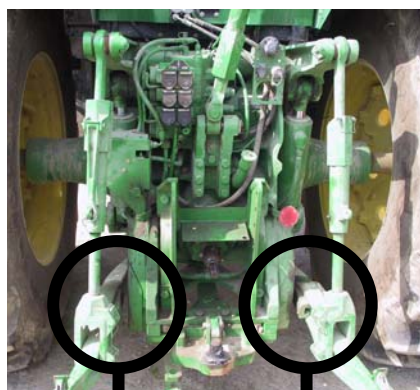

BLOCKS

Sway blocks or turnbuckle stabilizers shall be positioned in order to reduce lateral swing of lower lift links to a minimum (good if $\leq 1 \text{ cm} \approx 1/2''$) when machine is hooked up.

Too much sway for lift link arms would result in shocks between machine and tractor hitch while manoeuvring or transporting.

If there is still too much swing even with stabilizer system installed, do not hesitate to put bushings on hitch pins. Verify good compatibility between bushings and pins (\varnothing and length).

NOTE : it is easier to adjust and / or service stabilisers bolts and threads before hitching the machine.

4.4. LIFT LINKS PINS

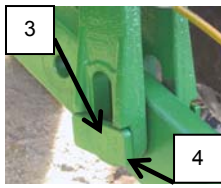

Horizontal lift links pins (3) shall be in fixed position (4) to avoid any loose and / or damageable shock.

4.5. LIFT LINKS LENGTH

Lift links length determines :

- tractor hitch levelling, so machine side to side levelling,
- lift cylinders position at working depth, so draft control efficiency.

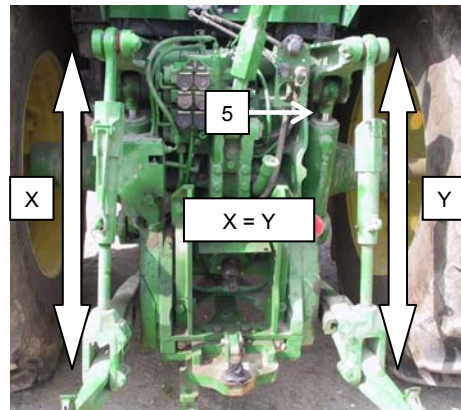
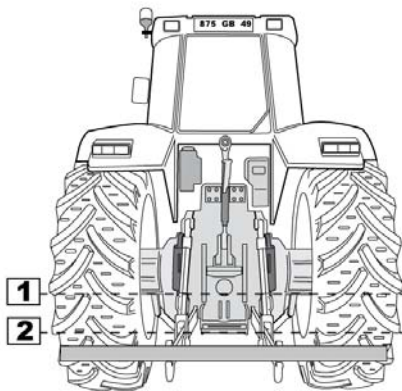

4.5.1. Tractor hitch levelling

Set lift links length so that tractor hitch is perfectly level (refer to left hand picture). This way, once attached, machine will work perfectly level, at the same depth on each side.

Procedure for this adjustment :

- check that the two lift link arms have the same length (refer to right hand picture),
- put a flat bar on lower links, back up a few meters and check for its alignment with other points on the tractor as rear wheels spindle (1) or lift links support brackets (2) (refer to left hand picture),
- if flat bar is not strictly level, adjust lift links length to level it.

4.5.2. Lift cylinders position

Lift cylinders position at working depth is related to lift links length. Tractor depth control will work better if lift cylinder rods have enough clearance to move (= to extend or to retract according to pressure).

Set lift links length to have at least **30 mm clearance on lift cylinder rod (5) when machine is working at desired depth.**

Pay particular attention on this point when using a tractor equipped with large diameter wheels.

4.6. TOP LINK

Before attaching the machine, make sure that thread length is the same on both sides of top link. Refer to picture, A shall equal B.

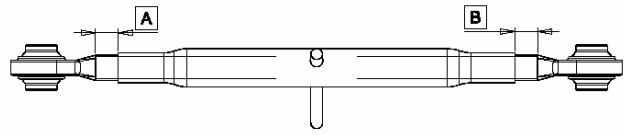

Top link length will be adjusted in the field.

NOTE : an excess of grease inside top link tube may make it impossible to shorten. Remove grease fitting to let grease free to go out.

IMPORTANT : connection between machine and top link shall be done through a tie rod and never through an automatic hook.

- Automatic hooks sizes and designs change according to models and manufacturers and may cause interference with machine hitch in particular conditions.
- Spring shutter may block hitch ball which may wear or break. This is particularly true for hitches cat III: pin diameter is larger giving less quantity of matter for the ball becoming less strong.

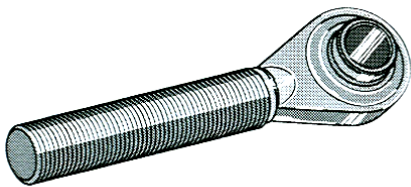

Example of tie rod
CORRECT

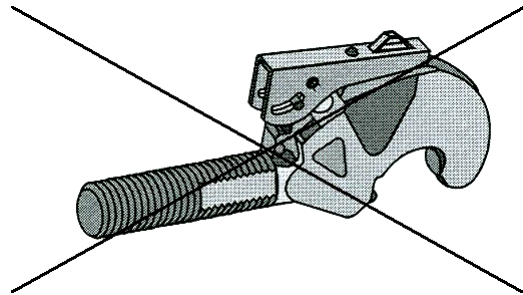

Example of automatic hook
DO NOT USE

Do not hesitate to contact an authorized Grégoire-Besson dealer for any further information.

4.7. FRONT END WEIGHTING

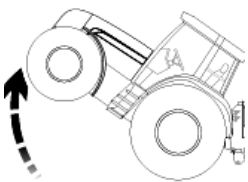

Wheels weights (front and rear) and front end weights may be required to avoid excessive slippage and to increase stability in rough and sloppy grounds.

Weights shall not be added once all slippage is eliminated. Refer to tractor operator's manual and to tractor's dealer. Follow tyre manufacturer's recommendations.

5. ATTACHING AND DETACHING

Follow recommendations given in the safety section of this manual. They are not restrictive.

IMPORTANT : never attempt to attach the machine if pins or tractor hitching balls are worn or not compatible.

5.1. ATTACHING MACHINE TO TRACTOR

5.1.1. Tractor equipped with tie rods lower links

- Before any manoeuvre, check for diameter and length compatibility between hitch pins and tractor tie rods.
- Remove safety pins clips and hitch pins.
- Back up tractor to line up tie rods and machine hitch holes. Always first try to hitch machine as low as possible. In a second time, according to conditions (lift links length, wheels diameter, ...) other possibilities may be tried.
- Install pins and secure them with their safety clips.
- If holes are difficult to line up : extend telescopic arms as indicated in tractor operator's manual. Once hitch pins are inserted and secured with their safety clips, slowly back up tractor to lock back lift arms. Check for lift arms locking.
- Hitch top link.

5.1.2. Tractor equipped with automatic hooks lower links

- Remove safety clips and hitch pins.
- Remove balls from tractor lift link automatic hooks.
- Check for balls and pins general state and compatibility.
- Install balls on pins through lower machine hitching holes. Secure with safety clips.
- Slowly back up tractor till automatic hooks are lined up underneath hitch balls.
- Raise tractor hitch about 5 cm above ground surface till automatic hooks are locked.
- Check for automatic hooks latch handles good locking.
- Hitch top link.



IMPORTANT : before hitching top link, **make sure to have enough clearance between machine yoke hitch and tractor lower lift links to avoid any possibility of contact from working to raised position.**

5.1.3. Hitching top link

Connexion between top link and machine has to be done through a tie rod (refer to previous section).

Once tractor lift links are correctly hooked up, check top link general state and compatibility with tie rod. Then attach top link in one of the two holes : **fixed hole for road transport**, or **slot for field operation** using gauge wheels or rear roller.

Raise machine to the maximum and make sure there are no interference with tractor. Final top link adjustments (length and position) will be made in the field.



IMPORTANT : make sure to have enough clearance between machine yoke hitch and top link to avoid any contact from working to raised position.

5.2. DETACHING THE MACHINE

Before detaching, make sure that ground is flat and firm enough to support the machine. Use safety blocks to support machine components if necessary.



DANGER : do not let any part of your body underneath the machine when lowering it to the ground.

Crushing may lead to death.

Proceed in the logical attaching opposite way :

- 1) Completely lower the machine to the ground,
- 2) Detach top link
- 3) Disconnect hydraulic lines (only for machine equipped with NSH safety device)
- 4) Detach lower lift links

Always operate with care.

6. HYDRAULIC CONNEXIONS

Follow recommendations given in the safety section of this manual. They are not restrictive.

6.1. REQUIRED HYDRAULIC COUPLERS

- 1 SA remote for hydraulic Non-Stop safety device (option).

6.2. HYDRAULIC CONNECTIONS

- Always wipe hydraulic couplers with a clean rag on both tractor and machine sides before connecting circuits.
- Always check for machine hydraulic connectors and tractor remotes compatibility. In case of incompatibility contact an authorized Grégoire-Besson dealer.
- Logically connect hydraulic lines for the user :
 - ⇒ Put most frequently used functions on closest lever
 - ⇒ Watch for the way hydraulic flow is delivered : pull the lever to put machine in transport position (raise up / fold), push it to put machine in working position (lower / unfold).
- Check for hydraulic hoses length : too short they may break during sharp turns, too long they may interfere with tractor lift arms or tyres. In case of any problem, contact an authorized Grégoire-Besson dealer.

6.3. HYDRAULIC PRESSURE IN NON-STOP SAFETY DEVICE (OPTION)

In regular conditions, pressure in hydraulic circuit shall be set from **60 to 110 bars** which corresponds to the green area on the pressure gauge. **Always stay in this window.**

Adjustment procedure :

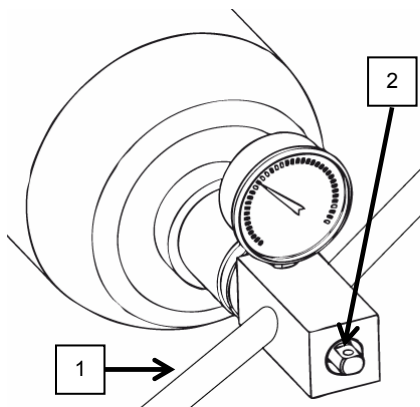

- Correctly connect hydraulic hose (1) to the tractor.
- Open valve (2) situated on the front of the machine.
- To **increase safety device resistance**, increase hydraulic pressure in the system **adding oil**.
- To **decrease safety device resistance**, decrease hydraulic pressure in the system **removing oil**.
- Once desired pressure is reached, shut valve (2). Then hydraulic hose (1) may be disconnected.

Clever way for an operator alone in the field :

- Connect hydraulic hose (1), open valve (2) and add more pressure than required in the circuit. Shut valve (2).
- In tractor's cab, put hydraulic control lever on "Float position".
- Slightly open valve (2) so that oil slowly goes back to tractor.
- Once desired pressure is reached, close valve (2). Then hydraulic hose (1) may be disconnected.

7. DRIVING ON PUBLIC ROAD

Follow recommendations given in the safety section of this manual. They are not restrictive.

Before driving on a public road :

- **Be sure all signs, reflectors and lights required by local current law are in place, clean and visible to traffic.**
- **Make sure top link is in fixed hitching hole.**
- Make sure there are no interferences between tractor and machine.
- Adopt a gentle attitude towards other public road users.

On public road, comply with local applicable laws :

- Tractor required for road transport shall equal the size and the horse power rating of the tractor used to work in the field.
- Do not drive over 25 km/h (= 15 mph).
- Drive at a reasonable speed to maintain complete control of both tractor and machine.
- Reduce speed on corners and on rough grounds.
- Do not drive down a hill faster than it could be possible to drive it up.
- Do not apply the tractor brakes to attempt a sharp turn.
- Always check wheel studs tightness before driving on a public road. They may get loose because of vibrations.
- Respect authorized maximum size for transport load (width, weight, length). For over sized loads, comply with current law taking all necessary precautions (signs, lights, escort, authorizations, ...).
- Respect the maximum wheel axle load and the maximum total driving load. Make sure front axle carries at least 20% of tractor's tare. Use front end weights if necessary.

ATTENTION : driving on public roads, operator is responsible for both tractor and equipment. He has to comply with current applicable law (getting in conformity with it and following its evolutions).

8. FIELD ADJUSTMENT

Follow recommendations given in the safety section of this manual. They are not restrictive.

8.1. USING HELIOS

To reach the best result, use machine at a reasonable speed, with a slight angle towards previous crop seeding line (15° to 30°). This will allow :

- To avoid excessive track compaction,
- To improve trash flow and repartition,
- To leave an aerated and levelled ground surface.

Always lift up machine before manoeuvring or turning on headlands.

Never attempt a sharp turn with the machine in the ground.

Reduce speed before manoeuvring or crossing obstacles (ditch, ridge, rocky spots, ...).

8.2. ADJUSTING THE MACHINE

8.2.1. Depth control and front to rear levelling

Machine equipped with gauge wheels and / or rear roller

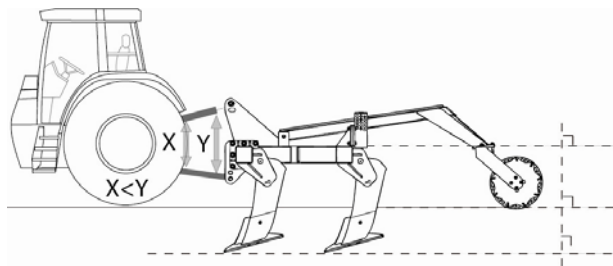

Top link shall be positioned in the slot.

To have a constant working depth, set tractor hydraulic lift on control position or on minimum draft control (10% to 20% max).

- **Working depth** is set by heights of both **tractor hydraulic lift** and **gauge wheels and / or rear roller** (refer to following sections).
- Working at desired depth, **machine main frame shall run level** (refer to picture).
- **Top link length** shall be adjusted so that working at desired depth **top link pin stays free to move** in the slot.

Machine without gauge wheels and / or rear roller

Top link shall be positioned in fixed hole.

To have a constant working depth, set tractor hydraulic lift on control position or on minimum draft control (10% to 20% max).

- **Working depth** is set by height of **tractor hydraulic lift**.
- **Top link length** shall be adjusted so that working at desired depth **machine main frame runs level**.

Note: when machine works at desired depth, take a few meters back to check its good levelling.

8.2.2. Weight transfer

Top link shall always be positioned higher on machine side than on tractor side. This will allow a good weight transfer on front axle. Refer to picture, $X < Y$.

8.2.3. Side to side levelling

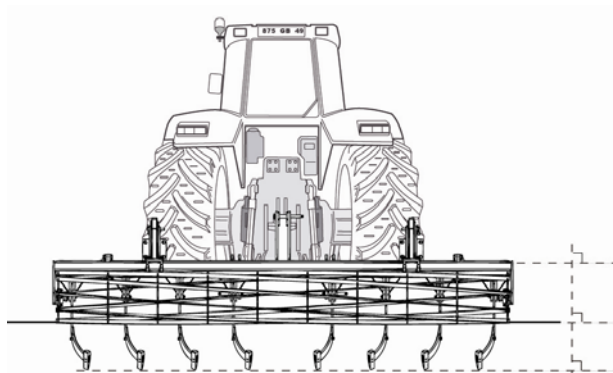

In working conditions, machine shall run level side to side (= from left to right), main frame strictly parallel to the ground.

It happens most of the time when tractor's preparation has been correctly done (same tyre pressure on both sides, tractor hitch levelled, stabilization system positioned ...).

Note: when machine works at desired depth, take a few meters back to check its good levelling.

8.3. MACHINE EQUIPPED WITH GAUGE WHEELS (OPTION)

Optional gauge wheels improve machine stability in the field and control working depth.

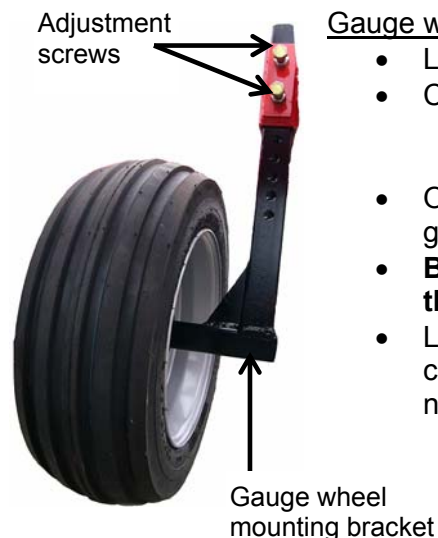

Gauge wheels height adjustment procedure

- Loose jam nut and adjustment screws.
- Change gauge wheels position :
 - ⇒ raise them to work deeper,
 - ⇒ lower them to work shallower.
- Once desired position is reached, tight adjustment screws in gauge wheel mounting bracket notches, then tight jam nuts.
- **Both gauge wheels mounting brackets shall be adjusted the same** for machine to work level side to side.
- Lower the machine into the ground, work a few meters and check performance of the new adjustment. Do it again if necessary.

8.4. MACHINE EQUIPPED WITH REAR ROLLER (OPTION)

The two sections foldable rear roller stabilizes the machine in the field and controls working depth. It might also have an action on the surface (levelling, mixing, ...) depending on its profile.

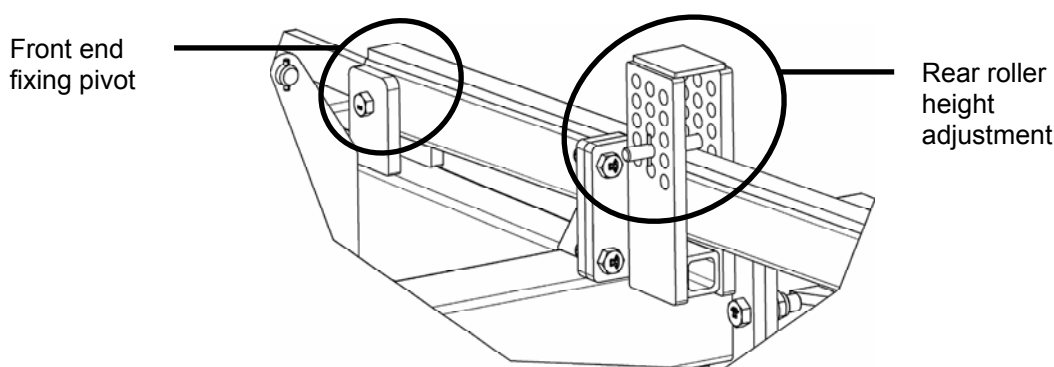

Both parts of the roller are attached to the machine with two arms. Each arm has a front end fixing pivot and a height adjustment mounting bracket (refer to picture).

Rear roller height adjustment procedure

- Remove safety clip and adjustment pin.
- Change pin position :
 - ⇒ put it higher into mounting bracket to increase working depth,
 - ⇒ put it lower into mounting bracket to decrease working depth,
- Put safety clip back,
- **Both mounting brackets shall be adjusted the same** for machine to work level side to side.
- Lower the machine into the ground, work a few meters and check performance of the new adjustment. Do it again if necessary.

9. MAINTENANCE

Follow recommendations given in the safety section of this manual. They are not restrictive.

9.1. GENERAL INSTRUCTIONS



Operator and user are responsible for good machine maintenance.



Inspect machine before and after each use. Repairs and service have to be done immediately so that they are not forgotten. Always leave the machine in a good state.

Cleaning the machine facilitates inspection. Check general state of machine, weldings, wheels studs, tyres, ...

Be careful with hydraulic lines : frictions may lead to excessive wearing and lines may leak. Never search a leak with your hands. Immediately replace any defective component. Spare components shall have the same characteristics.

Parts working in the ground may be sharpened and cause severe injury. Take particular care and use heavy leather gloves to remove them.

Never attempt any intervention on the machine while tractor engine is running.

Always properly secure all components before starting any maintenance operation underneath the machine.

Before using the machine for the first time, check all bolts tightness. Verify after 50 working hours and then at the beginning of each season. Pay special daily attention on :

- wheel studs tightness
- wearing parts bolts and nuts tightness in rocky or dry conditions (lots of vibrations).

9.2. SPARE PARTS

Genuine GREGOIRE-BESSON parts have been specially designed and developed. Only the use of these parts will ensure proper fit, longevity and field quality work of your machine.



Using any other spare part than certified from GREGOIRE-BESSON will void warranty.

Changing wearing parts too late may be cause of poor quality work (penetration troubles, ...) and may damage structure parts.

9.3. CHANGING WEARING PARTS

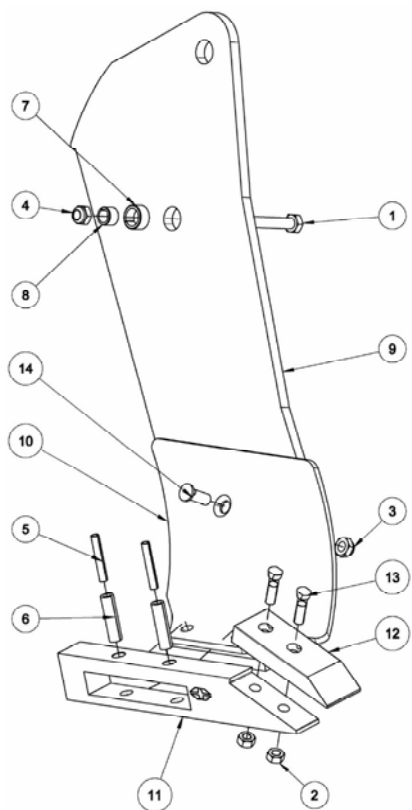

Change wearing parts (point and counter blade) before they do not protect structure parts any more (point support and blade).

- | | |
|------------------------------------|----------|
| 1. Shearing bolt H M14x80 - 8.8 Z | M211416 |
| 2. Std nut H M12 thread 1.75 | M241012 |
| 3. Nyloc nut std H M14 thread 1.50 | M242014 |
| 4. Nyloc nut std H M14 thread 1.50 | M242014 |
| 5. Roll pin 10 x 60 mm | M252012 |
| 6. Roll pin 16 x 60 mm | M252030 |
| 7. Shearing bushing Ø 16 mm | M260065 |
| 8. Shearing bushing Ø 22.5 mm | M260066 |
| 9. Heliplow tine twisted R.H. | M302048 |
| | L.H. |
| 10. Heliplow counter blade R.H. | M310064 |
| | L.H. |
| 11. Heliplow point support only | M320117 |
| 12. Heliplow bolted point standard | M320118 |
| 13. Conical head screw M12 x 59 | SP13559 |
| 14. T F screw M 14 x 40 - 8.8 | WM211408 |

Reversible share M320113

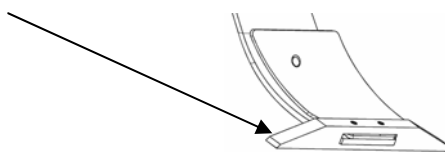

9.4. LUBRICATION

A good lubrication of all moving parts will both allow the machine to work fine and insure its long-lasting.

Grease fittings are installed on all pivot points. Grease both lubricates moving parts and chases away any abrasive dust that could come into pivot points.

Use quality grease, type Unil – Opal MS02 or equivalent.

Always wipe grease fittings with a clean rag before introducing grease. Do not hesitate to change any worn or broken grease fitting. Check for good grease course.

Remove all grease accumulation around grease fittings or moving parts.

Grease frequency recommendations are based on a regular use of the machine. Harder conditions would require more.

The best is to grease regularly with regular quantity. Do not over grease.

Grease fittings position	Grease frequency
Safety cylinders (1 grease fitting on each end)*	20 h
Tine articulations (2 grease fittings)*	20 h
Gauge wheels*	100 h
Rear roller bearings*	20 h

* Only for machines equipped with NSH safety device or optional attachments

9.5. ADDING OR REMOVING LATERAL EXTENSIONS

Lateral extensions have to be added or removed by pair : left hand side and right hand side.



Adding or removing lateral extensions requires specific equipments to support the machine and a chain lock to lift up parts.

Operator shall wear appropriate equipments such as helmet, protection glasses, heavy leather gloves, safety shoes ...



Machine shall be correctly hooked up to tractor to do this job.

Note : for machine equipped with a rear roller, adding extensions requires changing roller. The 3.20 m wide roller used on the 3.00 m frame will not cover the full working width of a 4.00 m frame.

Do not hesitate to contact an authorized Grégoire-Besson dealer to do this job.

Adding lateral extension procedure :

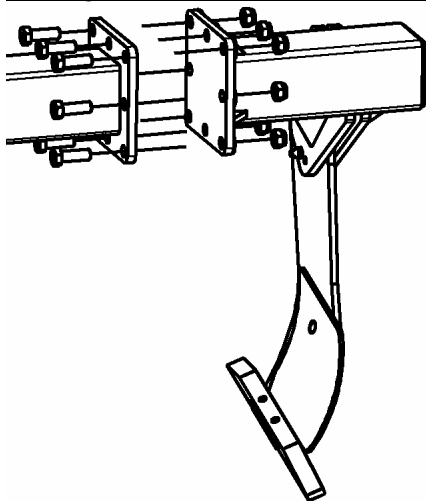

1. Park tractor and machine on a flat and firm surface.
2. Lower the machine, but leave a 15 cm clearance between ground and points.
3. Shut off tractor engine, set parking brakes and remove ignition key.
4. Approach lateral extension with a chain lock. Tight the 8 carriage bolts.
5. Detach chain lock.
6. for machine with NSH safety device :
 - ⇒ Open closing valve and remove all pressure.
 - ⇒ Connect both lateral extensions hoses to main hydraulic circuit.
 - ⇒ Put pressure back into circuit.

Check all bolts tightness after the first hours of use.

To remove lateral extensions, follow here above procedure the opposite way.



IMPORTANT : after removing lateral extensions take particular care on their storage. Crushing may lead to death.

Parts working in the ground may be sharpened and cause severe injury.

In case of any trouble, contact an authorized Grégoire-Besson dealer.

NOTES

10. QUICKLY STARTING HELIOS

**Be careful. Take all precautionary measures.
Respect safety recommendations.**

PREPARING THE TRACTOR

- 1. Check tyre pressure**
It should be the same on both sides on each axle.
Make sure all wheel studs are tight.
Always follow tyre manufacturer recommendations.
- 2. Adjust tractor hitch levelling**
Set lift links length for tractor hitch to be perfectly level with the ground.
Use a strict bar to verify lift links length alignment with the ground and / or rear axle.
- 3. Adjust lift links lateral sway**
Set stabilizers to let a minimum lateral sway (2 to 4 cm).
- 4. Check top link**
Connexion between top link and machine must be done through a tie rod and not through an automatic hook.

HITCHING

- 5. Attach lower links**
- 6. Attach top link**
In fixed hole = transport position / working position for machine without gauge wheels or rear roller.
In slot = working position for machine equipped with gauge wheels or rear roller.
- 7. Make sure there are no interferences between machine and tractor from raised position to working position**
Machine shall never come in contact with tractor.
There should be no contact between tractor lift links and machine yoke hitch.

FIELD AJUSTMENT

- 8. In working conditions, at desired depth, frame shall run level**
Side to side levelling.
Front to rear levelling.
- 9. Verify that there are no frictions in machine yokes hitch**
- 10. In tractor's cab,**
Put hydraulic lift on control of position or on minimum draft control.
- 11. Using the machine with gauge wheels or rear roller**
Set gauge wheels and / or rear roller height so that machine works level at desired depth

MAINTENANCE

- 12. Follow recommendations given in this manual according to lubrication and maintenance of the machine**

NOTES

GRÉGOIRE  **BESSON**

**49230 MONTFAUCON-MONTIGNÉ-SUR-MOINE
FRANCE**

**TÉL. (+33) (0)2 41 64 72 67
FAX (+33) (0)2 41 64 67 73**

GRÉGOIRE-BESSON UK

Bourne Road, Carlby - STAMFORD Lincs PE9 4 NG – ENGLAND
phone (44) 01 778 590 223 - Fax (44) 01 778 590 645

GRÉGOIRE-BESSON CANADA INC

4480, Rue Martineau - ST-HYACINTHE (P. Québec) - CANADA J2R 1V1
TÉL. (1) 450 799 56 15 - FAX (1) 450 799 56 29

GRÉGOIRE-BESSON POLSKA

Ruda 12 - PL - 64610 ROGOZNO – TÉL / FAX (48) (67) 261 97 79

ООО «ГРЕГУАР-БЕССОН ВОСТОК»

Россия 308006 г. Белгород,
ул. Корочанская, 132а
Тел/факс: +7(4722) 58 70 36, 58 70 35
E-mail: info@gbvostok.ru
www.gregoire-besson.com

法国格力格尔 - 贝松公司北京代表处
北京市朝阳区延静里中街3号长信大厦220室
邮编：100025

WEB : www.gregoire-besson.fr **E.MAIL** : Contactfr@gregoirebesson.fr