

GRÉGOIRE  **BESSON**

HELIPLow BIPOUTRE

Subsoiler twin beam fully mounted fixed

OPERATOR'S MANUAL MAINTENANCE INSTRUCTIONS



GRÉGOIRE-BESSON S.A.

Rue Victor Grégoire
49 230 MONTFAUCON – MONTIGNÉ
France

Tél. : 33 (0) 2 41 64 72 67
Fax : 33 (0) 2 41 64 67 73

Web : www.gregoire-besson.com
Email : Contactfr@gregoirebesson.com

November 2008

TABLE OF CONTENTS

1. INTRODUCTION	2
2. SAFETY INSTRUCTIONS	3
2.1. SAFETY STICKERS	3
2.2. SAFETY WHILE ATTACHING AND DETACHING	5
2.3. SAFETY WHILE CONNECTING HYDRAULIC LINES	5
2.4. SAFETY WHILE OPERATING MACHINE	5
2.5. SAFETY FOR MAINTENANCE	6
2.6. SAFETY FOR ON HIGHWAY TRANSPORT	6
3. MACHINE DESCRIPTION	7
3.1. IDENTIFICATION VIEWS	7
3.2. « MICHEL » TINE	7
3.3. TECHNICAL SPECIFICATIONS	8
3.4. DIMENSIONS AND WEIGHTS	8
4. PREPARING THE TRACTOR	9
4.1. REQUIRED HORSE POWER	9
4.2. TRACTOR WHEELS	9
<u>4.2.1. Distance between tractor tyres</u>	9
<u>4.2.2. Tractor tyres</u>	9
4.3. FRONT END WEIGHTING	9
4.4. POSITIONING STABILIZERS	10
4.5. LIFT LINKS LENGTH	10
4.6. TOP LINK	10
5. ATTACHING AND DETACHING	11
5.1. ATTACHING MACHINE TO TRACTOR	11
<u>5.1.1. Tractor equipped with tie rods lower links</u>	11
<u>5.1.2. Tractor equipped with automatic hooks lower links</u>	11
<u>5.1.3. Hitching top link</u>	12
5.2. DETACHING THE MACHINE	12
6. TRANSPORTING	13
6.1. CHANGING TO TRANSPORT POSITION	13
6.2. DRIVING ON PUBLIC ROAD	13
7. FIELD ADJUSTMENT	14
7.1. MACHINE UTILISATION	14
7.2. ADJUSTING THE MACHINE	14
<u>7.2.1. Depth control and front to rear levelling</u>	14
<u>7.2.2. Weight transfer</u>	15
<u>7.2.3. Side to side levelling</u>	15
7.3. MACHINE EQUIPPED WITH REAR ROLLER (OPTION)	15
8. MAINTENANCE	22
8.1. GENERAL INSTRUCTIONS	22
8.2. SPARE PARTS	22

Any use and / or reproduction of all or part of this manual without written authorization from Grégoire-Besson is strictly prohibited.

1. INTRODUCTION



READ CAREFULLY THIS MANUAL



To properly start, operate and service your equipment, follow all instructions given in this manual.

THIS MANUAL SHOULD BE CONSIDERED AS A PART OF THE EQUIPMENT AND SHOULD FOLLOW IT WHEN YOU SELL IT.

LEFT HAND SIDE AND RIGHT HAND SIDE, FRONT AND REAR are determined looking from equipment towards tractor when in work.

ALL INFORMATIONS, PICTURE, SPECIFICATIONS in this manual are based on the newer information available at the time of publication. Pictures and drawings might not represent standard equipment and show optional attachments.

Manufacturer reserves right to make any changes at all time **without any obligation to notice or to modify any delivered or already sold machine.**

If the machine has been modified in any way from the original design without written agreement from GREGOIRE-BESSON, the manufacturer does not accept any liability for injury or warranty. Warranty would become void.



This symbol is used in the following manual to **catch your attention on warnings concerning your safety.**

So please when you see it in this manual or on the equipment, **strictly follow given information.**

GREGOIRE-BESSON equipments are exclusively designed to be used for regular farm tillage in farmed fields. Manufacturer shall not be responsible for damage or injury resulting from any other use.

PRODUCT IDENTIFICATION NUMBER

Please record here purchasing date, model and serial number of your equipment (refer to identification plate on hitch). Always refer to these information to get prompt and good service.

Purchasing date :

Model :

Serial number :

Salesman's phone :

2. SAFETY INSTRUCTIONS

2.1. SAFETY STICKERS



READ OPERATOR'S MANUAL

Read operator 's manual and safety instructions before starting the use of your equipment and follow them while using.



Reference : UI 129



UNFOLDING AREA

Stay clear of equipment when folding or unfolding.

Reference : UI 126



MOVE AWAY FROM THE MACHINE

Danger in the working area, stay clear from the machine.

Reference : UI 127

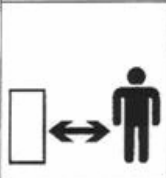

SECURE THE MACHINE BEFORE ACTION

Always install all lockup devices to secure machine before any intervention on it.

Reference : UI 131



HYDRAULIC LEAK AND MAINTENANCE

Caution, high pressure fluids can cause injury. Follow safe practices.

Reference : UI 128



Positioning safety stickers on the machine

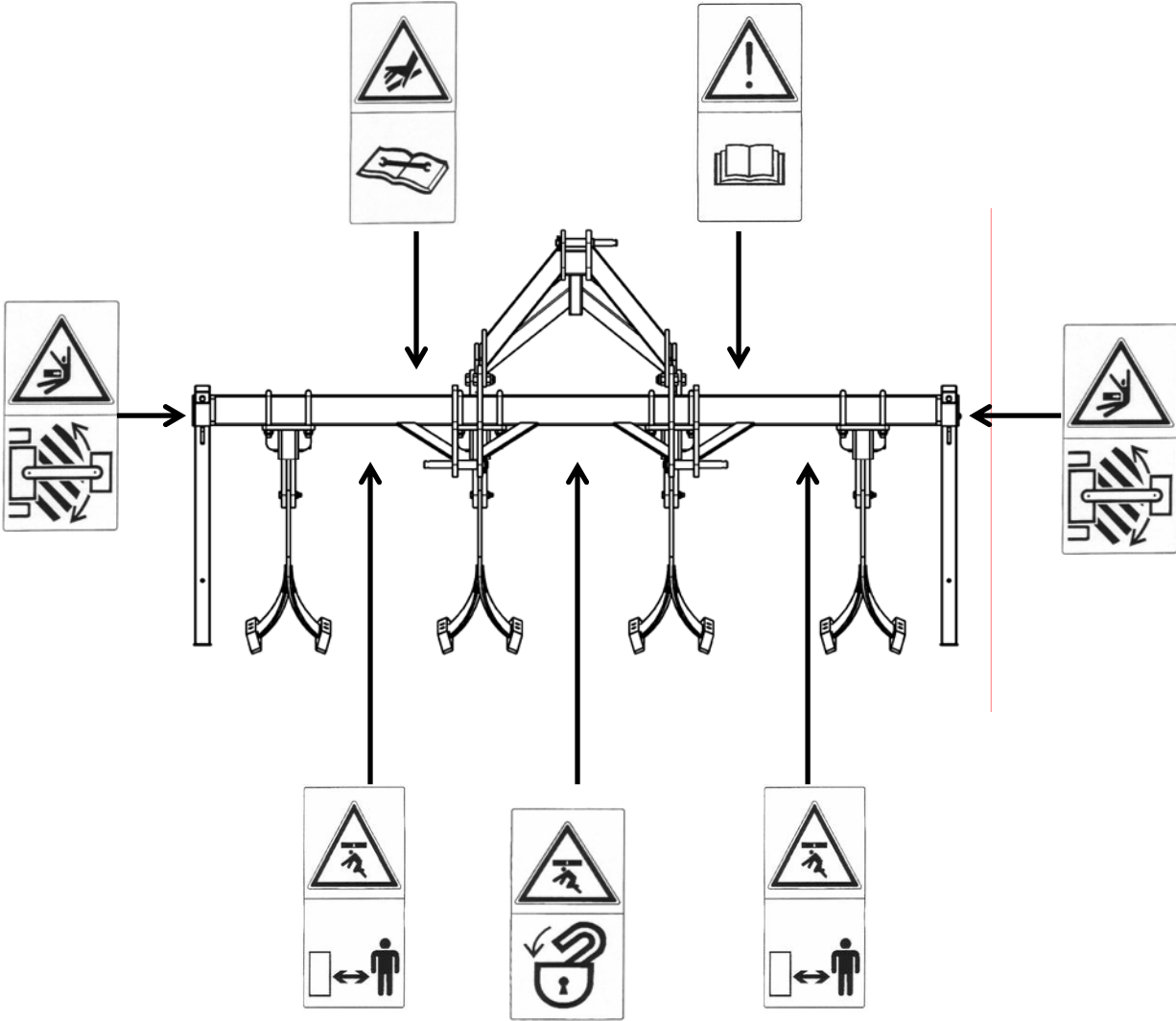

2.2. SAFETY WHILE ATTACHING AND DETACHING



- Do not let **anyone to stand between the machine and the tractor** when you back up to hitch.
- Before leaving the tractor to hitch or unhitch, set tractor parking brakes.
- Do not try to hitch the machine if you do not have the right size pins (diameter and length shall be compatible between both tractor and machine).
- Completely lower the machine to the ground before unhitching. Make sure it is on a level and firm surface.
- Remove pressure from hydraulic lines before disconnecting them.
- Before leaving the machine for storage, make sure it is in a safe place and that there is no risk to damage whether anything or anyone.

2.3. SAFETY WHILE CONNECTING HYDRAULIC LINES



- Hydraulic circuit might be highly pressurised.
- **Never use your hands to locate a hydraulic leak.** Hydraulic fluids escaping under pressure have sufficient force to penetrate the skin, causing severe injury. In case of any injury, **see a doctor immediately.**
- For equipments loaded with several hydraulic connectors, **make logical and appropriated connections.**
- Before connecting hydraulic circuit, **make sure that there is no pressure on both sides (tractor and machine).**
- Regularly check hydraulic lines and connections. **Replace any damaged or leaking component** by an original part with the same specifications.
- Before any intervention on hydraulic circuit, **lower machine to the ground and release pressure moving control lever in the tractor's cab.**

2.4. SAFETY WHILE OPERATING MACHINE

- **Never attempt** any intervention on the machine while it is in motion.
- Wear close **fitting clothing** and **appropriate safety devices** for the job you have to do (heavy leather gloves, safety shoes, earplugs, ...).
- Do not allow anyone to stand close to the machine.
- Do not attempt to do any adjustment if you have not perfectly understood its procedure.
- Always use tools or equipments appropriate to the job you are doing. All GREGOIRE-BESSON equipments are metric standards.
- Learn how to operate your machine and how to use its controls. Do not let anyone operate without instruction.
- Only one person (the operator) should be in the tractor's cab when it is in operation. **No one on the machine while working or travelling on the road.**



If your machine is equipped with a hydraulic folding mechanism, **always use it from tractor's cab, once you are sure that folding area is free from spectators or obstacles.**

2.5. SAFETY FOR MAINTENANCE



During maintenance operation, comply with the following rules

- Maintenance area shall be **clean, dry, with enough light and ventilation.**
- For any intervention on the machine in raised position, **always securely support all components** before starting maintenance.
- After servicing remove all tools, components and parts you used.
- Regularly check tightness of wheel studs, tine bottom studs, and other bolts and nuts.
- **Always use genuine parts corresponding to manufacturer's technical specification requirements.**

2.6. SAFETY FOR ON HIGHWAY TRANSPORT



FOR YOUR OWN SAFETY AND THE ONE OF THE OTHER, RESPECT THE FOLLOWING RULES :

- All GREGOIRE-BESSON equipments shall be used **complying with area's current rules and laws** concerning **safety instructions, accident prevention** and **provision of Highway Code.**
- Always **check for wheels studs tightness before road transport.**
- **Use all devices required by your area's current laws** (lights, reflectors, signs, ...). You might remove them in during field operation to prevent from any damage. It is the operator's responsibility to comply with current law and to follow its evolutions.
- Regularly check hitching pins, change them if necessary. Tractor's ball joint may also wear, do not hesitate to replace them with new ones having at least Waltersheid fabrication quality.
- Drive **at reasonable speed** complying with local laws **to always keep control** of tractor and equipment. Pay special attention on irregular or rough roads. **Do not attempt to drive down a hill faster than it could be possible to drive it up.**
- **Never attempt any manoeuvre if area is not free from spectators.**
- If your machine is equipped with a **folding mechanism** (manual or hydraulic), **use it making sure folding area is free from spectators** and obstacles.
- Follow all **safe driving practices** when travelling, moreover **on corners, rough or narrow roads.**
- When **leaving tractor** even for a short period, **shut off engine, remove ignition key** and **set parking brakes.**
- Forbid anyone to stand between tractor and machine or on the machine travelling on the road.

3. MACHINE DESCRIPTION

3.1. IDENTIFICATION VIEWS

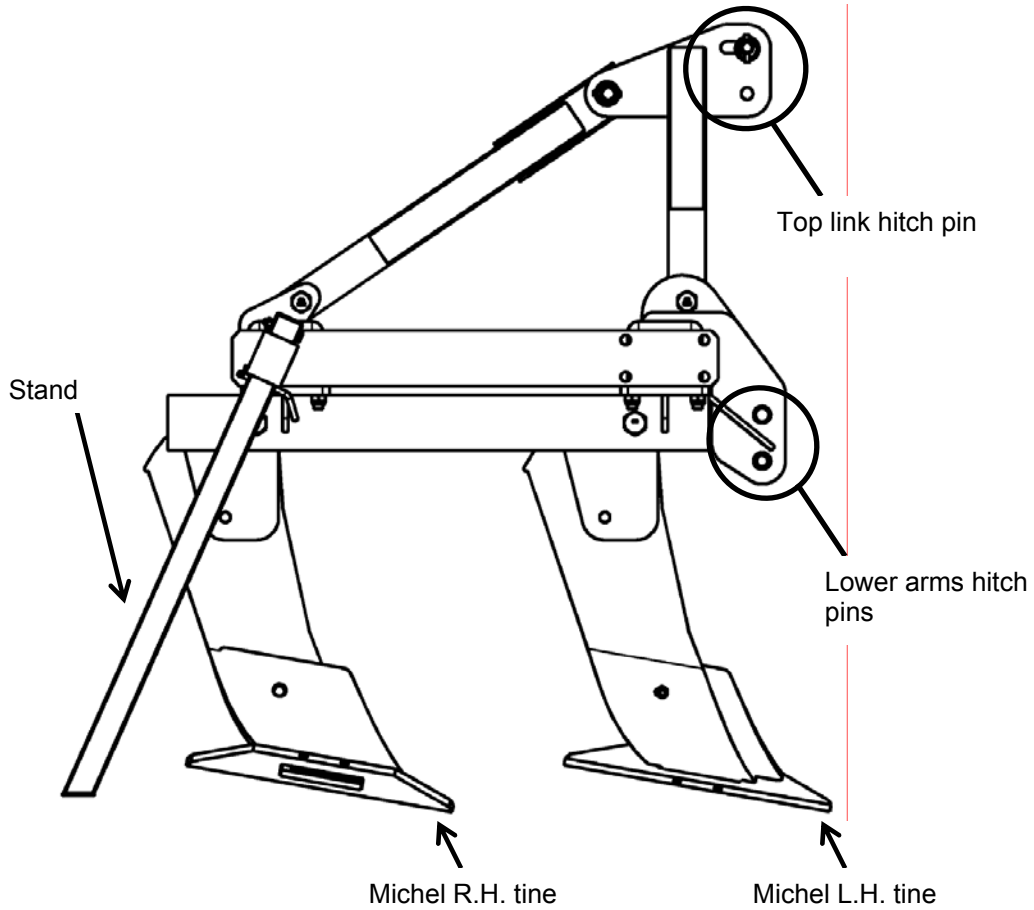

3.2. « MICHEL » TINE

Shear bolt safety device

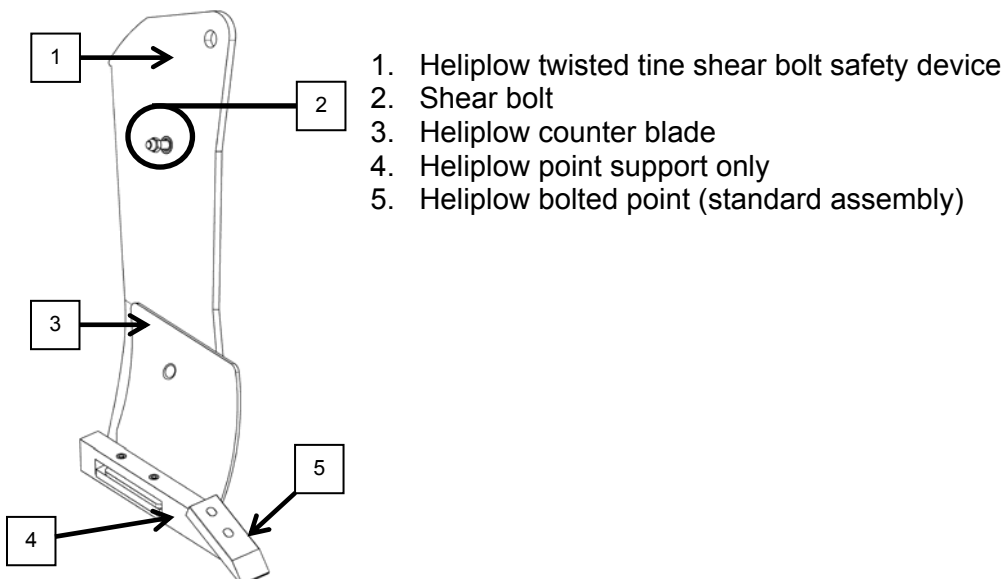

3.3. TECHNICAL SPECIFICATIONS

Specification	Standard equipments	Optional equipments
Front 3 point linkage	<ul style="list-style-type: none"> In yoke Ø II et III, width 2 on 2.4 m and 3.2 m; width 3 on 4.0 m 	
Frame	<ul style="list-style-type: none"> Twin beam main frame section 120 x 120 mm Parking stands 	<ul style="list-style-type: none"> Pair of gauge wheels tyres 10/75-12 or 10/75-15
Clearance between beams	<ul style="list-style-type: none"> 700 mm 	
Underbeam clearance	<ul style="list-style-type: none"> 850 mm 	
Working tines	<ul style="list-style-type: none"> Curved tines type « Michel » in special treated steel Bolted point on tilted support 	<ul style="list-style-type: none"> Reversible share
Safety device	<ul style="list-style-type: none"> Shear bolt 	
Rear accessories		<ul style="list-style-type: none"> Rear roller

A large choice of options is available to improve machine's job. Grégoire-Besson authorized dealers know area and working conditions. They may give information according to technical choices and latest equipments evolutions. Grégoire-Besson is also represented on farm equipment shows.

3.4. DIMENSIONS AND WEIGHTS

Nb of blades	Working width	Transport Width	Indicative weight - shear bolt SD
6	2.40 m	2.40 m	800 kg
8	3.20 m	3.20 m	1 160 kg
12	4.00 m	4.00 m	1 600 kg

Dimensions and weights are indicative and subject to variations according to equipments and options.

NOTE : after use, ground or residue accumulations may increase machine's weight.

4. PREPARING THE TRACTOR

Follow recommendations given in the safety section of this manual. They are not restrictive.

4.1. REQUIRED HORSE POWER

Tractor requirements may vary according to ground and working conditions (type of soil, type of tractor, type of tyres, ...). Following data are only indicative. Ask an authorized Grégoire-Besson dealer for any further information.

Number of tines	Working width	Required HP (average)
6	2.40 m	100 / 120 HP
8	3.20 m	140 / 160 HP
10	4.00 m	180 / 200 HP

4.2. TRACTOR WHEELS

4.2.1. Tractor tyres

Check tractor tyres general state and pressure. Pressure should be the same on both sides of the tractor for a nice drivability in the field and on the road.



IMPORTANT : inflate tyres following manufacturer's recommendations.

4.2.2. Distance between tractor tyres

Generally, using a large tillage equipment, the wider is the distance between tyres, the better is the drivability.

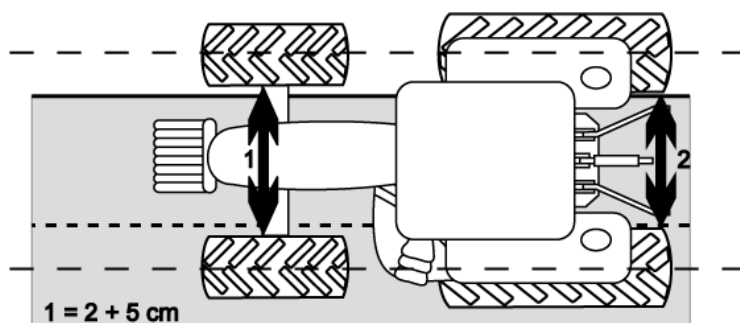

To be able to steer the tractor, the middle of the front axle shall be lined up with the middle of the rear axle.

In sloping fields, a large distance will provide good stability.

4.3. FRONT END WEIGHTING

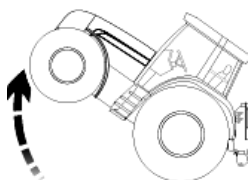

Wheels weights (front and rear) and front end weights may be required to avoid excessive slippage and to increase stability in rough and sloppy grounds.

Weights shall not be added once all slippage is eliminated. Refer to tractor operator's manual and to tractor's dealer. Follow tyre manufacturer's recommendations.

4.3. POSITIONING STABILIZERS

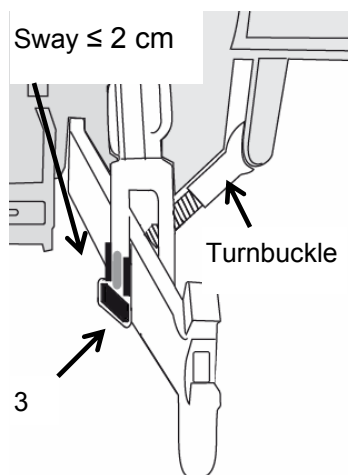

To hitch any tillage equipment on lower link arms, stabilizers shall be set so that arms have minimum lateral sway (≤ 2 cm) and are centred with tractor traction line. This will both prevent from any risk of shock during manoeuvre or road transport and keep machine lined up behind tractor at work.

Note : it is easier to adjust and / or service stabilisers bolts and threads before hitching the machine.

Horizontal lift links pins (3) shall be in fixed position to avoid any loose and / or damageable shock.

4.4. LIFT LINKS LENGTH

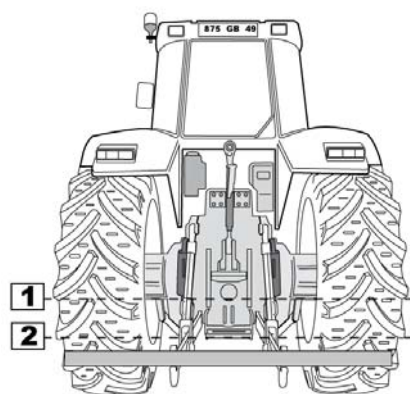

Lift link arms length determines tractor hitch levelling and lift cylinder position at working depth.

- Set lift links length so that tractor hitch is level (refer to picture).
- Set lift links length to have at least 30 mm clearance on lift cylinder rod when machine is working at desired depth. This will give adjustment possibilities for front gang depth from tractor's cab and allow efficient tractor draft control

4.6. TOP LINK

Before attaching the machine, make sure that thread length is the same on both sides of top link. Refer to picture, A shall equal B.

Top link length will be adjusted in the field.

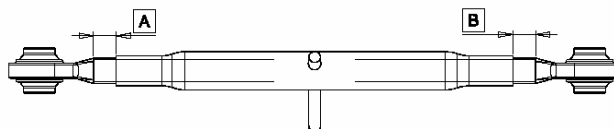

IMPORTANT : connection between machine and top link shall be done through a tie rod and never through an automatic hook.

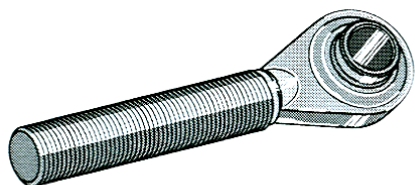

Example of tie rod
CORRECT

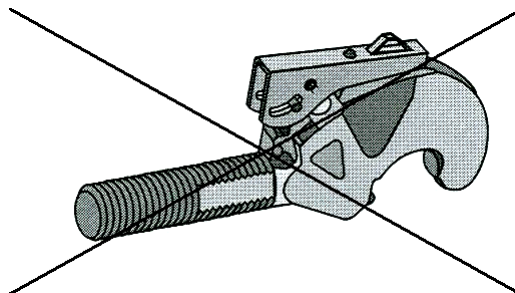

Example of automatic hook
DO NOT USE

Do not hesitate to contact an authorized Grégoire-Besson dealer for any further information.

5. ATTACHING AND DETACHING

Follow recommendations given in the safety section of this manual. They are not restrictive.

IMPORTANT : never attempt to attach the machine if pins or tractor hitching balls are worn or not compatible.

5.1. ATTACHING MACHINE TO TRACTOR

5.1.1. Tractor equipped with tie rods lower links

- Before any manoeuvre, check for diameter and length compatibility between hitch pins and tractor tie rods.
- Remove safety pins clips and hitch pins.
- Back up tractor to line up tie rods and machine hitch holes. Always first try to hitch machine as low as possible. In a second time, according to conditions (lift links length, wheels diameter, ...) other possibilities may be tried.
- Install pins and secure them with their safety clips.
- If holes are difficult to line up : extend telescopic arms as indicated in tractor operator's manual. Once hitch pins are inserted and secured with their safety clips, slowly back up tractor to lock back lift arms. Check for lift arms locking.
- Hitch top link.

5.1.2. Tractor equipped with automatic hooks lower links

- Remove safety clips and hitch pins.
- Remove balls from tractor lift link automatic hooks.
- Check for balls and pins general state and compatibility.
- Install balls on pins through lower machine hitching holes. Secure with safety clips.
- Slowly back up tractor till automatic hooks are lined up underneath hitch balls.
- Raise tractor hitch about 5 cm above ground surface till automatic hooks are locked.
- Check for automatic hooks latch handles good locking.
- Hitch top link.



IMPORTANT : before hitching top link, **make sure to have enough clearance between machine yoke hitch and tractor lower lift links to avoid any possibility of contact from working to raised position.**

5.1.3. Hitching top link

Connexion between top link and machine has to be done through a tie rod (refer to previous section).

Once tractor lift links are correctly hooked up, check top link general state and compatibility with tie rod. Then attach top link in one of the two holes : **fixed hole for road transport**, or **slot for field operation** using gauge wheels or rear roller.

Raise machine to the maximum and make sure there are no interference with tractor. Final top link adjustments (length and position) will be made in the field.



IMPORTANT : make sure to have enough clearance between machine yoke hitch and top link to avoid any contact from working to raised position.

5.2. DETACHING THE MACHINE

Before detaching, make sure that ground is flat and firm enough to support the machine. Use safety blocks to support machine components if necessary.



DANGER : do not let any part of your body underneath the machine when lowering it to the ground.

Crushing may lead to death.

Proceed in the logical attaching opposite way :

- 1) Completely lower the machine to the ground,
- 2) Detach top link
- 3) Detach lower lift links

Always operate with care.

6. TRANSPORTING

Follow recommendations given in the safety section of this manual. They are not restrictive.

6.1. CHANGING TO TRANSPORT POSITION

Before driving on a public road with machine, put top link pin in the upper fixed hole. Secure it with its safety clip.

- Raise machine to the maximum.
- Block hydraulic control levers in tractor to avoid any unforeseen movement.

6.2. DRIVING ON PUBLIC ROAD

Before driving on a public road :

- **Be sure all signs, reflectors and lights required by local current law are in place, clean and visible to traffic.**
- Make sure there are no interferences between tractor and machine.
- Adopt a gentle attitude towards other public road users.

On public road, comply with local applicable laws :

- Tractor required for road transport shall equal the size and the horse power rating of the tractor used to work in the field.
- Do not drive over 25 km/h (= 15 mph).
- Drive at a reasonable speed to maintain complete control of both tractor and machine.
- Reduce speed on corners and on rough grounds.
- Do not drive down a hill faster than it could be possible to drive it up.
- Do not apply the tractor brakes to attempt a sharp turn.
- Always check wheel studs tightness before driving on a public road. They may get loose because of vibrations.
- Respect authorized maximum size for transport load (width, weight, length). For over sized loads, comply with current law taking all necessary precautions (signs, lights, escort, authorizations, ...).
- Respect the maximum wheel axle load and the maximum total driving load. Make sure front axle carries at least 20% of tractor's tare. Use front end weights if necessary.

ATTENTION : driving on public roads, operator is responsible for both tractor and equipment. He has to comply with current applicable law (getting in conformity with it and following its evolutions).

7. FIELD ADJUSTMENT

Follow recommendations given in the safety section of this manual. They are not restrictive.

7.1. MACHINE UTILISATION

Put machine in working position. **Do not forget to remove transport position safety turnbuckle before unfolding the machine.**

Once machine is unfolded, put tractor hydraulic control lever on "Neutral position".

To reach the best result, use machine at a reasonable speed, with a slight angle towards previous crop seeding line (15° to 30°). This will allow :

- To avoid excessive track compaction,
- To improve trash flow and repartition,
- To leave an aerated and levelled ground surface.

Always lift up machine before manoeuvring or turning on headlands.

Never attempt a sharp turn with the machine in the ground.

Reduce speed before manoeuvring or crossing obstacles (ditch, ridge, rocky spots, ...).

7.2. ADJUSTING THE MACHINE

7.2.1. Depth control and front to rear levelling

Machine without gauge wheels and / or rear roller

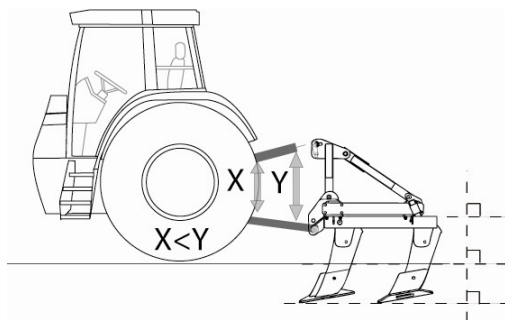

Top link shall be positioned in fixed hole.

To have a constant working depth, set tractor hydraulic lift on control position or on minimum draft control (10% to 20% max).

- **Working depth** is set by height of **tractor hydraulic lift**.
- **Top link length** shall be adjusted so that working at desired depth **machine main frame runs level**.

Machine equipped with gauge wheels and / or rear roller

Top link shall be positioned in the slot.

To have a constant working depth, set tractor hydraulic lift on control position or on minimum draft control (10% to 20% max).

- **Working depth** is set by heights of both **tractor hydraulic lift** and **gauge wheels and / or rear roller** (refer to following sections).
- Working at desired depth, **machine main frame shall run level** (refer to picture).
- **Top link length** shall be adjusted so that working at desired depth **top link pin stays free to move** in the slot.

NOTE : when machine works at desired depth, take a few meters back to check its good levelling.

7.2.2. Weight transfer

Top link shall always be positioned higher on machine side than on tractor side. This will allow a good weight transfer on front axle. Refer to picture, $X < Y$.

7.2.3. Side to side levelling

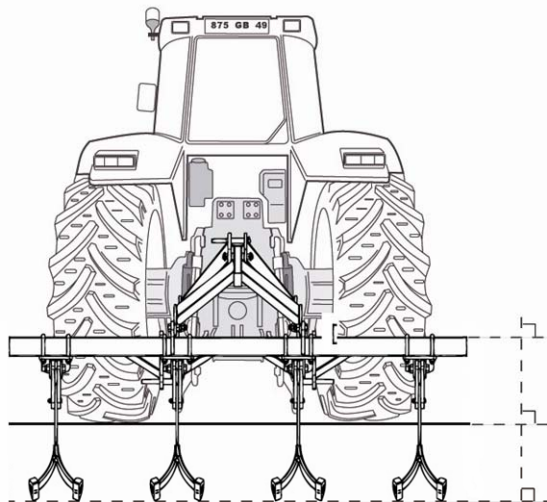

In working conditions, machine shall run level side to side (= from left to right), main frame strictly parallel to the ground.

It happens most of the time when tractor's preparation has been correctly done (same tyre pressure on both sides, tractor hitch levelled, stabilization system positioned ...).

NOTE: when machine works at desired depth, take a few meters back to check its good levelling.

7.3. MACHINE EQUIPPED WITH REAR ROLLER (OPTION)

The two sections foldable rear roller stabilizes the machine in the field and controls working depth. It might also have an action on the surface (levelling, mixing, ...) depending on its profile.

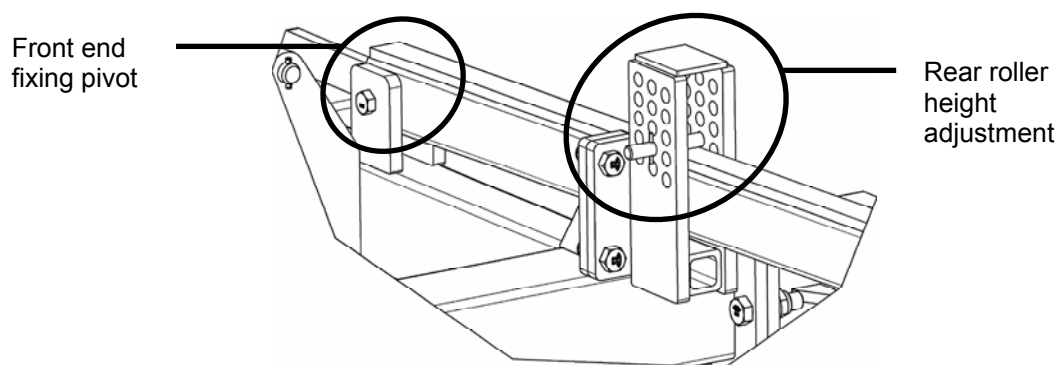

Both parts of the roller are attached to the machine with two arms. Each arm has a front end fixing pivot and a height adjustment mounting bracket (refer to picture).

Rear roller height adjustment procedure

- Remove safety clip and adjustment pin.
- Change pin position :
 - ⇒ put it higher into mounting bracket to increase working depth,
 - ⇒ put it lower into mounting bracket to decrease working depth,
- Put safety clip back,
- **All four mounting brackets shall be adjusted the same** for machine to work level side to side.
- Lower the machine into the ground, work a few meters and check performance of the new adjustment. Do it again if necessary.

8. MAINTENANCE

Follow recommendations given in the safety section of this manual. They are not restrictive.

8.1. GENERAL INSTRUCTIONS



Operator and user are responsible for good machine maintenance.



Inspect machine before and after each use. Repairs and service have to be done immediately so that they are not forgotten. Always leave the machine in a good state.

Cleaning the machine facilitates inspection. Check general state of machine, weldings, wheels studs, tyres, ...

Be careful with hydraulic lines : frictions may lead to excessive wearing and lines may leak. Never search a leak with your hands. Immediately replace any defective component. Spare components shall have the same characteristics.

Parts working in the ground may be sharpened and cause severe injury. Take particular care and use heavy leather gloves to remove them.

Never attempt any intervention on the machine while tractor engine is running.

Always properly secure all components before starting any maintenance operation underneath the machine.

Before using the machine for the first time, check all bolts tightness. Verify after 50 working hours and then at the beginning of each season. Pay special daily attention on :

- wheel studs tightness
- wearing parts bolts and nuts tightness in rocky or dry conditions (lots of vibrations).

Wrong waste management is a danger for environment : collect waste oil, paint removers, accumulators, worn tyres ... Bring them back to a distributor or to an authorized collector. Do not let them in the nature.

8.2. SPARE PARTS

Genuine GREGOIRE-BESSON parts have been specially designed and developed. Only the use of these parts will ensure proper fit, longevity and field quality work of your machine.



Using any other spare part than certified from GREGOIRE-BESSON will void warranty.

Changing wearing parts too late may be cause of poor quality work (penetration troubles, ...) and may damage structure parts.

GRÉGOIRE  **BESSON**

**49230 MONTFAUCON-MONTIGNÉ-SUR-MOINE
FRANCE**

TÉL. (+33) (0)2 41 64 72 67

FAX (+33) (0)2 41 64 67 73

GRÉGOIRE-BESSON UK

Bourne Road, Carlby - STAMFORD Lincs PE9 4 NG – ENGLAND
phone (44) 01 778 590 223 - Fax (44) 01 778 590 645

GRÉGOIRE-BESSON CANADA INC

4480, Rue Martineau - ST-HYACINTHE (P. Québec) - CANADA J2R 1V1
TÉL. (1) 450 799 56 15 - FAX (1) 450 799 56 29

GRÉGOIRE-BESSON POLSKA

Ruda 12 - PL - 64610 ROGOZNO – TÉL / FAX (48) (67) 261 97 79

ООО «ГРЕГУАР-БЕССОН ВОСТОК»

Россия 308006 г. Белгород,
ул. Корочанская, 132а
Тел/факс: +7(4722) 58 70 36, 58 70 35
E-mail: info@gbvostok.ru
www.gregoire-besson.com

法国格力格尔 - 贝松公司北京代表处
北京市朝阳区延静里中街3号长信大厦220室
邮编：100025

WEB : www.gregoire-besson.fr **E.MAIL** : Contactfr@gregoirebesson.fr