

GRÉGOIRE  **BESSON**

PLANISPIRE

Fully mounted front implement

Spiral front packer

OPERATOR'S MANUAL MAINTENANCE INSTRUCTIONS



GRÉGOIRE-BESSON S.A.
Rue Victor Grégoire
49 230 MONTFAUCON – MONTIGNÉ
France

Phone : 33 (0) 2 41 64 72 67
Fax : 33 (0) 2 41 64 67 73

Web : www.gregoire-besson.com
Email : Contactfr@gregoirebesson.com

Original version
February 2010

TABLE OF CONTENTS

1. INTRODUCTION	4
PRODUCT IDENTIFICATION	4
2. SAFETY INSTRUCTIONS	5
2.1. SAFETY STICKERS	5
2.2. SAFETY WHILE ATTACHING AND DETACHING	7
2.3. SAFETY WHILE CONNECTING HYDRAULIC LINES	7
2.4. SAFETY WHILE OPERATING MACHINE	7
2.5. SAFETY FOR MAINTENANCE	8
2.6. SAFETY FOR ON HIGHWAY TRANSPORT	8
3. MACHINE DESCRIPTION	9
3.1. IDENTIFICATION VIEWS	9
3.2. TECHNICAL SPECIFICATIONS	10
3.3. DIMENSIONS AND WEIGHTS	10
3.4. SIGNS	10
3.5. TRIANGULATION	11
3.6. TWO ROWS OF STRAIGHT TINES (option)	11
4. PREPARING THE TRACTOR	12
4.1. REQUIRED HYDRAULIC FRONT LIFT CAPACITY	12
4.2. TRACTOR WHEELS	12
<u>4.2.1. Tractor tyres</u>	12
<u>4.2.2. Distance between tractor tyres</u>	12
4.3. TRACTOR EQUILIBRIUM	12
5. ATTACHING AND DETACHING	13
5.1. ATTACHING MACHINE TO TRACTOR	13
<u>5.1.1. Hitching lower links</u>	13
<u>5.1.2. Hitching top link</u>	13
5.2. DETACHING THE MACHINE	14
6. HYDRAULIC CONNEXIONS	15
6.1. REQUIRED HYDRAULIC REMOTES	15
6.2. HYDRAULIC CONNECTIONS	15
7. PREPARING THE MACHINE	16
7.1. ADJUSTING POINTS LOCALIZATION	16
7.2. ADVANCED FRONT PIVOT POINT	17
7.3. LEVELLING TINES HEIGHT ADJUSTMENT (option)	18

8. TRANSPORTING	19
8.1. CHANGING TO TRANSPORT POSITION	19
8.2. CHANGING TO WORKING POSITION	20
8.3. DRIVING ON PUBLIC ROAD	20
9. FIELD ADJSUTMENT	21
9.1. FIELD UTILIZATION	21
9.2. DEPTH CONTROL AND FRONT TO REAR LEVELLING	21
9.3. SIDE TO SIDE LEVELLING	22
9.4. IF GROUND IS NOT LEVELLED	22
10. MAINTENANCE	23
10.1. GENERAL INSTRUCTIONS	23
10.2. LUBRICATION	23
10.3. SPARE PARTS	24
10.4. STORAGE SAFETY	24
11. WEIGHT DISTRIBUTION	25
12. QUICKLY STARTING - PLANISPIRE	28

Any use and / or reproduction of all or part of this manual without written authorization from Grégoire-Besson is strictly prohibited.

NOTES

1. INTRODUCTION



READ CAREFULLY THIS MANUAL



To properly start, operate and service your equipment, follow all instructions given in this manual.

THIS MANUAL SHOULD BE CONSIDERED AS A PART OF THE EQUIPMENT AND SHOULD FOLLOW IT WHEN YOU SELL IT.

LEFT HAND SIDE AND RIGHT HAND SIDE, FRONT AND REAR are determined looking from equipment towards tractor when in work.

ALL INFORMATIONS, PICTURE, SPECIFICATIONS in this manual are based on the newer information available at the time of publication. Pictures and drawings might not represent standard equipment and show optional attachments.

Manufacturer reserves right to make any changes at all time **without any obligation to notice or to modify any delivered or already sold machine.**

If the machine has been modified in any way from the original design without written agreement from Grégoire-Besson, the manufacturer does not accept any liability for injury or warranty. Warranty would become void.



This symbol is used in the following manual to **catch your attention on warnings concerning your safety.**

So please when you see it in this manual or on the equipment, **strictly follow given information.**

Grégoire-Besson equipments are exclusively designed to be used by professionals for regular farm tillage in farmed fields. Manufacturer shall not be responsible for damage or injury resulting from any other use.

Grégoire-Besson machines are designed according to European Directive 2006/42/CE and have the CE logo. The certificate of conformity attests that machines comply with essentials health and safety requirements for users.

PRODUCT IDENTIFICATION

Please record here purchasing date, model and serial number of your equipment (refer to identification plate on hitch). Always refer to these information to get prompt and good service.

Purchasing date :

Model :

Serial number :

Salesman's phone :

2. SAFETY INSTRUCTIONS

2.1. SAFETY STICKERS



Reference : UI 1980

READ OPERATOR'S MANUAL

Read operator 's manual and safety instructions before starting the use of your equipment and follow them while using.



Reference : UI 1978

STAY IN A SAFE POSITION

Do not climb on the machine. Do not stand between machine and tractor.



Reference : UI 127

MOVE AWAY FROM THE MACHINE

Danger in the working area, stay clear from the machine.



Reference : UI 126

UNFOLDING AREA

Stay clear of equipment when folding or unfolding.



Reference : UI 131

SECURE THE MACHINE BEFORE ACTION

Always install all lockup devices to secure machine before any intervention on it.



Reference : UI 1979

MOVING PARTS

Always stay far away from parts in movement.



Reference : UI 128

HYDRAULIC LEAK AND MAINTENANCE

Caution, high pressure fluids can cause injury. Follow safe practices.



Reference : UI 1981

MACHINE UNFOLDING

Never stand under machine lateral sections. Always store machine unfolded.

Positioning safety stickers on the machine

When cleaning the machine, do not damage stickers.
Replace any damaged or missing sticker.

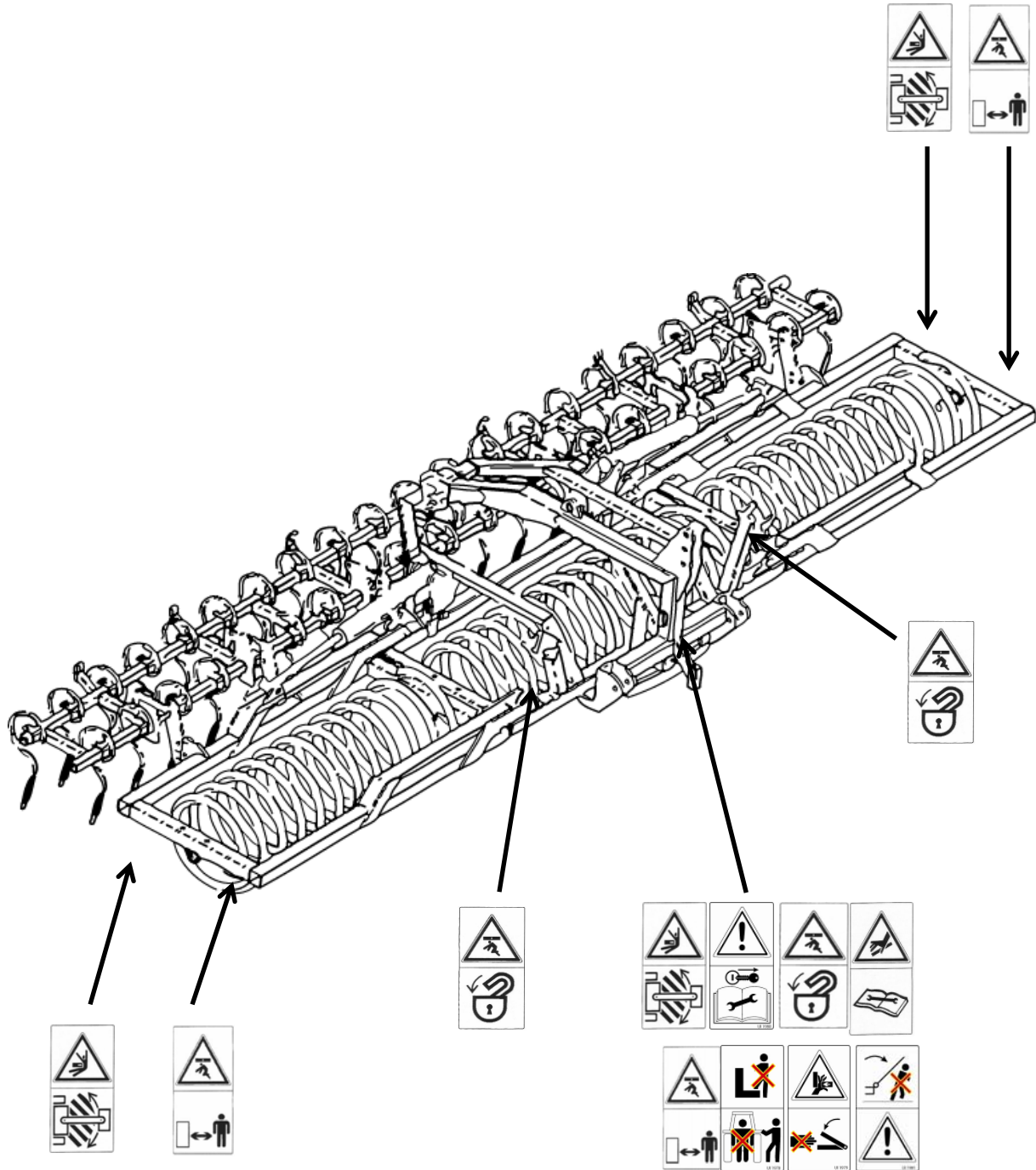

2.2. SAFETY WHILE ATTACHING AND DETACHING



- Do not let **anyone to stand between the machine and the tractor** when you back up to hitch.
- Before leaving the tractor to hitch or unhitch, set tractor parking brakes.
- Never attempt to attach the machine if pins, tractor hitching balls, tractor drawbar, or machine linkage are worn, cracked or not compatible.
- Completely lower the machine to the ground before unhitching. Make sure it is on a level and firm surface.
- Remove pressure from hydraulic lines before disconnecting them.
- Before leaving the machine for storage, make sure it is in a safe place and that there is no risk to damage whether anything or anyone.

2.3. SAFETY WHILE CONNECTING HYDRAULIC LINES



- Hydraulic circuit might be highly pressurised.
- **Never use your hands to locate a hydraulic leak.** Hydraulic fluids escaping under pressure have sufficient force to penetrate the skin, causing severe injury. In case of any injury, **see a doctor immediately.**
- For equipments loaded with several hydraulic connectors, **make logical and appropriated connections.**
- Before connecting hydraulic circuit, **make sure that there is no pressure on both sides (tractor and machine).**
- Regularly check hydraulic lines and connections. **Replace any damaged or leaking component** by an original part with the same specifications.
- Before any intervention on hydraulic circuit, **lower machine to the ground and release pressure moving control lever in the tractor's cab.**

2.4. SAFETY WHILE OPERATING MACHINE

- **Never attempt** any intervention on the machine while it is in motion.
- Do **not** allow anyone to **stand close to pivot points** : bottoms safety device (shearing bolt or non-stop), all pivoting linkage.
- Wear close **fitting clothing** and **appropriate safety devices** for the job you have to do (heavy leather gloves, safety shoes, earplugs, ...).
- Do not allow anyone to stand close to the machine.
- Do not attempt to do any adjustment if you have not perfectly understood its procedure.
- Always use tools or equipments appropriate to the job you are doing. All Grégoire-Besson equipments are metric standards.
- Learn how to operate your machine and how to use its controls. Do not let anyone operate without instruction.
- Do not extend turnbuckle adjusters too much to avoid any threads damaging or intempesive pulling out.
- Only one person (the operator) should be in the tractor's cab when it is in operation. **No one on the machine while working or travelling on the road.**
- When earring or feeling unusual vibrations, stop the machine. Find the problem and solve it before starting operating again.



If your machine is equipped with a hydraulic folding mechanism, **always use it from tractor's cab**, once you are sure that folding area is free from spectators or obstacles.

2.5. SAFETY FOR MAINTENANCE



- Maintenance area shall be **clean, dry, with enough light and ventilation**.
- For any intervention on the machine in raised position, **always securely support all components** before starting maintenance.
- **Maintenance operations on elements under pressure or under tension** (resorts, accumulators, ...) require specific procedure and equipments. **Only qualified persons shall perform them in appropriate conditions**.
- After servicing remove all tools, components and parts you used.
- Regularly **check tightness of wheel studs, wearing parts bolts, and all other bolts and nuts**.
- **Always use genuine parts corresponding to manufacturer's technical specification requirements**.

2.6. SAFETY FOR ON HIGHWAY TRANSPORT



FOR YOUR OWN SAFETY AND THE ONE OF THE OTHER, RESPECT THE FOLLOWING RULES :

- All Grégoire-Besson equipments shall be used **complying with area's current rules and laws** concerning **safety instructions, accident prevention and provision of Highway Code**.
- Before road transport, always **check for wheels studs** and wheels mounting brackets carriage bolts **tightness** ; **check tyres general state and pressure** : do not drive with low pressure, cuts or damaged tyres or rims.
- **Use all devices required by your area's current laws** (lights, reflectors, signs, ...). They might be removed during field operation to prevent from any damage. It is the operator's responsibility to comply with current law and to follow its evolutions.
- Regularly check hitching pins, change them if necessary. Tractor's ball joint may also wear, do not hesitate to replace them with new ones having at least Waltersheid fabrication quality.
- Drive **at reasonable speed** complying with local laws **to always keep control** of tractor and equipment. Pay special attention on irregular or rough roads. **Do not attempt to drive down a hill faster than it could be possible to drive it up**.
- Tractor used for road transport shall have the same power rating and weight as the one used for field operations.
- **Never attempt any manoeuvre if area is not free from spectators**.
- If your machine is equipped with a **folding mechanism** (manual or hydraulic), **use it making sure folding area is free from spectators** and obstacles.
- Follow all **safe driving practices** when travelling, moreover **on corners, rough or narrow roads**.
- When **leaving tractor** even for a short period, **shut off engine, remove ignition key and set parking brakes**.
- Forbid anyone to stand between tractor and machine or on the machine travelling on the road.

3. MACHINE DESCRIPTION

3.1. IDENTIFICATION VIEWS

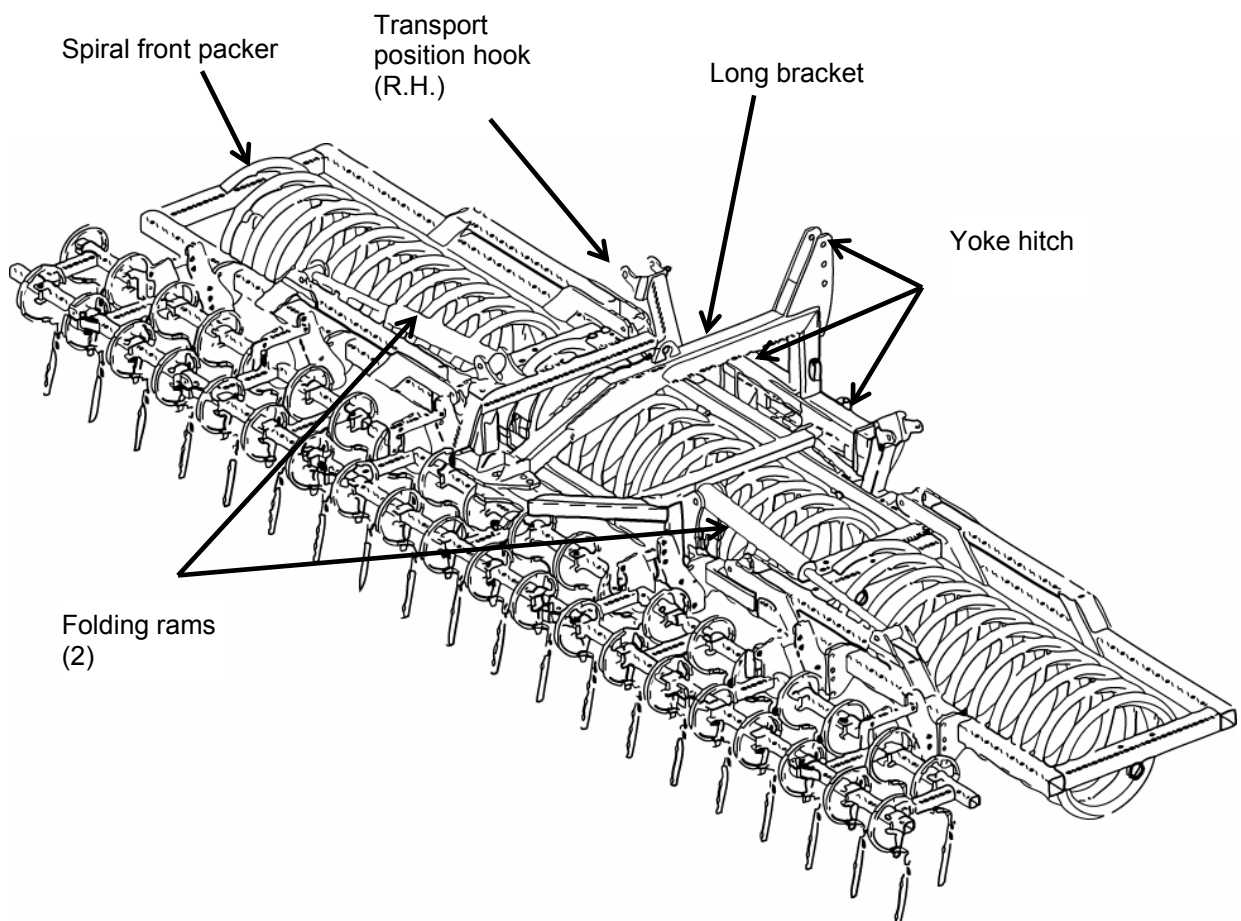
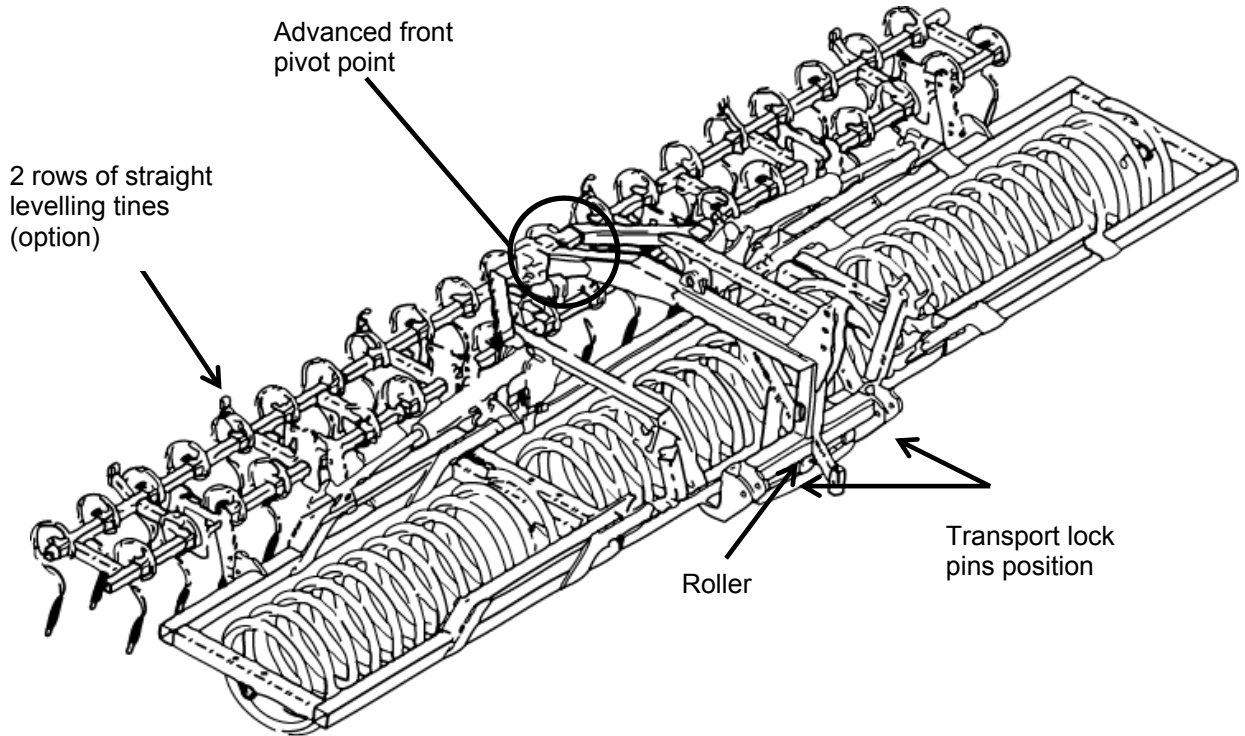

3.2. TECHNICAL SPECIFICATIONS

Part	Equipment
Front hitch	<ul style="list-style-type: none"> In yoke Ø II, width II
Frame	<ul style="list-style-type: none"> Self-steer, pulled by the front Fixed or foldable (2.60 m - 3 parts) Model 4.00 m vertical fold (90°) - 1 ram Models 5.00 m and 6.00 m over centre fold - 2 rams - mechanical locking device
Spiral packer	<ul style="list-style-type: none"> 40 mm square section, Ø 580 mm Central axle 60 mm Bearings diameter 50 mm
Optional equipment	<ul style="list-style-type: none"> Two rows of levelling tines Tines 32 x 12 or 45 x 12

Grégoire-Besson authorized dealers know area and working conditions. They may give information according to technical choices and latest equipments evolutions. Grégoire-Besson is also represented on farm equipment shows.

3.3. DIMENSIONS AND WEIGHTS

Working width	Transport width	Indicative weight. (without 2 rows of tines)	Indicative weight / 2 rows of tines
1.50 m (fixed)	1.50 m	500 kg	700 kg
3.00 m (fixed)	3.00 m	850 kg	1 150 kg
3.50 m (fixed)	3.50 m	900 kg	1 250 kg
4.00 m (fixed)	4.00 m	1 000 kg	1 400 kg
4.00 m (foldable)	2,60 m	1 250 kg	1 650 kg
5.00 m (foldable)	2.60 m	1 350 kg	1 800 kg
6,00 m (foldable)	2.60 m	1 600 kg	2 100 kg

Dimensions and weights are indicative and subject to variations according to equipments and options.

Note : after use, ground or residue accumulations may increase machine's weight.

3.4. SIGNS

Light and signs kits are available for all Grégoire-Besson equipments. Contact an authorized dealer.

Note: it is the operator's responsibility to comply with local current applicable law before any transport on public road.

3.5. TRIANGULATION

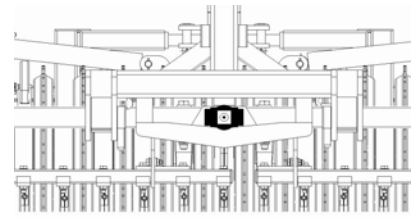
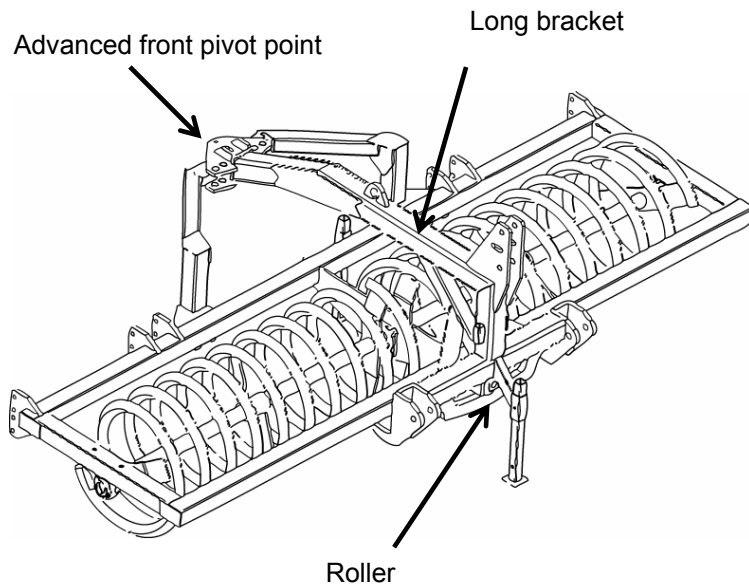

Position of roller machine raised up

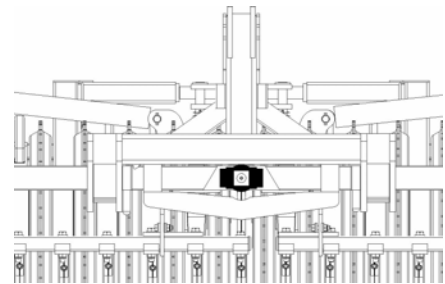

Position of roller machine lowered

All machines from Plani-serie range are built around the same triangulation :

- three point hitch on roller,
- long bracket,
- advanced pivot point.

This configuration provides several advantages to the machine :

- stability : machines are pulled by the front and not pushed by behind,
- manoeuvrability : machines are self-steer,
- efficiency : sharp and easy steering even in slopping fields,
- automatic re-alignment when raising up the machine.

3.6. TWO ROWS OF STRAIGHT TINES (option)

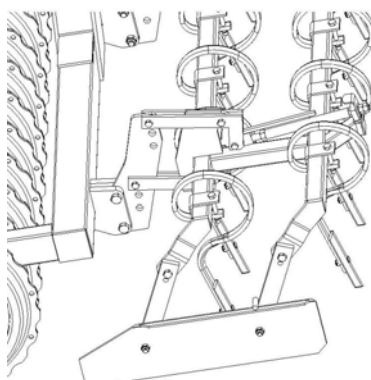

All machines from Plani-serie range may be equipped with two rows of levelling straight tines.

Using these optional tines provides flat surface for the machine. Tines shall not work the ground in deep.

Two types of tines are available :

- straight tines 32 x 12
- straight tines 45 x 12

Note : all machines from Plani-serie range are predisposed to receive this option. It is then possible to add two rows of levelling straight tines on an already delivered machine.

4. PREPARING THE TRACTOR

Follow recommendations given in the safety section of this manual. They are not restrictive.

4.1. REQUIRED HYDRAULIC FRONT LIFT CAPACITY

Data given hereafter are indicative only. For any further information, contact an authorized Grégoire-Besson dealer.

Working width	Indicative required front lift capacity
1.50 m	1.0 t
3.00 m	1.5 t
3.45 m	1.5 t
4.00 m	2.0 t
5.00 m	2.5 t
6.00 m	2.5 t

4.2. TRACTOR WHEELS

4.2.1. Tractor tyres

Check tractor tyres general state and pressure. Pressure should be the same on both sides of the tractor for a nice drivability in the field and on the road.



IMPORTANT : inflate tyres following manufacturer's recommendations.

4.2.2. Distance between tractor tyres

Generally, using a large tillage equipment, the wider is the distance between tyres, the better is the drivability.

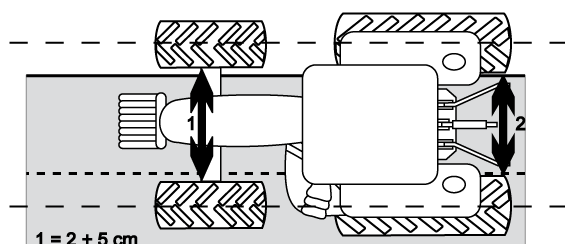

To be able to steer the tractor, the middle of the front axle shall be lined up with the middle of the rear axle.

In sloping fields, a large distance will provide good stability.

4.3. TRACTOR EQUILIBRIUM

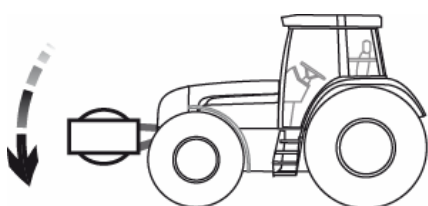

For an optimal behaviour of tractor + front implement both on the road and in the field, weight balance on tractor must be respected. A rear implement at least as heavy as front implement should be attached.



IMPORTANT : follow recommendations given in tractor operator's manual. For any further information, contact an authorized dealer.

5. ATTACHING AND DETACHING

Follow recommendations given in the safety section of this manual. They are not restrictive.

IMPORTANT : always make sure that hitching never leads to :

- overload : respect maximum admissible hitch load,
- unbalance: load tractor front end if necessary. Refer to point 4.3.

5.1. ATTACHING MACHINE TO TRACTOR

5.1.1. Hitching lower links

- Remove safety bolts and hitch pins.
- Remove balls from tractor lift link automatic hooks.
- Check for diameter and length compatibility between hitch pins and balls.
- Install balls on pins through lower machine hitching holes. Secure with safety bolts.
- Slowly drive ahead till automatic hooks are lined up underneath hitch balls.
- Raise tractor front hitch to lock automatic hooks and till machine is about 5 cm above ground surface.
- Check for automatic hooks latch handles good locking.
- Hitch top link.



IMPORTANT : make sure to have enough clearance between machine yoke hitch and tractor lower lift links to avoid any possibility of contact from working to raised position. A second verification shall be done once machine is in the field in truth working conditions.

5.1.2. Hitching top link

- Once tractor lift links are correctly hooked up, check top link general state and compatibility with tie rod.
- Attach top link in one of the three available holes.
- Raise machine to the maximum and make sure there are no interference with tractor.
- Final top link adjustments (length and position) will be made in the field.
- Do not forget to install safety clip back.
- Put parking stand (s) in working position.



IMPORTANT : make sure to have enough clearance between machine yoke hitch and top link to avoid any contact from working to raised position. A second verification shall be done once machine is in the field in truth working conditions.

Connect hydraulic lines.

5.2. DETACHING THE MACHINE

Before detaching, make sure that ground is flat and firm enough to support the machine. Use safety blocks to support machine components and / or parking stand if necessary.



DANGER : do not let any part of your body underneath the machine when lowering it to the ground.

Crushing may lead to death.

Proceed in the logical attaching opposite way :

- 1) Put machine in working position = it shall stay on its tines,
- 2) Put stand(s) in parking position,
- 3) Completely lower the machine to the ground,
- 4) Detach top link,
- 5) Remove pressure and disconnect hydraulic lines,
- 6) Detach top link and lower lift links.

Always operate with care.

6. HYDRAULIC CONNEXIONS

Follow recommendations given in the safety section of this manual. They are not restrictive.

6.1. REQUIRED HYDRAULIC REMOTES

- 1 DA remote for hydraulic **folding** (according to model)

6.2. HYDRAULIC CONNECTIONS

- Always wipe hydraulic couplers with a clean rag on both tractor and machine sides before connecting circuits.
 - Always check for machine hydraulic connectors and tractor remotes compatibility.
 - Logically connect hydraulic lines for the user :
- ⇒ Put most frequently used functions on closest lever
- ⇒ Watch for the way hydraulic flow is delivered : pull the lever to put machine in transport position (raise up / fold), push it to put machine in working position (lower / unfold).
- ⇒ Identify hoses using colour collars and signs (+ to extend rods, - to retract them).
- Check for hydraulic hoses length : too short they may break during sharp turns, too long they may interfere with tractor lift arms or tyres.

In case of any problem, do not hesitate to contact an authorized Grégoire-Besson dealer.

7. PREPARING THE MACHINE

Follow recommendations given in the safety section of this manual. They are not restrictive.

7.1. ADJUSTING POINTS LOCALIZATION

Find adjusting points and check their lubrication and work. Doing this checking task close from a machine shop is better than doing it in the field.

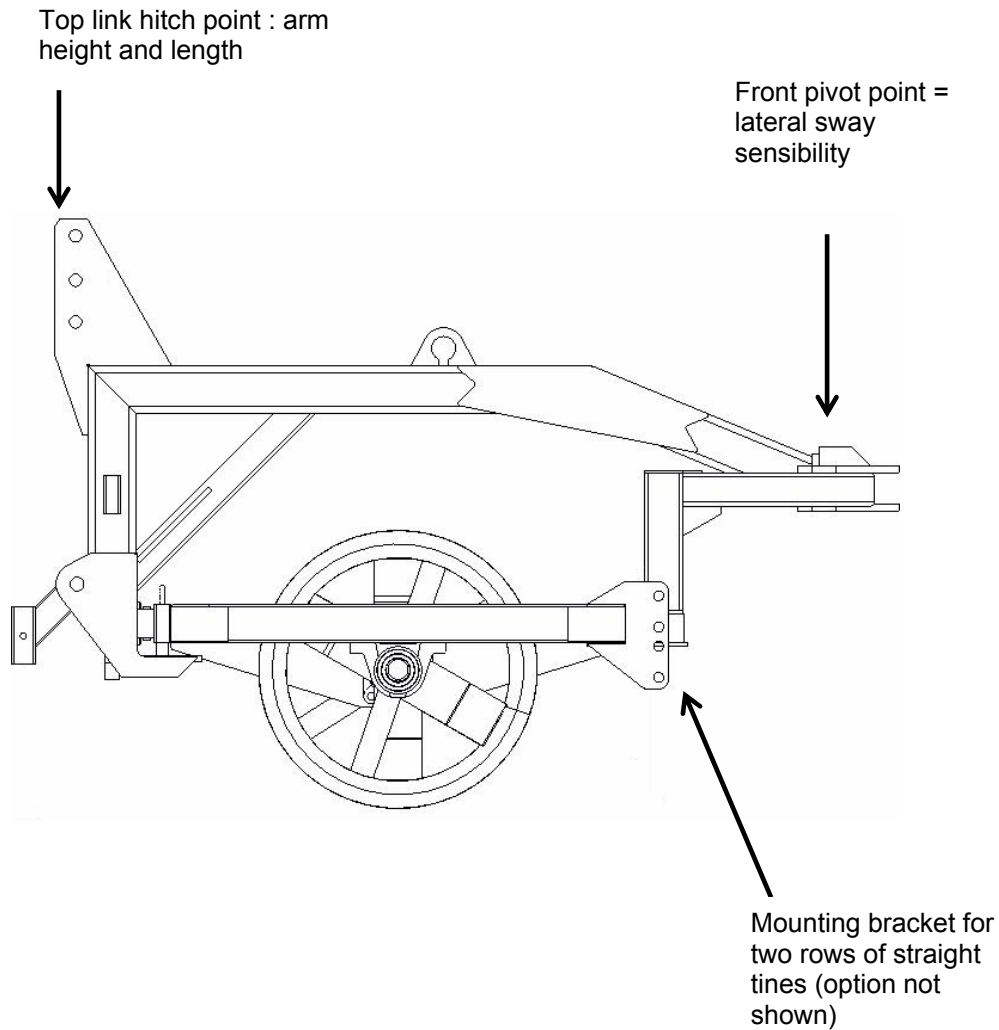

7.2. ADVANCED FRONT PIVOT POINT

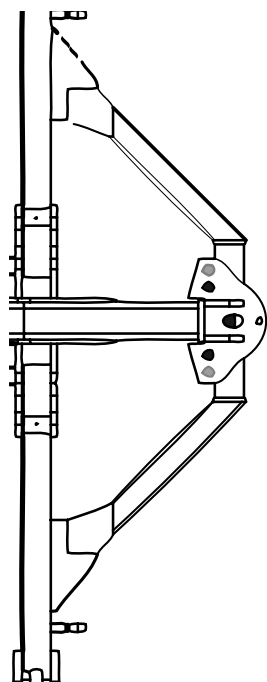

All machines from Plani-serie range have an advanced front pivot point located by the end of the long bracket.

Adjustment procedure

At the manufacture, pins are set centre = black colour holes in the picture.

If machine is difficult to drive and / or missing stability, put pins in outside position = grey colour on the picture. This will reduce lateral sway.

Note : both rear pins shall be positioned the same regarding front pin = both in black colour holes or both in grey colour holes.

7.3. LEVELLING TINES HEIGHT ADJUSTMENT (option)

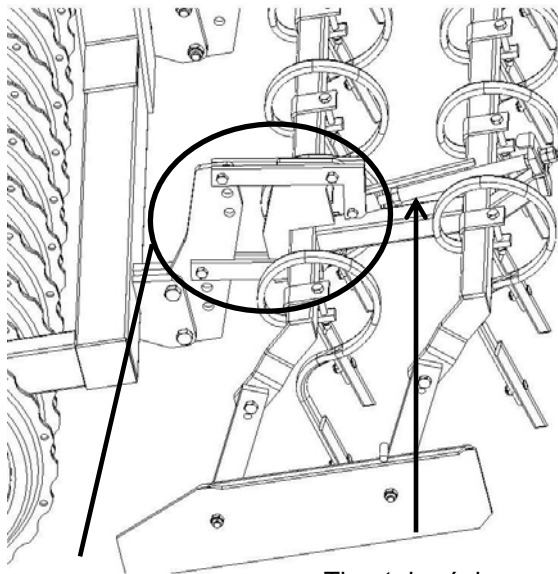

Parallélogramme

Tirant de réglage

This section concerns machines equipped with two rows of tines only.

The two rows of tines are an accessory for levelling before implement and tractor. They shall not work the ground in deep.

Each section is set on the machine through two parallelograms with turnbuckles for adjustment.

Adjustment procedure

- Machine shall be in working position and raised up,
 - Take adjuster on central frame,
 - On each turnbuckle :
 - remove safety lock
 - turn clockwise to raise tines
 - turn counter clock wise to lower tines
 - put safety lock back in
 - **All turnbuckles shall be adjusted the same** for machine to work evenly,
- Put adjuster back on central frame,
 - Lower the machine to the ground and work on a few meters. Check adjustment performance. Start again if necessary.

Note : tines shall not work deeper than half of point height.

8. TRANSPORTING

Follow recommendations given in the safety section of this manual. They are not restrictive.

8.1. CHANGING TO TRANSPORT POSITION

Before driving on a public road with the machine, put it in transport position :

- **Raise machine to the maximum.**
- **Fold lateral wings** (foldable models only).
- **Install the two transport lock pins on lateral frames** (models 5.00 and 6.00 m only)
- **Install the two transport lock pins on headstock** to prevent any lateral movement (refer to picture hereafter).
- Lower the machine to lower gravity centre and improve visibility if necessary. Do not lower too much to avoid any contact with the ground.
- **In the cab lock all control levers** (hydraulic remotes, hitch, ...), to prevent any unforeseen movement and potential accident.
- **Install all lights, reflectors and signs required by current applicable law.**

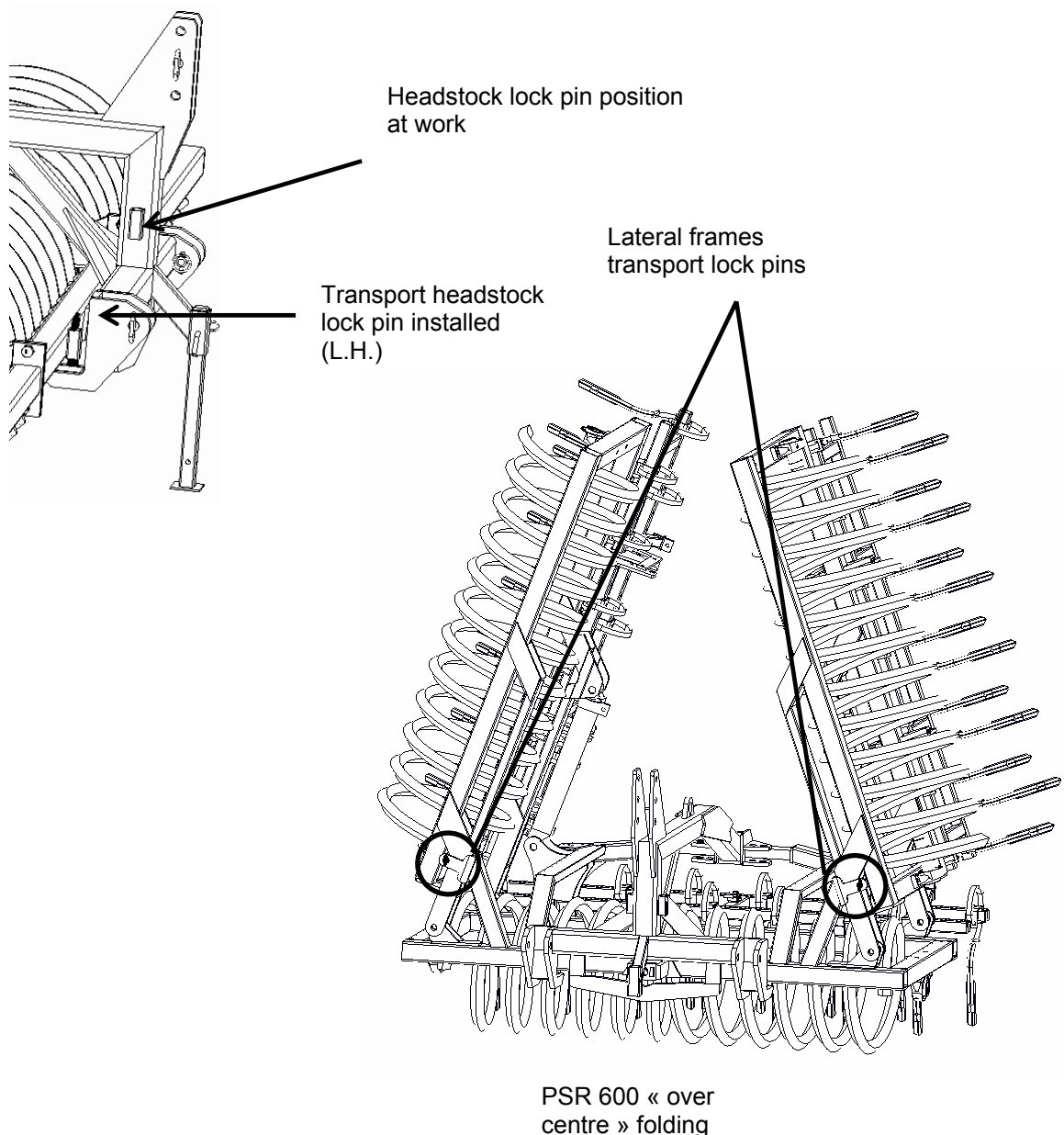

8.2. CHANGING TO WORKING POSITION

Follow here above described procedure in the opposite way.
Once machine is unfolded, put hydraulic control lever on float position.
Remove lights and signalisation kits if necessary.

- **Remove the two transport lock pins on headstock** to allow lateral movement (refer to picture here above).
- **PSP 500 & PSR 600** when unfolding, check for machine proper working position locking.

8.3. DRIVING ON PUBLIC ROAD

Before driving on a public road :

- **Be sure all signs, reflectors and lights required by local current law are in place, clean and visible to traffic.**
- Make sure there are no interferences between tractor and machine.
- Adopt a gentle attitude towards other public road users.

On public road, comply with local applicable laws :

- Tractor required for road transport shall equal the size and the horse power rating of the tractor used to work in the field.
- Do not drive over 25 km/h (= 15 mph).
- Drive at a reasonable speed to maintain complete control of both tractor and machine.
- Reduce speed on corners and on rough grounds.
- Do not drive down a hill faster than it could be possible to drive it up.
- Do not apply the tractor brakes to attempt a sharp turn.
- Always check wheel studs tightness before driving on a public road. They may get loose because of vibrations.
- Respect authorized maximum size for transport load (width, weight, length). For over sized loads, comply with current law taking all necessary precautions (signs, lights, escort, authorizations, ...).
- Respect the maximum wheel axle load and the maximum total driving load. Make sure front axle carries at least 20% of tractor's tare. Use front end weights if necessary.

ATTENTION : driving on public roads, operator is responsible for both tractor and equipment. He has to comply with current applicable law (getting in conformity with it and following its evolutions).

9. FIELD ADJSUTMENT

Follow recommendations given in the safety section of this manual. They are not restrictive.

9.1. FIELD UTILIZATION

Put machine in working position (refer to previous section).

Machine has been designed to accept various speed operation. Then rear implement will determine speed operation.

Always lift up machine before manoeuvring on headlands.

Never attempt a sharp turn with the machine in working position.

Slow down before manoeuvring or crossing any obstacle (ditch, ridge, rocky spot, ...).

IMPORTANT : before beginning field utilization, entirely read this chapter to understand all adjustments, their order and procedure.

IMPORTANT : always do one adjustment at a time. Then it is easier to check its performance and to change it if necessary.

9.2. DEPTH CONTROL AND FRONT TO REAR LEVELLING

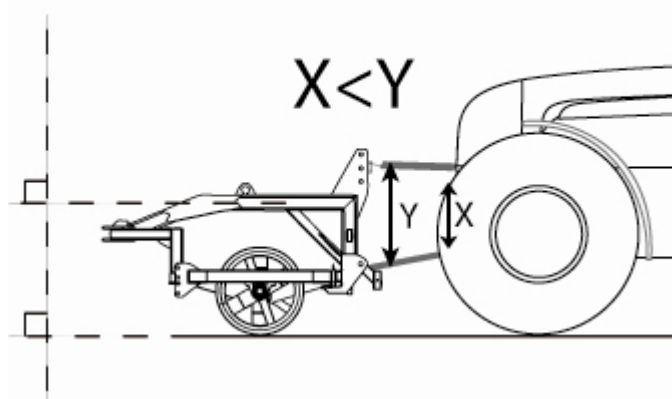

- **Lower the machine to the ground** and put hydraulic **control lever on float position** = neutral position. Machine shall be let free on the ground = neither pushed nor retained.
- **Top link** shall be positioned **slightly higher on machine side** than on tractor side.
- **Top link length** shall be set **so that machine frame is levelled** front to rear in working position.
- **Set the height of the two rows of levelling tines** if machine is equipped with.

9.3. SIDE TO SIDE LEVELLING

In working position, machine main frame shall run levelled from side to side. This is what happens generally when :

- tractor has been properly prepared : tyre pressure the same on both sides, front hitch levelled,
- machine equipments (two rows of levelling tines) all set the same.

Note : once machine is in the ground at desired depth, back up a few meters to check its levelling.

9.4. IF GROUND IS NOT LEVELLED

If machine does not leave a perfectly levelled surface, check the following adjustments and modify them if necessary :

- front to rear levelling : top link length
- side to side levelling : tractor hitch levelling
- two rows of levelling tines height. This option may be required if machine is not equipped.

10. MAINTENANCE

Follow recommendations given in the safety section of this manual. They are not restrictive.

10.1. GENERAL INSTRUCTIONS



Operator and owner are responsible for good machine maintenance.



Inspect machine before and after each use. Repairs and service have to be done immediately so that they are not forgotten. Always leave the machine in a good state.

Cleaning the machine facilitates inspection. Check general state of machine, weldings, wheels studs, tyres, ...

Be careful with hydraulic lines : frictions may lead to excessive wearing and lines may leak. Never search a leak with your hands. Immediately replace any defective component. Spare components shall have the same characteristics.

Parts working in the ground may be sharpened and cause severe injury. Take particular care and use heavy leather gloves to remove them.

Never attempt any intervention on the machine while tractor engine is running.

Always properly secure all components before starting any maintenance operation underneath the machine.

Before using the machine for the first time, check all bolts tightness. Verify after 50 working hours and then at the beginning of each season. Pay special daily attention on wearing parts bolts and nuts tightness in rocky or dry conditions (lots of vibrations).

Wrong waste management is a danger for environment : collect waste oil, paint removers, accumulators, worn tyres ... Bring them back to a distributor or to an authorized collector. Do not let them in the nature.

10.2. LUBRICATION

A good lubrication of all moving parts will both allow the machine to work fine and insure its long-lasting.

Grease fittings are installed on all pivot points. Grease both lubricates moving parts and chases away abrasive dust or water that could come into pivot points.

Use quality grease, type Unil – Opal MS02 or equivalent.

Always wipe grease fittings with a clean rag before introducing grease. Do not hesitate to change any worn or broken grease fitting. Check for good grease course.

Remove all grease accumulation around grease fittings or moving parts.

Refer to grease fittings placement and frequency on the following drawing. Hard or intense conditions would require more.

The best is to grease regularly with regular quantity. Do not over grease.

Grease fitting placement	Frequency
Lateral wing pivot point	50 h
Folding cylinder (1 grease fitting on each end)	50 h
Bearing (1 grease fitting on each)	50 h
Roller	50 h

10.3. SPARE PARTS

Genuine Grégoire-Besson parts have been specially designed and developed. Only the use of these parts will ensure proper fit, longevity and field quality work of the machine.



Using any other spare part than certified from Grégoire-Besson will void warranty.

Changing wearing parts too late may be source of poor quality work (penetration troubles, poor mixing ...) and may damage structure parts.

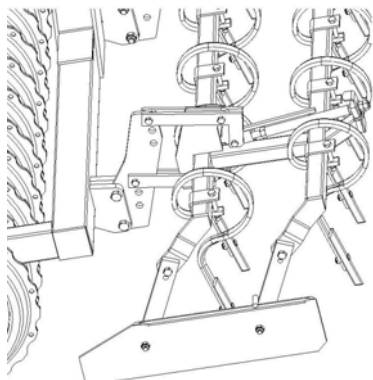

Tine 32 x 12 complete	DBDT3212
Tine 32 x 12 clamp	DPBR1112
Screw H M12x90	BV129001
Lock nut M12	VJ322
Straight point 215 x 38 x 6	FOMA0017
Bolt 10x38 TOCC	BB103800
Tine 45 x 12 complete	M300031 (ex. 7C00068)
Tine 45 x 12 clamp	7C00050
Screw H M12x90	BV129001
Lock nut M12	VJ322
Straight point 230 x 40 x 6	7C00131
Bolt 10x38 TOCC	BB103800

10.4. STORAGE SAFETY

- Before detaching the machine for storage, make sure ground is clean, flat and firm enough.
- Use parking stand and all other locking devices to prevent from any unforeseen movement during detachment or later on.
- Always store machine in working position (= unfolded).
- Block machine wheels to avoid any unforeseen movement.
- During storage, wheels shall not carry any weight.
- NEVER detach machine in raised position.
- Remove pressure from hydraulic circuit (engine shut off, shake hydraulic control lever in the cab).
- Store machine away from human activity.
- Store machine in a dry and dust free area (shed). Protect ram rods that cannot be retracted from rust using grease or oil.

CAUTION : never let children play around farm equipment.

11. WEIGHT DISTRIBUTION

1. RESPECT WEIGHT DISTRIBUTION

Before hitching fully mounted equipments a tractor (front hitch and / or rear hitch), check the following points :

- do not exceed tractor maximum authorized weight,
- do not exceed maximum authorized weight on hitching points
- do not exceed maximum authorized weight on wheel axles
- do not exceed maximum authorized weight on tyres
- weight on front axle shall be at least 20 of unladen weight of the tractor

2. REQUIRED DATAS

Indicator	Data	How to find it ?
PV	Tractor unladen weight (kg)	Instructions manual or registration documents
	Tractor maximum authorized weight (kg)	Instructions manual or registration documents
	Maximum authorized weight on tractor front axle (kg)	Instructions manual or registration documents
P1	Tractor unladen weight on front axle (kg)	Instructions manual or registration documents
P1 _{cal}	Tractor real weight on front axle (kg)	Calculation
	Maximum authorized weight on tractor rear axle (kg)	Instructions manual or registration documents
P2	Tractor unladen weight on rear axle (kg)	Instructions manual or registration documents
P2 _{cal}	Tractor real weight on rear axle (kg)	Calculation
M1	Total front end weight or front implement weight (kg)	Front end specifications or front implement instructions manual
M2	Total rear implement weight (kg)	Implement instructions manual
a	Distance between front end weight (or implement) centre of gravity and the middle of front axle (m)	Instructions manuals or measurement
b	Distance between the middle of front and rear axles (m)	Instructions manual or registration documents
c	Distance between the middle of rear axle and rear hitching points (m)	Instructions manual or measurement
d	Distance between rear hitching points and rear implement centre of gravity (m)	Implement instructions manual

3. CALCULATIONS

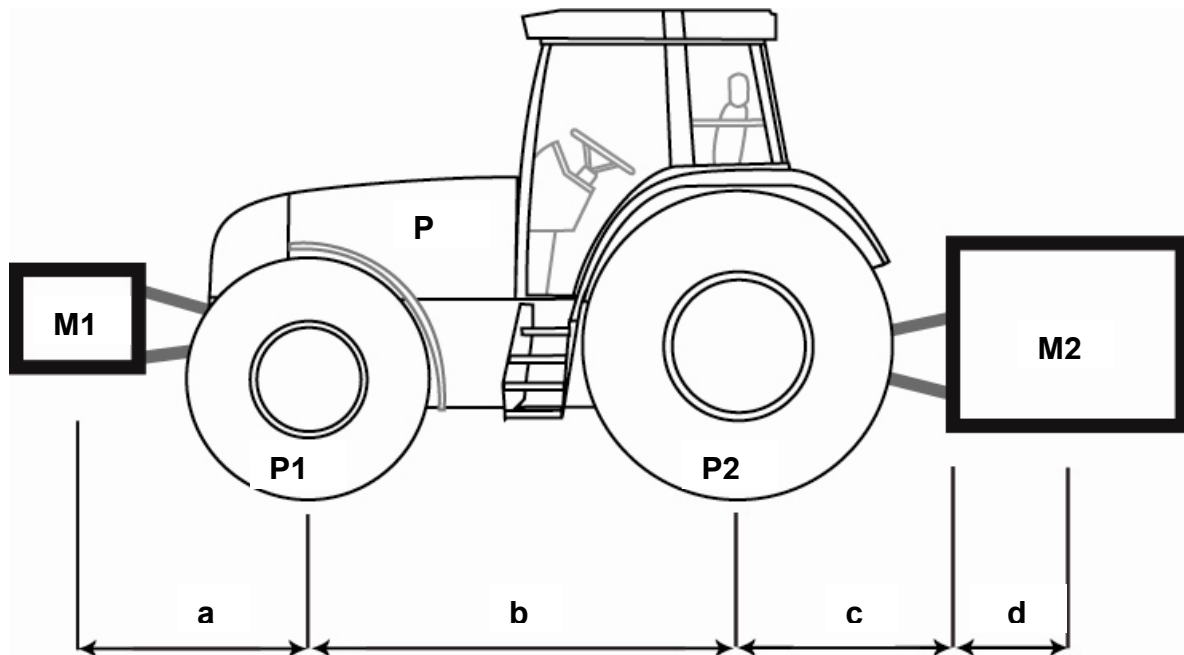

3.1. Minimum front end weighting calculation

$$M1_{\text{mini}} = \frac{M2x(c+d) - P1xb + 0.2xPxb}{a + b}$$

3.2. Minimum rear end weighting calculation

$$M2_{\text{mini}} = \frac{M1xa - P2xb + 0.45xPxb}{b + c + d}$$

3.3. Real over all weight calculation

$$PT_{\text{real}} = PV + M1 + M2$$

3.4. Real front axle weight calculation

$$P1_{\text{cal}} = \frac{M1x(a+b) + P1xb - M2x(c+d)}{b}$$

3.5. Real rear axle weight calculation

$$P2_{\text{cal}} = PT_{\text{real}} - P1_{\text{cal}}$$

NOTES

12. QUICKLY STARTING - PLANISPIRE

Take all precautionary measures. Respect safety recommendations.

PREPARING THE TRACTOR

- 1. Check tyre pressure**
It should be the same on both sides on each axle.
Always follow tyre manufacturer recommendations.
- 2. Adjust tractor hitch levelling**
Tractor hitch shall be perfectly levelled.
Arms shall be long enough so that working at desired depth there is still 30 mm chrome visible on lift ram.

HITCHING

- 3. Attach lower link arms**
- 4. Attach lower top link**
- 5. Make sure there are no interferences between machine and tractor from raised position to working position**
Machine shall never come in contact with tractor.
There should be no contact between tractor lift links and machine yoke hitch.
- 6. Connect hydraulic lines**
- 7. Transport / working positions**

Transport position	machine raised up with enough visibility, headstock locked, lateral wings folded (according to models)
Working position	headstock released, lateral wings unfolded (according to models)

FIELD ADJUSTMENT

- 8. Lower the machine and put hydraulic control lever on float position**
Machine shall work by its own weight, it shall not be pushed or retained
- 9. At desired speed and depth, machine shall run level**

Side to side levelling	tractor hitch levelling
Front to rear levelling	top link attached slightly higher on tractor side top link length set so that machine frame runs levelled
- 10. Accessories adjustment**
Set tines height using adjuster and turnbuckles.

MAINTENANCE

- 11. Follow recommendations given in this manual according to lubrication and maintenance of the machine**

GRÉGOIRE  **BESSON**

**49230 MONTFAUCON-MONTIGNÉ-SUR-MOINE
FRANCE**

TÉL. (+33) (0)2 41 64 72 67

FAX (+33) (0)2 41 64 67 73

GRÉGOIRE-BESSON UK

Bourne Road, Carlby - STAMFORD LINCS PE9 4 NG – ENGLAND
phone (44) 01 778 590 223 - Fax (44) 01 778 590 645

GRÉGOIRE-BESSON CANADA INC

4480, Rue Martineau - ST-HYACINTHE (P. Québec) - CANADA J2R 1V1
TÉL. (1) 450 799 56 15 - FAX (1) 450 799 56 29

GRÉGOIRE-BESSON POLSKA

Ul. Obornicka 1a - PL - 64 600 OBORNIKI - Polska
TEL/FAX : (061) 29 77 530
gbesson@poczta.onet.pl
Ruda 12 - PL - 64610 ROGOZNO – TÉL / FAX (48) (67) 261 97 79

ООО «ГРЕГУАР-БЕССОН ВОСТОК»

Россия 308018 г. Белгород,
ул. Корочанская, 132а
Тел/факс: +7(4722) 58 70 36, 58 70 35
E-mail: info@gbvostok.ru

法国格力格尔 - 贝松公司北京代表处
北京市朝阳区延静里中街3号长信大厦220室
邮编：100025

WEB : www.gregoire-besson.fr **E.MAIL** : Contactfr@gregoirebesson.fr